



# Watershed-Based Natural Resource Management for Drought Proofing



B KRISHNA RAO | K N RAVI | K KRISHNA REDDY | M MADHU  
M PRABHAVATHI | B S NAIK



# **Watershed-Based Natural Resource Management for Drought Proofing**

## **Editors**

**B Krishna Rao**

**K N Ravi**

**K Krishna Reddy**

**M Madhu**

**M Prabhavathi**

**Bhupendra Singh Naik**



**ICAR-Indian Institute of Soil and Water Conservation (IISWC)  
Research Centre, Ballari -583 104 (Karnataka)**

**&**

**National Institute for Agricultural Extension Management (MANAGE),  
Hyderabad, Telangana**



# Watershed-Based Natural Resource Management for Drought Proofing

**Editors:** Rao, B. K., Ravi, K. N., Krishna Reddy, K., Madhu, M., Prabhavathi, M. and Naik, B. S.

**Edition:** 2024. All rights reserved.

**ISBN :** 978-81-19663-55-2

**Copyright:** ICAR-Indian Institute of Soil and Water Conservation, Research Centre, Ballari (Karnataka) & National Institute for Agricultural Extension Management (MANAGE), Hyderabad, Telangana

**Citation:** Rao, B. K., Ravi, K. N., Krishna Reddy, K., Madhu, M., Prabhavathi, M and Naik, B. S. (2024). Watershed-based Natural Resource Management for Drought Proofing [e-book]. ICAR-Indian Institute of Soil and Water Conservation, Ballari and National Institute for Agricultural Extension Management (MANAGE), Hyderabad, pp. 174.

This e-book is a compilation of resource text obtained from various subject experts on “Watershed-based Natural Resource Management for Drought Proofing”. This e-book is designed for researchers, academicians, extension workers, research scholars and students engaged in agricultural water management and watershed management. Neither the publisher nor the contributors, authors and editors assume any liability for any damage or injury to persons or property from any use of methods, instructions, or ideas contained in the e-book. No part of this publication may be reproduced or transmitted without prior permission of the publisher/editor/authors. Publisher and editor do not give warranty for any error or omissions regarding the materials in this e-book.

Published for Dr. Yogita Rana, I.A.S. Director General, National Institute of Agricultural Extension Management (MANAGE), Hyderabad, India and Dr. M Madhu, Director, ICAR-Indian Institute of Soil and Water Conservation, Dehradun, Uttarakhand, India.

## Preface

A significant portion of Indian agriculture, approximately 52% of the country's net sown area, is rainfed and contributes nearly 40% of total food production. However, the unpredictable and often insufficient rainfall, coupled with adverse climatic conditions, makes rainfed agriculture highly complex and risky. Common challenges in these areas include soil erosion, land degradation, water scarcity, low crop yields, drought, poverty, and food insecurity.

With the growing population and increasing food demand, there is an urgent need to enhance the productivity of rainfed areas while simultaneously conserving and managing natural resources. When managed properly, these areas hold immense potential to significantly contribute to food production and support faster agricultural growth. In this context, watershed-based natural resource management is a powerful tool for addressing the challenges faced in rainfed regions. It offers multiple benefits such as controlling land degradation, improving climate resilience, increasing crop yields, and drought proofing, generating employment, enhancing livelihoods, protecting the environment, and improving the socio-economic status of local communities.

This edited book, *Watershed-Based Natural Resource Management for Drought Proofing*, is a valuable collection of materials drawn from fourteen lecture notes by various experts on soil and water conservation, drought proofing, and watershed management. The information presented here will be highly beneficial for field practitioners, researchers, and all those involved in watershed management programs by addressing long-standing needs and providing updated knowledge.

We are deeply grateful to Dr. M. Madhu, Director of ICAR-Indian Institute of Soil and Water Conservation, Dehradun, Dr. Yogita Rana, IAS, Director General of the National Institute of Agricultural Extension Management (MANAGE), Dr. P. Chandra Shekara, Former Director General, MANAGE, Hyderabad, India and Dr. Krishna Reddy K., Director (ICT) of MANAGE, for their invaluable guidance and support in the creation of this publication.

We welcome and appreciate suggestions for future improvements and guidance to enhance this publication.

**Editors**



**Dr. M. Madhu, Director  
ICAR-IISWC, Dehradun**

01.10.2024

## Foreword

In an agrarian society, monsoon plays a vital role for agriculture as well as society, deficit of monsoon causes the condition of drought and in India this is an annual crisis. The implications of drought go beyond water resources and affect drastically the society, its living conditions and environment as well. Generally, drought is viewed as lack of natural precipitation, infact, drought is an abnormal shortage of water and the problems of drought management are actually challenges of water resource regulation. From the perspective of managing drought as such, a holistic and interdisciplinary approach is the need of the hour for mitigating these ill effects. Of late, there is increased understanding among the decision-makers about the necessity to adopt a proactive approach in drought management. However, the fact remains that the watershed development is the most widely adopted technology for drought management around the world due to its suitability across climatic conditions. Watershed development offers a comprehensive solution with the potential to significantly improve water resources, replenish groundwater levels, and enhance natural ecosystems.

I am pleased to note that, ICAR-IISWC, Research Centre, Ballari and MANAGE, Hyderabad, Telangana is organizing a collaborative training programme on "*Watershed-Based Natural Resource Management for Drought Proofing*", the theme of the training is aligned closely with the global imperative of harmonizing human activities with sustainable natural resource management, as outlined in the WDC-PMKSY 2.0 programme and recent advances in watershed planning and implementation.

I hope this training provides an excellent platform for extension field functionaries, professionals, and other stakeholders to build core competencies, foster innovation, and stay updated with advances in watershed management. The e-book is a part of publication outcome from several lectures imparted in the training with key areas of watershed components such as the planning and design of water-harvesting farm ponds, groundwater recharge techniques, soil and water conservation treatments for both arable and non-arable lands, hydrology planning and monitoring, green cover enhancement techniques, drought assessment and management, indigenous technical knowledge (ITKs) on soil and water conservation, livelihood interventions and participatory rural appraisal (PRA) tools and techniques.

The document covers a wide range of topics on "Watershed-Based Natural Resource Management for Drought Proofing", I am confident that it will serve as a valuable resource for teachers, researchers, and extension personnel involved in watershed development and implementation. I congratulate the team of editors for their dedicated efforts in compiling this voluminous publication.

A handwritten signature in blue ink, appearing to read 'M. Madhu', written over a horizontal line.

**(M Madhu)**



**Dr. Yogita Rana, IAS**  
**Director General (MANAGE)**

01.10.2024

### Message

National Institute of Agricultural Extension Management (MANAGE), Hyderabad is an autonomous organization under the Ministry of Agriculture & Farmers Welfare, Government of India. The policies of liberalization and globalization of the economy and the level of agricultural technology becoming more sophisticated and complex, calls for major initiatives towards reorientation and modernization of the agricultural extension system. Effective ways of managing the extension system needed to be evolved and extension organizations enabled to transform the existing setup through professional guidance and training of critical manpower. MANAGE is taking responsible steps to this imperative need. Agricultural extension to be effective, demands sound technological knowledge to the extension functionaries and therefore MANAGE has focused on training programs on technological aspects in collaboration with ICAR institutions and state agriculture/veterinary universities, having expertise and facilities to organize technical training programs for extension functionaries of state department.

Indian agriculture, water resource and rural development divisions are working in convergence mode to address the challenges of water supply and demand due to the diverse geography, population growth and economic development. To meet the demand and supply with the climate changes and India's complex hydrological systems, a multifaceted approach that includes technology, policy reforms and community engagement is initiated. The watershed management approach has proven to be the most effective method for tackling these issues. The Government of India has also taken initiatives towards the scientific watershed development through Watershed Development Component of Pradhan Mantri Krishi Sinchayee Yojana 2.0.

I would like to extend my appreciation to ICAR-IISWC, Research Centre, Ballari and MANAGE, Hyderabad for the effort in compiling this e-book on “Watershed –Based Natural Resource Management for Drought Proofing” to bring the awareness on the technical aspects of watershed development.

A handwritten signature in blue ink that reads "Yogita Rana". The signature is written in a cursive style and is positioned above a horizontal line.

**(Yogita Rana)**

## Content

| Chapter No. | Chapters   | Page No. |
|-------------|--|----------|
| 1           | Watershed Development under New Generation Watershed Guidelines: An overview<br><i>K Krishna Reddy and Ravi K N</i>  | 1-8      |
| 2           | Drought Assessment and Management- A Case Study on undivided Andhra Pradesh<br><i>Prasanta Kumar Mishra</i>  | 9-18     |
| 3           | Planning and Designing of Water Harvesting Ponds for Drought Mitigation<br><i>B. Krishna Rao</i>   | 19-31    |
| 4           | Ground Water Recharging Techniques for Drought Proofing of Watersheds<br><i>Bhupendra Singh Naik</i>   | 32-37    |
| 5           | Soil & Water Conservation Techniques for Arable and non Arable lands<br><i>B. Krishna Rao</i>  | 38-50    |
| 6           | Water Harvesting Check dams for Climate Resilient Agriculture in Rainfed Regions<br><i>B. Krishna Rao</i>  | 51-55    |
| 7           | Recent Advances (GIS and Remote sensing) in Watershed Planning and Implementation<br><i>M Prabhavathi</i>  | 56-67    |
| 8           | Indigenous & Local Knowledge (ILK) or Indigenous Technical Knowledge (ITK) on Soil and Water Conservation<br><i>Prasanta Kumar Mishra</i>  | 68-75    |
| 9           | Potential Diversified Dryland Horticulture for livelihood enhancement in watersheds<br><i>Anusha N M</i>   | 76-88    |
| 10          | Green cover enhancement techniques in the watershed area<br><i>M.N. Ramesha, H.C. Hombegowda, S.L. Patil, M.R. Jagadish, and S. Raghavendra</i>  | 89-117   |
| 11          | Improved Agronomic Production Technologies for Sustainable Crop Production and Livelihood Improvement in Black and Red Soils of South India<br><i>S.L.Patil M.N. Ramesha and S. Manivannan</i> | 117-137  |
| 12          | Participatory Watershed Management: Cases from TSP and SCSP programs<br><i>A.K. Singh and Gaurav Singh</i>   | 138-150  |
| 13          | Participatory Rural Appraisal (PRA) tools and techniques for watershed planning<br><i>Ravi K N</i>   | 151-164  |
| 14          | Livelihood Interventions for Landless and Skill Development for Youth in Watersheds<br><i>Ravi Dupdal</i>  | 165-174  |



---

## Watershed Development under New Generation Watershed Guidelines: An overview

*K Krishna Reddy<sup>1</sup> and Ravi K N<sup>2</sup>*

<sup>1</sup>Director (ICT& NRM), National Institute of Agricultural Extension Management (MANAGE), Hyderabad

<sup>2</sup>Scientist (Agricultural Extension), ICAR-Indian Institute of Soil and Water Conservation,  
Research Centre, Ballari, Karnataka

---

### Introduction

India is an agrarian economy and agriculture is the prime source of livelihood for more than 70% of the country's population. The total geographical area of the country is 328.7 million hectares. Total of which 139.4 million hectares is net sown area and 202.2 million hectares is the gross cropped area with a cropping intensity of 143.6%. Rainfed agriculture occupies 51% of the country's net sown area and accounts for about 40% of total food production. The negative impacts of Land degradation and climate change such as soil erosion, drought, flood, and cyclone and capricious nature of the monsoon largely witnessed on agricultural production and threatening the livelihood of the farmers. A study states that the total production loss due to water erosion of rainfed areas under major cereal, oilseed, and pulse crops in India was observed to occur at 16%, which in actual physical terms was estimated as 13.4 million tonnes and in economic terms as \$2.51 billion (INR 111.3 billion) (Sharda *et al.*, 2010). Hence, soil erosion control is a pre requisite to achieve the agricultural sustainability in a climate change scenario. Soil erosion can be mitigated using sustainable land management techniques based on the engineering, agronomic, biological and scientific land management practices (Madhu, 2022).

In India, the most prominent source of irrigation is groundwater. Other than groundwater river canals and river dams are important sources of irrigation. Different water harvesting structures also build to expand irrigation to the rainfed regions e.g., contour bunds, graded bunds, rock catchment, semicircular hoop, drought ponds, irrigation dams, farm pond, *etc.* Being the leading state, Punjab achieved 100% irrigation followed by Haryana, Uttar Pradesh, Madhya Pradesh, and West Bengal are the top five states with more than 50% net irrigated area unlike Maharashtra and Jharkhand who have less than 20% of arable land irrigated, thus shows the disparity in water management and distribution among states.

Realizing the significance of water management, Govt. of India launched watershed development programs from 1983-84 to the present Pradhan Mantri Krishi Sinchayee Yojana - Watershed Development Component (WDC-PMKSY 2.0) and several other programs to

develop irrigation facilities in rainfed regions of the country. The aim was to conserve and utilize natural resources for the enhancement of agricultural production and the creation of livelihoods. Watershed is defined as a geo-hydrological unit for an area that drains at a common point. In the past watersheds were managed for soil and water conservation. In the recent past its focus extended to increase agricultural production, the creation of livelihood opportunities in farm and non-farm sectors and maintaining the ecological balance of that region along with soil and water conservation. These initiatives succeeded to cover 40% of Indian agricultural lands under the irrigation facility. Further, it leads to gradual expansion of the agricultural land under irrigation as a result increase in agriculture production in the country.

### **Pradhan Mantri Krishi Sinchayee Yojana (PMKSY)**

Pradhan Mantri Krishi Sinchayee Yojana (PMKSY) was launched on 1<sup>st</sup> July 2015 by GoI. The aim of the program was to complete the ongoing project works, provide irrigation to every farmland of India along with reducing waste of water and improved water use efficiency. It's an umbrella scheme for both irrigation and watershed management. The program is jointly implemented by Ministry of Agriculture and Farmers Welfare, Ministry of Rural Development and Ministry of Jal Shakti, GoI. The objectives of PMKSY are described below:

#### **Objectives of PMKSY**

- Achieve convergence of investments in irrigation at the field level (preparation of district level and, if required, sub-district level water use plans)
- Enhance the physical access of water on the farm and expand cultivable area under assured irrigation (Har Khet Ko Pani)
- Integration of water source, distribution, and its efficient use, to make best use of water through appropriate technologies and practices
- Improve on-farm water use efficiency to reduce wastage and increase availability both in duration and extent
- Enhance the adoption of precision - irrigation and other water-saving technologies (More Crop Per Drop)
- Enhance recharge of aquifers and introduce sustainable water conservation practices
- Ensure the integrated development of rainfed areas using the watershed approach towards soil and water conservation, regeneration of groundwater, arresting runoff, providing livelihood options and other NRM activities

- Promote extension activities relating to water harvesting, water management and crop alignment for farmers and grass root level field functionaries
- Explore the feasibility of reusing treated municipal wastewater for peri-urban agriculture. There are total 4 major components covered under PMKSY.

### Components of PMKSY

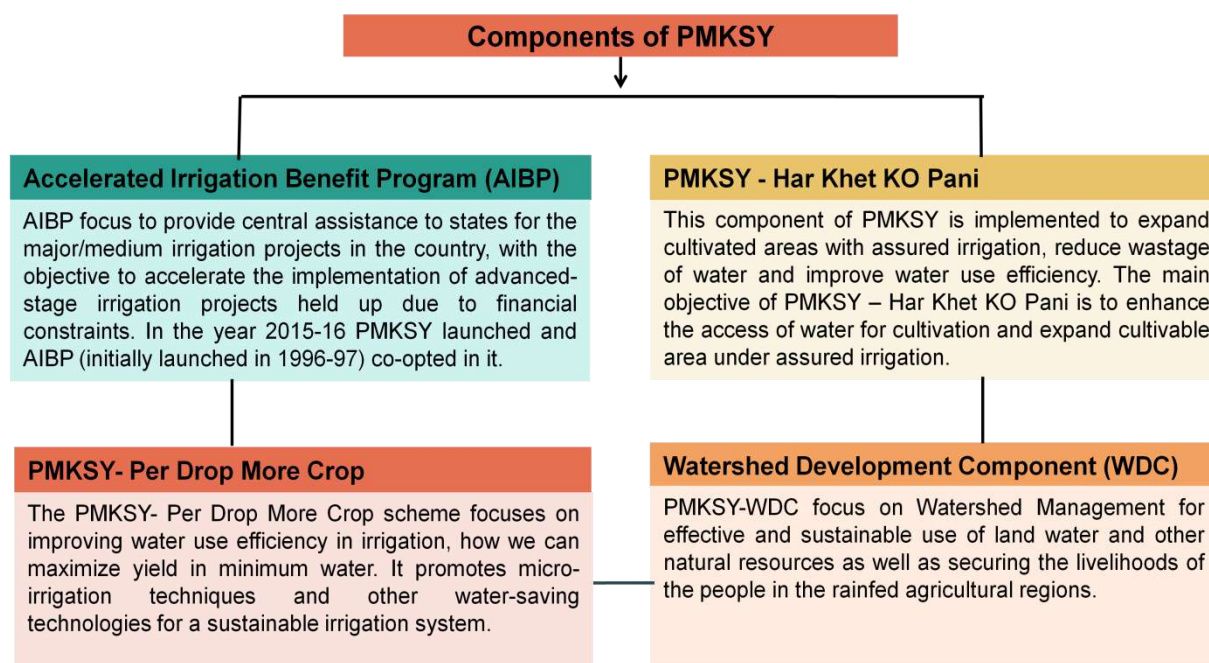

### Watershed Development Component (WDC-PMKSY)

Watershed Management is crucial for effective and sustainable use of land water and other natural resources as well as securing the livelihoods of the people in the rainfed agricultural regions. In this view, Government of India launched, the first phase of WDC-PMKSY in 2015. The second phase of WDC-PMKSY started on 15.12.2021 and the period of the project is 2021-2026 with a target to cover 49.50 lakh ha land under the program and indicative central financial outlay of Rs. 8,134 crores. The program is implemented by the Department of Land Resources under the Ministry of Rural Development. The objectives of WDC-PMKSY as described below:

#### Objective of WDC-PMKSY 2.0 is to

- Improve productive potential of rainfed / degraded land through integrated watershed management.
- Strengthen community based local institutions for promotion of livelihoods & watershed sustainability

- Improve the efficiency of watershed projects through cross learning and incentive mechanism.

### **Watershed Development Approach under WDC-PMKSY 2.0**

The Guidelines for New Generation Watershed Development Projects, 2021 (WDC-PMKSY 2.0) report states that previous experiences with the watershed approach suggest that watersheds are a suitable platform for integrating funding from different programs in order to accelerate the rate of land development within a three to five year time frame. Further, the implementation experiences also necessitate redesigning the watershed treatment approach as follow:

- Transition from current over-emphasis on engineering-centric soil & water conservation at the cost of agronomic and other biological treatments.
- Creation of farm and non-farm-based livelihood opportunities under watershed development.
- For the long-term sustainability of the watershed project demand-side management is essential.

### **Fundamental Shifts in approach of watershed development under WDC-PMKSY 2.0**

New watershed programme guidelines (WDC-PMKSY 2.0), 2021 is envisaged to effect the following shifts in watershed development that need to be included while planning, designing, implementing and monitoring of watershed programmes.

- Recommended for transition from the current major practice of mechanical/engineering treatments to more agriculture engineering measures with focus on trees, cropping systems, soil moisture conservation and soil organic matter.
- Emphasis on realizing effective use of rain water and more on water productivity through integrated measures to enhance water percolation and storage of rainfall water for longer periods through suitable conservation measures.
- Diligent planning of crop systems diversification for risk management; enhancing productivity by adopting drought resistant/less water consuming crops and aligning crop growth phase with water availability, to provide a protective irrigation at critical stages of crop growth.
- Clear risk management plans for adaptation and mitigation of adverse impacts posed by the climate variability and change.

- Promotion of economically vibrant institutions, like Farmers Producers Organizations (FPOs) to promote agri-business services.
- Setting up and nurturing community groups that will take interventions beyond mere creation of assets and promote responsible ownership and management.
- Focus on decentralization, flexibility, community empowerment and providing a greater role for village-level institutions in the planning process with a view to accommodating the local social and traditional strengths.
- Rejuvenation of springs by taking up appropriate watershed activities.

**Cost Norms and Financing pattern in WDC-PMKSY 2.0**

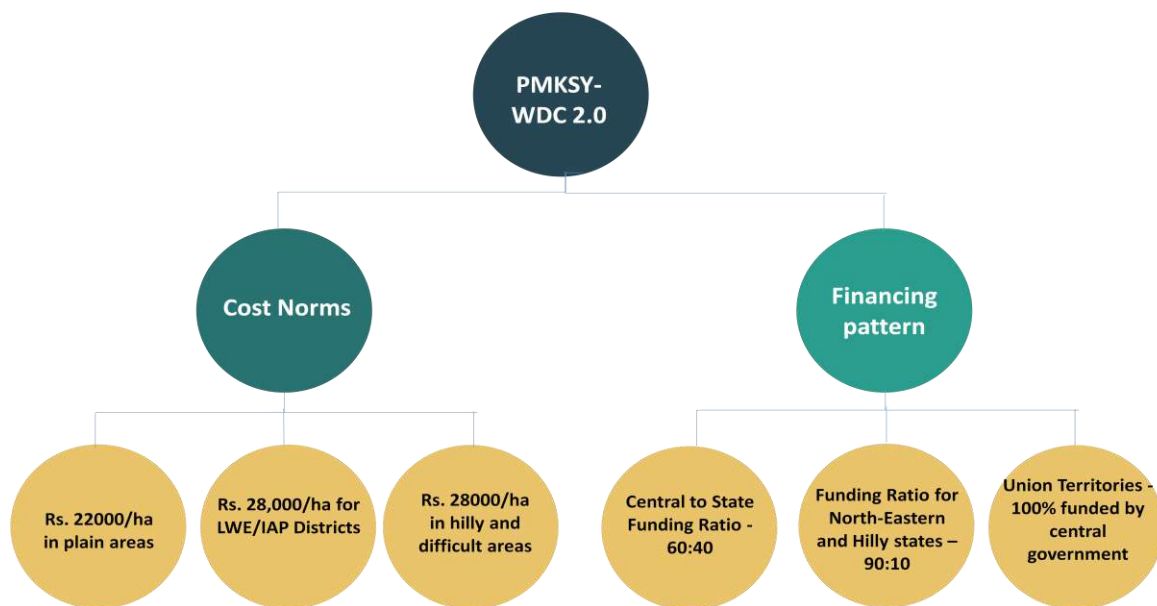

**Project Duration:** The watershed implementation period was decreased to 3-5 Years from 4 to 7 years.

**Institutional Framework of WDC-PMKSY 2.0**

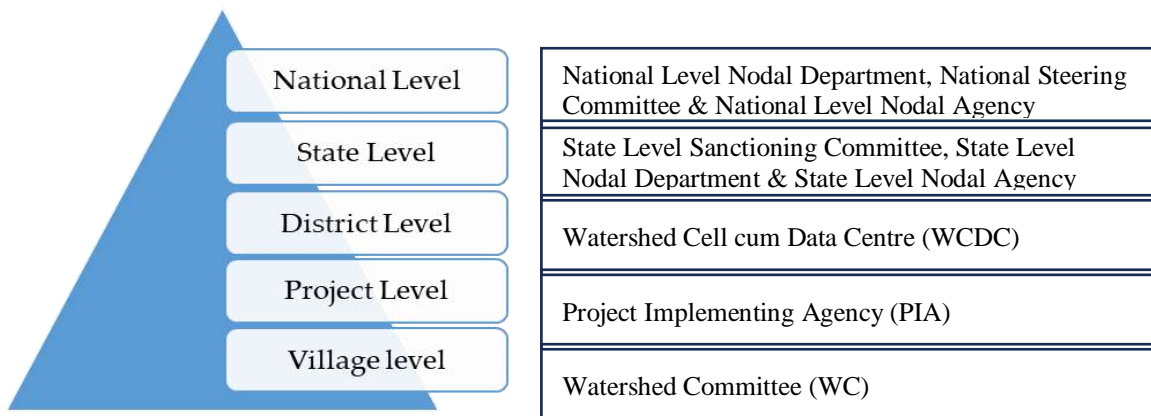

**Fig 1: Institutional framework of WDC-PMKSY 2.0**

## Allocation of Funds in WDC-PMKSY 2.0

**Table 1: Allocation of Funds in WDC-PMKSY 2.0**

| Major Heads                                 | Sub-Heads  | Percentage of budget allocated |
|---|--|--------------------------------|
| <b>Administrative</b>                       | Management Cost  | 10                             |
|   | Monitoring & Evaluation  | 2                              |
| <b>Preparatory Phase</b>                    | Entry Point Activity   | 2                              |
|   | DPR Preparation  | 1                              |
|   | Institution & Capacity Building  | 3                              |
| <b>Works Phase</b>                          | Natural Resource Management  | 47                             |
|   | Production System  | 15                             |
|   | Natural Resource Management & Governance   | 2                              |
|   | Livelihood Activities for the asset less persons, Micro Enterprises & Business Development | 15                             |
| <b>Consolidation &amp; Withdrawal Phase</b> |  | 3                              |
| <b>Total</b>                                |  | 100                            |

(Source: WDC-PMKSY 2.0 Guidelines, 2021)

### Livelihood Aspect in WDC-PMKSY 2.0

The percentage share of the budget for the livelihood aspect in WDC-PMKSY 1.0 was 9%. Realizing the significance, in WDC-PMKSY 2.0 the percentage share of budget for livelihood has been increased to 15%. The major three focus areas of this program are Economy, Ecology, and Equity. The economy and equity aspect deals with the sustainable livelihoods (both farm-based and non-farm-based) opportunities should be created in the watershed intervention area under WDC-PMKSY 2.0. We can turn agriculture profitable in the rainfed and dry land areas by introducing different livelihood options. Some of the major alternative livelihood options to be promoted in watershed include vermicompost preparation, community-based seed production, millet-based value addition, kitchen gardening, custom hiring center, bio-fertilizers production, mushroom production, medicinal & aromatic plant cultivation and extraction and Non-farm livelihood option etc. Further developing such alternative livelihoods in the watershed area can enhance the standard of people's lives and uplift them from poverty.

### **Provision for Land Resource Inventory (LRI) based watershed planning**

Compiling essential site and soil characteristics of the watershed, climatic and hydrological data, and socioeconomic status were used to create LRI database for site-specific watershed planning with use of advanced tools and techniques was emphasised in the PMKSY-WDC 2.0. Therefore, guidelines recommended for at least 10% of watershed projects implemented by states should cover under LRI system.

### **Recent Development in LRI based watershed planning**

Several studies highlighted that large sums of money have been invested in watershed development initiatives over the years, but majority of India's conventional watersheds have not produced desired output at the predicted level (Lalitha et al., 2016; Hegde et al., 2018). The reasons include insufficient planning and execution of site-specific watersheds (Lalitha et al., 2016) and inappropriate use of natural resources at the farm and watershed levels (Hegde et al., 2018). Hence, recently implemented World Bank funded Sujala-III watersheds (2014-2019) in Karnataka state used a site-specific and scientific approach to watershed planning and implementation through the creation of both watershed and farm-level LRI databases (Hegde et al., 2018; Ravi et al., 2022). In the LRI based project (Sujala-III) the micro-watershed-level Land Resource Inventory (LRI) database was used for planning and preparation of DPR. In continuation with the success of the Sujala-III project, World Bank supported multi-state watershed development program called Rejuvenating Watershed for Agricultural Resilience through Innovative Development (REWARD) is planned and implementing in Karnataka and Odisha States for site-specific planning and implementation. The findings of REWARD project would help in setting the National Technical Standards to the country in Watershed Planning, Monitoring and Evaluation

### **Conclusion**

The chapter provides detailed overview of Pradhan Mantri Krishi Sinchayee Yojana (PMKSY) with emphasis on new generation watershed project guidelines for implementation of PMKSY-WDC 2.0 component. Further, it explains the different watershed projects implemented and under implementation in the recent years. Hence, understanding of the shift of conventional method of watershed management to new approaches will helps in effective formulation and planning of watersheds for sustainable management of Natural Resources in the rainfed areas. Therefore, there is a need to understand various components in the planning, monitoring and evaluation of watersheds in the country. Further the subsequent

chapters in the book explains various technical aspects of drought assessment, planning and designing of water harvesting, groundwater recharging techniques, soil and water conservation techniques, recent advances, indigenous and local knowledge on soil and water conservation, participatory watershed management, etc.

## References

- Hegde, R., Niranjana, K. V., Srinivas, S., Danorkar, B. A., & Singh, S.K. (2018). Site-specific land resource inventory for scientific planning of Sujala watersheds in Karnataka, *Current Science*, 115(4), 644-652.
- Lalitha, M., Dharumarajan, S., Natarajan, A., Niranjana, K. V., Srinivas, S., Naidu, L. G. K., & Sarkar, D. (2016). Need for sitespecific land resource database for integrated watershed management, *Indian journal of Soil Conservation*, 44(2), 168-176.
- DoLR and NRAA (2021). Guidelines for new generation watershed Development Projects (WDC-PMKSY 2.0). Published by Department of Land Resources, Ministry of Rural Development and National Rainfed Area Authority, Ministry of Agriculture and Farmers Welfare, Government of India, New Delhi. Pp.91.
- Madhu, M. Soil and Water Conservation Strategies for Sustainable Agriculture in Changing Climate Scenario. In *Community Based Climate Risk Management through Watershed Development*; National Institute of Agricultural Extension Management (MANAGE):Hyderabad, India, 2022; Volume 1.
- Ravi, K.N., Patil, S.L., Biswas, H., Ramesha, M.N., Naik, B.S., Ojasvi, P.R., Dupdal, R., Prabhavathi, M., Kumar, S. and Morade, A.S., (2022). Land Resource Cards: An Innovative Approach to Empower Farmers for Site-Specific Farm Resource Management. *Indian Journal of Extension Education*, 58(1), pp.106-110.
- Sharda, V. N., Dogra, P., & Prakash, C. (2010). Assessment of production losses due to water erosion in rainfed areas of India. *Journal of Soil and Water Conservation*, 65(2), 79-91.



---

## **Drought Assessment and Management-A Case Study on undivided Andhra Pradesh**

***Prasanta Kumar Mishra***

*Former Director, ICAR-Indian Institute of Soil and Water Conservation, Dehradun*

---

### **Background**

In a study on drought by ICAR-Central Research Institute for Dryland Agriculture (CRIDA), twenty-two districts of undivided Andhra Pradesh have been considered except Hyderabad for assessing drought based on various bio-physical and socio-economic parameters. Data were collected from primary and secondary sources. Handbook of statistics of each district and published literature were referred. Primary survey was conducted in 66 villages, three villages per district to assess the impact of drought on socio-economic aspect of various sections of the society. The various parameters studied are rainfall and its variation, frequency of drought of various types (meteorological, hydrological, agricultural), status of groundwater, drinking water, feed and fodder availability and use of remote sensing for assessing drought. Software has been developed for assessing drought, while procedure for data collection and proformae have been reviewed and modified suitably.

### **Rainfall and Co-Efficient Of Variation (CV)**

Andhra Pradesh represents a transition from tropical to sub tropical India. The climate is predominantly semi arid to arid, except for the coastal belt, which has semi-arid to sub humid climate. Occurrence of rainfall in Andhra Pradesh is influenced by South West and North East monsoon. The South West monsoon establishes over Andhra Pradesh during the second week of June, normally by June 10. The withdrawal of South West monsoon begins from last week of September and it retreats South of Andhra Pradesh by the end of October. At about the same time, the North East monsoon sets in and the activity of North East monsoon is generally experienced over Coastal and Rayalaseema regions of Andhra Pradesh. Region-wise rainfall analysis indicates that Telangana, Coastal Andhra and Rayalaseema regions of the state receive 82, 59 and 55 per cent of the annual rainfall, respectively during South West monsoon. The North East monsoon contributes only 11 per cent in Telangana region while the Coastal and Rayalaseema region receive over 30 per cent of the annual rainfall during this period.

The analysis of available rainfall data at mandal level indicates an average annual rainfall of 911 mm for Andhra Pradesh. The coefficient of variation of rainfall varies between 25 to

35%. The rainfall of 10 districts falls below the average annual rainfall of AP. Anantapur district receives the lowest amount of rainfall and Visakhapatnam receives the highest. Of all the districts, Prakasam, Nellore and Chittoor receive major amount of rainfall from October to December through North-East monsoon, while other districts receive through South–West monsoon. The contribution of off-season rainfall during the hot summer and winter is little. Similar analysis has been carried out for all the mandals.

### Drought Frequency

Frequency of meteorological, hydrological and agricultural droughts was analyzed to assess the vulnerability of mandals to different types of drought. Mandals having daily rainfall data of more than 20 years were considered for the analysis of agricultural drought.

### Meteorological Drought

Meteorological drought may be defined as the deficiency of rainfall from the normal over a given period of time. Different mandals were categorized as drought prone considering normal rainfall and the tolerable deficiency in rainfall as followed by GoAP (1995) (Table 1).

**Table 1: Categorization of meteorological drought on the basis of rainfall and its deficiencies.**

| Rainfall | Range of normal rainfall (mm) | Rainfall deficiency and frequency for drought categorization |               |
|----------|-------------------------------|--|---------------|
|          |                               | Rainfall deficiency (%)                                      | Frequency (%) |
| Low      | < 750                         | 15   | ≥ 20          |
| Medium   | ≥ 750 < 1000                  | 20   | ≥ 20          |
| High     | ≥ 1000                        | 25   | ≥ 20          |

Frequency of droughts was analyzed for all the mandals using historical rainfall data. Drought prone mandals with respect to meteorological drought for each district were identified (Fig. 1). It is evident all the districts, except Vizianagaram, experience drought once in five years and Anantapur once in three years. Other districts drought frequencies are in between.

### Software for real time assessment

Software has been developed to assess the meteorological drought in a real time mode. Daily rainfall is the input for the model. The output gives up-to date report of rainfall status and its deviation on daily, weekly, monthly, seasonal and annual time scales. The cumulative rainfall is compared with respective normal values of weekly, monthly, seasonal and annual rainfall. Further, the cumulative rainfall is compared with the threshold value to estimate the per cent

deviation of the rainfall from threshold and the time of crossing the threshold. Non-achieving of threshold value indicates drought situation, which is also presented graphically using the same software.

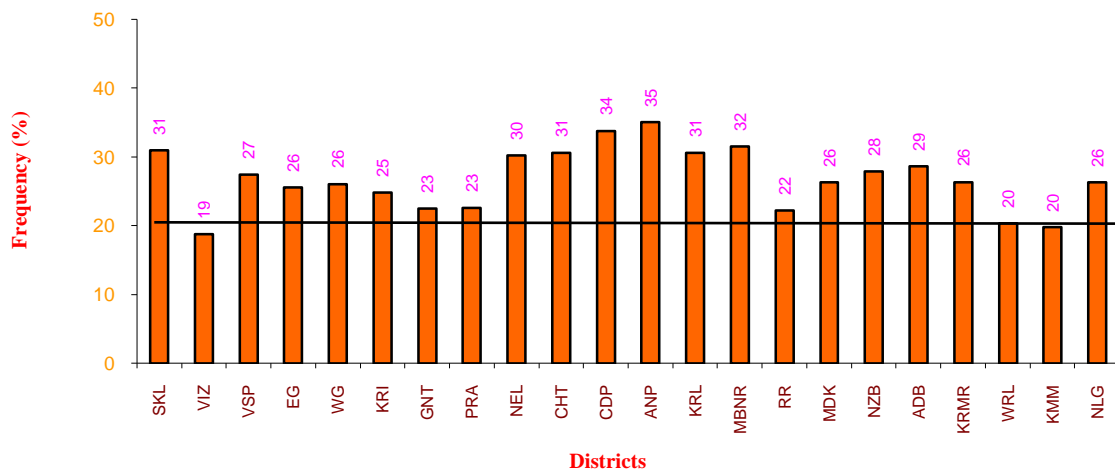

**Fig. 1 Meteorological drought frequency of different Districts**

### Hydrological Drought

Prolonged meteorological drought results in a marked depletion of water resources and consequent drying up of reservoirs, lakes, streams and rivers, cessation of spring flows and also a fall in ground water level. Hydrological drought, thus, refers to the deficiencies in surface and subsurface water supplies in streams, surface reservoirs and groundwater. Runoff from rainfall is the major source for flow of water in streams and replenishing reserves in reservoir and ground water. Runoff-producing rainfall is considered for evaluating the hydrological drought for different mandals (as the data on rainfall is mostly available). The runoff-producing rainfall is estimated using widely accepted SCS curve number (CN) method taking into account soil type, land use, antecedent moisture condition and average slope of the area.

### Runoff Estimation Using Curve Number Technique

The CN method defines a retention parameter  $S$  (mm), which varies with time because of changes in soil moisture content. The parameter  $S$  is related to CN by the following relationship:

$$S = ((1000/CN) - 10) \times 25.4 \dots\dots\dots (1)$$

The values of the CN vary with antecedent moisture condition (AMC). In the original procedure of USDA and its Indian adaptation, three such conditions are defined as AMCI, AMCII, and AMCIII, corresponding to dry, average, and wet catchment conditions, respectively (USDA, 1972). These conditions are identified empirically based on the cumulative rainfall in the 5 days preceding the current rainfall event during the rainy season. Limiting values of the cumulative rainfall of the previous 5 days are defined for identifying the AMC. If the rainfall is <35 mm, then AMCI applies; if it is more than 52.5 mm, AMCIII applies; and if it is in between 35 and 52.5mm, AMCII applies.

The values of the CN for average AMC (CN for AMCII i.e.CNII) are taken from standard table for various soil, land use, and management conditions. The corresponding values of CN for dry (CNI) and wet (CNIII) catchments conditions are given by:

$$CNI = (4.2 \times CNII) / (10 - 0.058 \times CNII) \dots\dots\dots (2)$$

$$CNIII = (23 \times CNII) / (10 + 0.13 \times CNII) \dots\dots\dots (3)$$

The average condition CN (CNII) was decided on the basis of hydrologic soil group and land use pattern considering the standard land use data available with the Chief Planning Officer (CPO) of the respective district (GoAP 1995-2000). Weighted CN was calculated considering the proportion of area under different types of land uses. The slope factor is considered for upgrading the CN value for final use. The average slope is interpolated from slope map. The soil types are extracted from the map prepared by NBSS & LUP (ICAR), Nagpur. The CNI and CNIII were calculated from equations 2&3 respectively. Corresponding S1, S2, and S3 values were calculated from eq.1 using the CN1, CN2, and CN3 values. The runoff (R) for corresponding rainfall (P) where rainfall is greater than 0.2S was calculated using equation (4). For this, available daily rainfall and land use data (mandal-wise) were collected from Planning Department, GoAP.

$$R = (P - 0.2S)^2 / (P + 0.8S) \dots\dots\dots (4)$$

Knowledge of the extent of water resources availability in the district is of vital importance in identifying the hydrological drought. As per the definition of Central Water Commission, a particular year may be considered as hydrological drought year if the runoff is less than 75% of the normal runoff (IWRS, 2001). With the above techniques, the runoff -producing rainfall, corresponding to the individual runoff events for each mandal, was calculated. In the present study, 80% of the runoff-producing rainfall is considered as threshold value for assessing hydrological drought. In other-words, if the runoff is less than 20% of the normal

runoff, then, it is considered as hydrological drought year. The analysis of data indicates that all the districts are prone to hydrological drought once in five years (Fig.2). The severity of hydrological drought is more than the meteorological drought. Mandal-wise information on hydrological drought for each district is presented in the software.

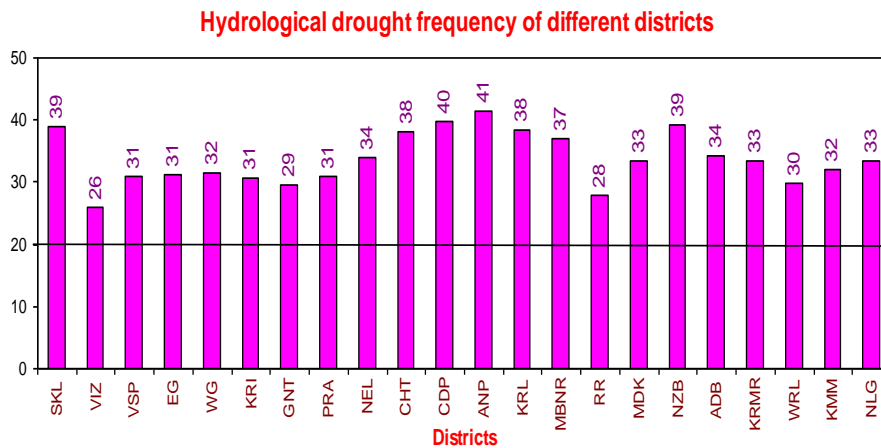

**Fig. 2: Hydrological drought frequency of different districts**

## Software for real time assessment of Hydrological drought

### Runoff-producing rainfall

Software has been developed for assessing the hydrological drought on real time and to get first-hand information on the runoff-producing rainfall events. An average value of the amount of daily rainfall, which is causing runoff, has been estimated for each district for using it in the software. The input to this model is daily rainfall. A threshold value of runoff-producing rainfall for each mandal was estimated considering the long-term average values. The output produces up-to-date report on the occurrence of runoff-producing rainfall showing deviations from the threshold value for the mandal. When the runoff-producing rainfall is less than 80% of the normal (threshold value), it is considered as hydrological drought year. The report is also displayed graphically using the same software. The daily and monthly cumulative values are compared with the threshold to estimate the percentage deviation and the time of crossing the threshold. Non-crossing of threshold value indicates hydrological drought situation, which is presented graphically in daily and monthly graphs.

### Storage Water Levels in Reservoirs

State Governments collect data on the levels of stored water in important reservoirs through its Irrigation Department. Reservoir storage level is an useful indicator of water shortages. As data on reservoir storage are available on a regular basis, these could provide accurate

information on water shortages. The Central Water Commission maintains data on water levels, where the water storage is compared with the Full Reservoir Level (FRL). State Governments need to plan the use of reservoir storage as per the in reservoir operation rules, which lay down the priority for the use of available water: drinking water, urban and industrial use and irrigation for agriculture. Reservoir water level may fall below the expected level even when the reservoir operation rules are not followed and the usage of water is not adequately regulated.

### **Agricultural Drought**

Andhra Pradesh is basically an agricultural State, with 34% of its GDP contributed by agriculture. Agriculture is the major source of employment to the people. Droughts during the season affect the agricultural production and agricultural droughts of high severity cripple the economy of the State. To assess the agricultural drought, it is necessary to measure the extent to which rainfall and soil moisture are falling short of the water requirement of crops during the cropping season. Moisture Adequacy Index (MAI) is a better measure for assessing the degree of adequacy of rainfall and soil moisture to meet the potential water requirement of crops. Hence, to identify the mandals that can be vulnerable to agricultural drought, weekly MAI was worked out for the mandals having more than 20 years of rainfall data.

### **Surface Water and Groundwater Level**

Natural discharge from shallow aquifers provides base flow to streams and sustains the water in lakes and ponds, particularly during periods of dry weather. Similarly, ground water levels are also affected due to poor recharge, either due to lack of adequate rainfall or poor water conservation practices. As a result, water availability in deepbore-wells and openwells diminishes substantially. Declining ground water levels are important indicators of drought conditions, though these are often attributed to over-extraction of water. An annual decline in the water table of up to 2 metres is considered normal and can tolerate even a deficient rainfall the following year. A decline of up to 4 metres is a cause for concern and above 4 metres is a stress situation. Most of the State Governments have similar groundwater boards or agencies for surveying groundwater levels and their periodical reports provide information upon declining groundwater levels.

**Methodology for calculating MAI**

Moisture Adequacy Index (MAI) is the ratio of actual evapotranspiration (AET) to the potential evapotranspiration (PET). AET can be obtained as an output parameter from water balance calculations. Thornthwait and Mather (1955) weekly water balance model was used for estimating water balance of mandals. In each district, mandals with more than 20 years of data were selected and water balance of those mandals was worked out. The weekly water balance parameters like weekly AET, surplus, deficit etc. for weeks 1 to 52 were worked out for such mandals. Weekly MAI for weeks 1 to 52 were worked out as ratio of weekly AET and PET values. As Agricultural droughts occur during the cropping season only, average MAI during the cropping season has been taken as the yard stick for assessing the intensity of agricultural droughts. The available information has been used for determining the average MAI during the cropping season (rainy season). Agricultural droughts during different seasons (years) were classified into four groups based on average MAI during the season (Table 2).

**Table 2: Drought classification based on MAI**

| Drought severity | MAI                 |
|------------------|---------------------|
| No drought       | MAI > 0.75          |
| Mild drought     | MAI <0.75 and >0.50 |
| Moderate drought | MAI <0.50 and >0.25 |
| Severe drought   | MAI <0.25           |

Frequencies of all the categories of agricultural drought like mild, moderate and severe were added to work out the drought frequency of a mandal. Districts having drought frequency less than or equal to 20% were classified as safe, more than 20 or less than or equal to 40% as moderate and more than 40% as severe. Based on the above classification, districts were categorized as safe, moderate and severe.

**Drought Severity Index (DSI)**

Considering the agricultural drought frequency (number of years of different types of drought like mild, moderate and severe) and the severity based on MAI, an index called drought severity index has been devised (Eqn.5). The formula for working out drought severity index (DSI) is as follows:

$$(0.0 * \text{No drought} + 0.25 * \text{Mild droughts} + 0.50 * \text{Moderate droughts} + 0.75 * \text{severe droughts})$$

$$\text{DSI} = \frac{\hspace{15em}}{\hspace{15em}} \times 100 \dots (5)$$

Total number of years

As these indices like drought intensity and drought frequency were estimated for mandals having more than 20 years of rainfall, the need for extrapolating the indices to all 1099 mandals arose. A novel methodology has been developed for extrapolating these indices for the rest of the mandals of the district. First of all, regression equations between DSI and mean rainfall of the mandals (with >20 years data) were developed. Later, in the equations so developed, mean rainfall of each mandal was incorporated to workout the DSI of all mandals in a district. This type of exercise was done separately for each district of the State. A similar approach was adopted for the drought frequency also. Data of drought intensity and drought frequency of all the 1099 mandals of 22 districts (Hyderabad excluded due to total urban area) are presented district-wise in the software. The data show that intensity and frequency of agricultural droughts are not uniform across the mandals of district and some are more vulnerable and some are less vulnerable. Based on drought severity index, mandals were classified into 4 categories viz. safe, less vulnerable, moderately vulnerable and highly vulnerable. This categorization was made using the mean (M) and standard deviation ( $\sigma$ ) of drought severity index over all the mandals of the state. The methodology for categorization of mandals and the limits of DSI are presented in (Table 3). Accordingly, mandals with  $DSI \leq 3$  were marked as safe (SF);  $DSI > 3$  and  $\leq 13.5$  as less vulnerable (LV);  $DSI > 13.5$  and  $\leq 24$  as moderately vulnerable (MV) and  $DSI > 24$  as highly vulnerable (HV).

**Table 3: Drought classification based on DSI**

| Category                   | DSI                                     |
|----------------------------|---|
| Safe (SF)                  | $\leq (M - \sigma)$                     |
| Less vulnerable (LV)       | $> (M - \sigma)$ and $\leq \text{Mean}$ |
| Moderately vulnerable (MV) | $> \text{Mean}$ and $< (M + \sigma)$    |
| Highly vulnerable (HV)     | $> (M + \sigma)$                        |

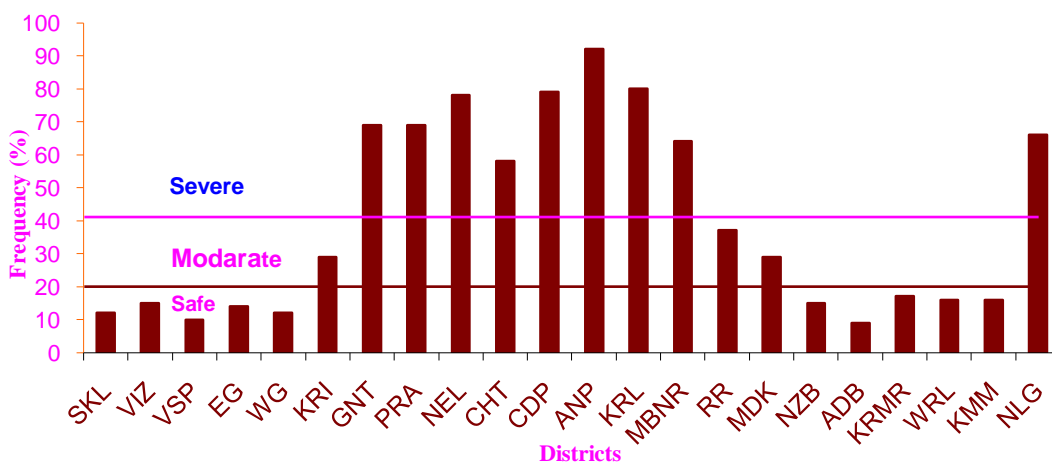
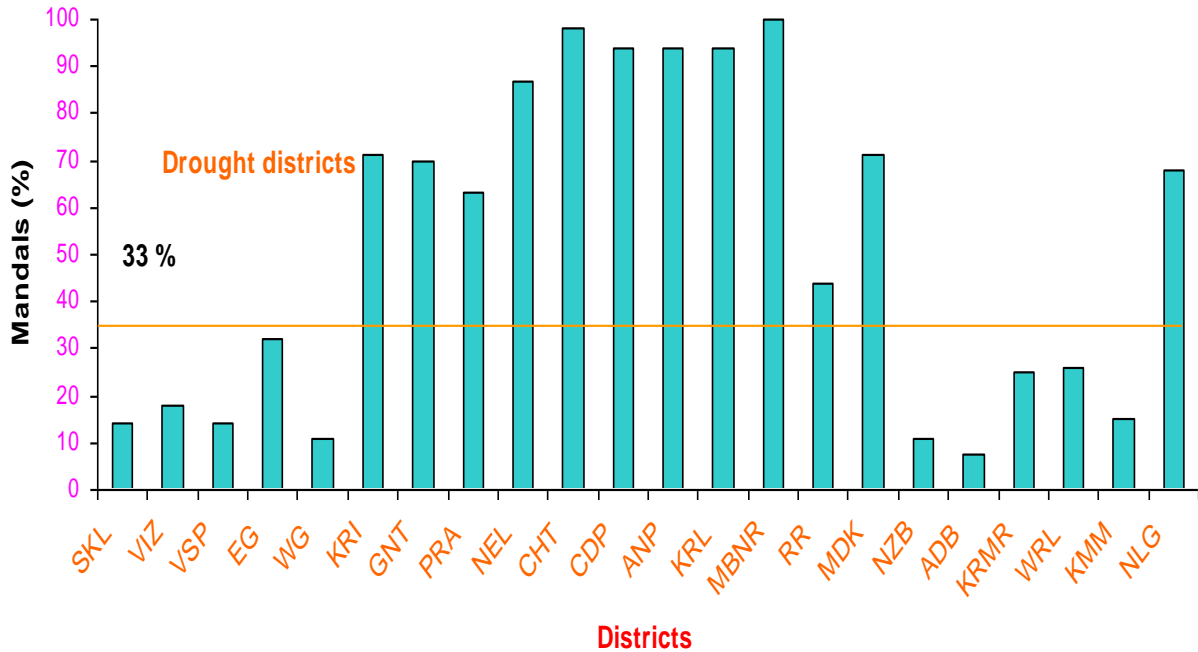

**Fig 3: Aricultural Drought Frequency of different districts**



### Integration of Meteorological, Hydrological and Agricultural Droughts

The mandals having all the three types of drought (frequency >20%) were analyzed and presented in Fig.4. The figure indicates that 12 districts covering 33% mandals are prone to all the three types of drought.



**Fig. 4: Percent mandals prone to meteorological, hydrological and agricultural droughts**

### Socio-Economic Drought

The impact of drought was assessed for all the four categories of vulnerable sections of a rural society, namely farmers, women, artisans and landless. The groups were interviewed using a structured schedule separately in three villages of 22 districts. Villages prone to drought in different revenue zones of a district were identified with the help of revenue officials. These groups were interviewed using a structured schedule in three villages of 22 districts of Andhra Pradesh, except Hyderabad. An attempt was made to record the farmers' perceptions for identifying drought prior to its occurrence taking into consideration their indigenous knowledge and wisdom. People in all the districts of Andhra Pradesh have reported recurring phenomenon of drought in the past decade. Chittoor and Cuddapah were the major affected districts which suffered continuously for the last one-decade followed by Anantapur, Rangareddy, Mahbubnagar, Nalgonda, Warangal, Medak and Nellore (8 years). They suggested that the departments of agriculture, meteorology, and revenue and agricultural research institutes, etc should do the drought assessment jointly. However, the year 2002 was recorded as the most severe drought year in all the districts of the State. Erratic

distribution of rainfall and poor amount of rainfall were considered as the main reasons of occurrence of severe drought. Media (Radio, T.V. and Newspapers) played a minor role in creating awareness about drought and there was no effective mechanism at the district level. However, the farmers have their own wisdom of identifying drought prior to its occurrence.

### Drought Management Strategy

## Drought Management Strategy

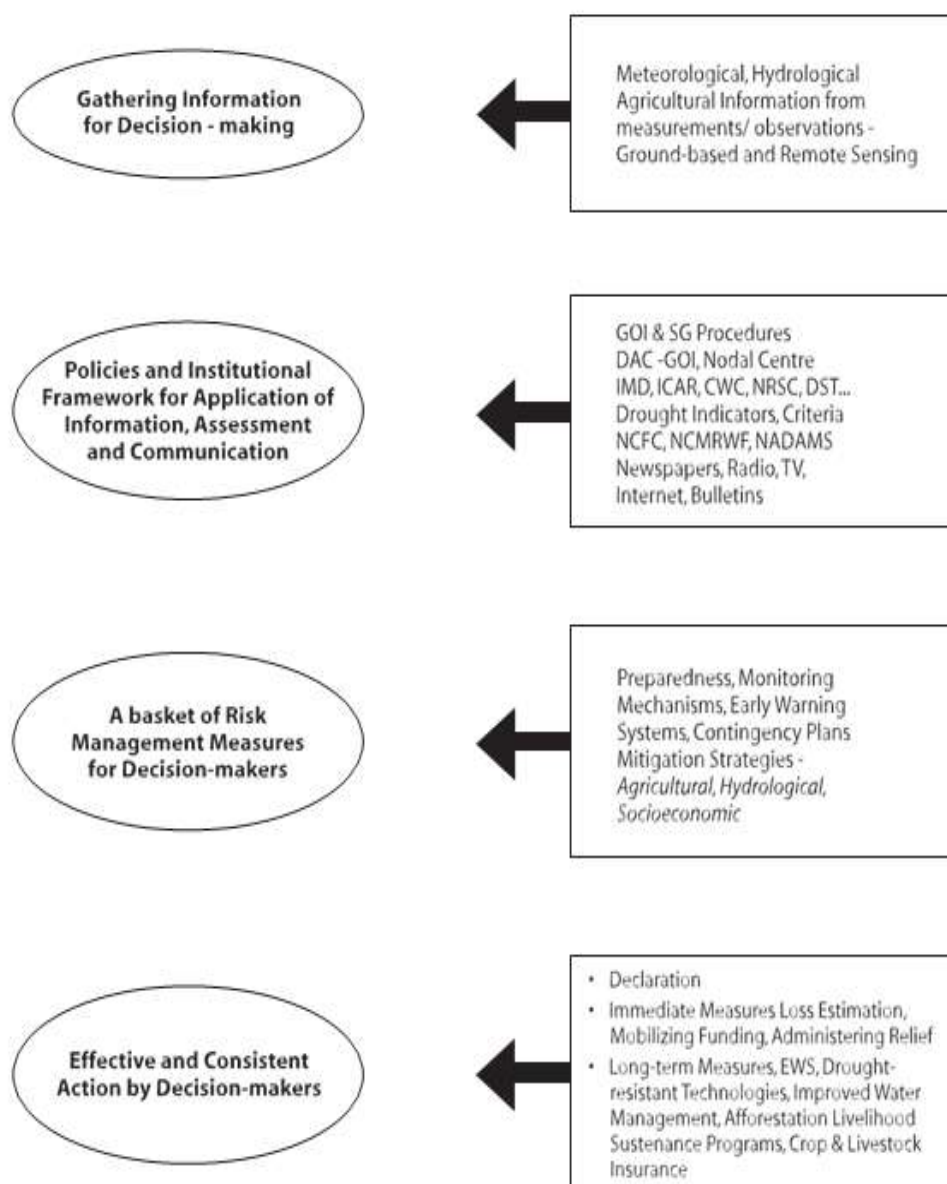

Source: Drought Management, Ministry of Agriculture

---

## Planning and Designing of Water Harvesting Ponds for Drought Mitigation

**B. Krishna Rao**

*Head & Pr. Sci (SWCE), ICAR-Indian Institute of Soil & Water Conservation,  
Research Centre, Ballari, Karnataka*

---

### Background

The water harvesting term was firstly used in Australia by H.J. Geddes, to denote the collection and storage of any form of water either runoff or creek flow for irrigation use. This nomenclature has since then used very commonly, for expressing the meaning as collection of rainfall and all other water amounted to the same things. In the above definition, water harvesting includes stream flow in creeks and gullies, not just rainfall at point where it falls; therefore water harvesting term is used to indicate the collection of any kind of water.

### Importance

It is well known that, the land pressure is increasing day by day due to population growth, causing the more and more marginal lands are being used for agriculture. The agriculture is only possible when there is availability of water. Although at every place, there is ground water, but its exploration needs money, as a result it becomes a constraint. However, by water harvesting during rainy season, the water availability can be formed, investing least cost. In arid, semi-arid and sub-humid areas where rainfall pattern is irregular, ranges from heavy to fewer storms and much of this rainfall is lost as surface runoff, as a result there is scare of water and results into the risk of human being. Although, in this situation artificial supply of water to fulfil the demand may provide an obvious response to the water scare but it is proved more costly. Under such condition the water harvesting is a substitute and is most important. The sources of water that are to be harvested are the roof water, sheet flow or intermittent and even perennial water. The harvested water can be used for various productive purposes such as domestic water supply, creating stock of water for irrigation of the crops, trees and also for fish farming.

### Harvesting Principles

The design principle of water harvesting structures is similar to the other hydraulic structures requiring a wide range of input. In many regions local thumb rules are used for designing the structures. For hydrological design a more or less universal criterion is followed which is basically "the ratio of the catchment area to the cultivated area." Where this ratio is known or assumed, the possible size of field to be irrigated by harvested water can easily be

determined. The size of catchment can be assessed either by conducting field survey to estimate in the field or measured from the topographic map of the catchment, provided that the map is available. In several parts of world, the value of thumb rule varies from 1:5 to 1:40, depending on rainfall magnitudes and its distribution; watershed characteristics, runoff coefficient and water requirements of the existing crops to be irrigated.

### **Water Harvesting Ponds**

Ponds are small tank or reservoir like constructions, are constructed for the purpose of storing the surface runoff, generated from the catchment area. The Farm ponds are water harvesting structures, solve several purposes of farm needs such as supply of the water for irrigation, cattle feed, fish production etc. Farm ponds also play a key role in flood control by constructing them in large numbers in the area. In addition, the farm ponds are also used for storing the monsoon water, which is used for irrigation of crops, and several other purposes, according to the need. A farm pond also has significant role in rainfed farming cultivation

### **Type of ponds**

Depending upon the sources of water and their location with respect to the land surface, farm ponds are grouped into three types.

1. Earthen embankment pond.
2. Embankment cum dugout farm pond.
3. Dugout pond.

### **Site selection**

Selection of suitable site for the pond is important as the cost of construction as well as the utility of the pond depend upon the site.

- The site for the pond is to be selected keeping in view of the following conditions.
- The site should be such that largest forage volume is available with least amount of earth fill; a narrow section of the valley with steep side slope is preferable.
- Large area of shallow water should be avoided as these will cause excessive evaporation losses and also cause watersheds to grow.
- The site should not cause excessive seepage losses.

- The pond should be located as near as possible to the area, where the water will be used. When water is to be used for irrigation, gravity flow to the areas to be irrigated is preferable.
- Pollution of the farm pond water should be avoided from drainage, from farmsteads, sewage lines and mine dumps.

### Capacity of ponds

The capacity of the pond is determined from contour survey of the site at which pond is to be located. From the contour plan of the site, the capacity is calculated for different stages.

For the purpose, the area enclosed by each contour is measured using planimeter, the volume between two contours at an interval of contour (d) and having areas A1 and A2 is given by

$$V = \frac{d}{2} (A1 + A2)$$

### Example:

Calculate the capacity of a pond given the area enclosed by different contours at the site as follows :

| S.No. | Contour values (m) | Area enclosed (Sq.m) |
|-------|--------------------|----------------------|
| 1     | 250                | 220                  |
| 2     | 251                | 290                  |
| 3     | 252                | 340                  |
| 4     | 253                | 370                  |
| 5     | 254                | 480                  |
| 6     | 255                | 550                  |
| 7     | 256                | 620                  |

$$\text{Vol. (cm)} = 1 \times 100/2 [2.2+ 2.9 + 3.4 + 3.7 + 4.8 + 5.5]= 2450 \text{ cum}$$

(b) The storage capacity of the pond can be roughly calculated from the formula.

Storage capacity (ha.m) = 0.4 D.A.

Where,

D = Maximum depth of water (m)

A = area of water spread behind bunds ha

### i. Earth work computation

#### i. Embankment top width.

Normally the top width of the embankment is fixed by the equation.

$$W = \frac{Z}{5} + 5$$

Where,

W = Width of crest (m)

Z = height of embankment above the stream bed (m)

Where the top of the embankment is to be used for roadway, the top width should be provided for a shoulder on each side of the traveled way to prevent raveling. The top width in such cases should not be less than 4.5 m.

### ii. Embankment side slope

The side slope of the dam depends primarily on the stability of the material in the embankment. The greater the stability of the fill material, the steeper can be side slope. The more unstable materials require flatter side slopes.

Table 2: Recommended side slope for the earthen embankments.

| Soil classification   | Slope                           |         |
|---|---------------------------------|---------|
|   | U/S                             | D/S     |
| Well graded gravels, sand, gravel, mixtures little or no fines.                 | Previous and hence not suitable |         |
| Clayey gravels, silty gravels sand clay mixtures and gravel sand silt mixtures. | 2.5 : 1                         | 2 : 1   |
| Sand clays, silty clays, lean clays inorganic silts and clays                   | 3 : 1                           | 2.5 : 1 |
| Inorganic clays of high plasticity and inorganic silts                          | 3.5 : 1                         | 2.5 : 1 |

### iii. Free board

Free board is the added height of the dam, provided as a safety factor to prevent waves or runoff from storms greater than the design frequency for over topping the embankment. It is the vertical distance between the elevations of the high flood level, after all settlement has taken places. Normally 15% is adopted as free board.

#### iv. Allowance for settlement

Settlement includes the consolidation of fill materials and the consolidation of the formation materials due to self weight to fill material and the increased moisture caused by the storage of water. Settlement or consolidation depends on the character of the materials in the dam and foundation, and on the methods and speed of construction. The design height of earth dams should be increased by an amount equal to 5% of design height.

#### Earth work computation

To estimate the borrow required should include the dam, allowances for settlement, backfill for the cutoff trench, backfill for the existing stream channels and the holes in the foundation area etc. The common methods of estimating the volume of earth fill is the sum of end area method with the fill heights, side slopes and top width established, the end area of the X-section at each station along the center line is used for computation of earth work.

**Example –:** An earthen embankment with a top width of 2.0m is proposed for construction across a valley, whose fill heights at every 10m. The section has side slopes 2 : 1. A core trench having 0.75 m depth, bottom width of 1.75m and side slopes of 1:1 is also under consideration. Calculate the earth work needed for embankment. The fill heights at 10m interval are from one side area 1.45, 1.85, 2.30, 2.85, 4.2, 5.0, 4.4, 2.9, 2.0, 1.25m.

#### Solution

The area of cross-section at every 10m interval may be computed in the first instance.

$$A = BD + nD^2$$

Where B = 2 m and n=2

Therefore  $A = 2 D + 2D^2 = 2 (D+D^2)$

| D    | D <sup>2</sup> | D + D <sup>2</sup> | X –section area= 2 (D+D <sup>2</sup> ) (sq.m) |
|------|----------------|--------------------|---|
| 1.45 | 2.10           | 3.55               | 7.11  |
| 1.85 | 3.42           | 5.27               | 10.55   |
| 2.30 | 5.29           | 7.59               | 15.18   |
| 2.85 | 8.12           | 10.97              | 21.95   |
| 4.20 | 17.84          | 21.84              | 43.68   |
| 5.00 | 25.00          | 30.00              | 60.00   |
| 4.40 | 19.36          | 23.76              | 47.52   |
| 2.90 | 8.41           | 11.31              | 22.62   |
| 2.00 | 4.00           | 6.00               | 12.00   |
| 1.25 | 1.56           | 2.81               | 5.63  |

Using the principle of sum of end area method, the earth work needed can be computed. The sample calculations are presented below:

| Fill ht. (m) | End area (sq.m) | Sum of end area (Sq.m) | Distance (m) | Double Volume (cum) | volume (cum) |
|--------------|-----------------|------------------------|--------------|---------------------|--------------|
| 0            | 0               | 7.11                   | 10           | 71.10               | 35.50        |
| 1.45         | 7.11            | 17.65                  | 10           | 176.50              | 128.62       |
| 1.85         | 10.55           | 26.73                  | 10           | 257.30              | 128.62       |
| 2.30         | 15.18           | 37.12                  | 10           | 371.20              | 185.60       |
| 2.85         | 21.94           | 65.62                  | 10           | 656.20              | 185.60       |
| 4.20         | 43.68           | 103.68                 | 10           | 1036.80             | 328.10       |
| 5.00         | 60.00           | 107.52                 | 10           | 1075.20             | 537.60       |
| 4.40         | 47.52           | 70.14                  | 10           | 701.40              | 350.70       |
| 2.90         | 22.62           | 34.62                  | 10           | 346.20              | 173.10       |
| 2.90         | 12.00           | 17.62                  | 10           | 176.20              | 88.10        |
| 1.25         | 5.62            | 5.62                   | 10           | 56.20               | 28.10        |
| 0            | 0.00            |                        |              |                     |              |
| Total        |                 |                        |              |                     | 2462.09      |

The above computation should shows only the volume of earth work required to complete dam itself. An estimate of the volume of earth required to fill core trench etc should be made and added to the estimate made for the dam.

Av. depth = 0.75m

Bottom width= 1.75m

Side slopes = 1: 1

Length = 110 m

Area of X-section

$$\begin{aligned} Z &= 1.75 \times 0.75 + 2 \times 0.75 \times 0.75 \\ &= 1.31 + 1.23 = 2.44 \end{aligned}$$

Volume of backfill = 2.44 x 110 = 268 cum

Total earth work needed for dam, works out to be

$$268 + 2462 = 2730 \text{ cum}$$

### Dug out farm pond

Where topography does not lend itself to embankments construction, dugout or excavated ponds can be constructed in relatively flat terrain. Since dugout ponds can be constructed to



expose a minimum water surface area in proportion to volume, they are advantageous where evaporation losses are high and water is scarce.

### **i. Selection of site**

Some of the important physical features that must be considered in locating dugout sites are the watershed characteristics, silting possibilities, and topography and soil type. The watershed must be capable of furnishing the annual runoff sufficient to fill the dugout. Division ditches are often used in adding supplemental drainages. The low point of a natural depression is often a good location for a dugout pond. Location with favorable discharge condition should be selected.

The soil type at the site should be thoroughly investigated to determine the permeability of the soil that will form the bottom and sides of the dugout, as well as to avoid cutting in very hard stuff. In case the seepage rates of farm ponds are excessive, suitable lining may have to be resorted to (ex. Puddling and compacting to the optimum bulk density, bitumen spray, etc.) Soils underlain by limestone containing crevices, sinks or channels should be avoided.

### **ii. Planning**

Excavated ponds may be constructed to almost any shape desired; however a rectangular shape is usually convenient. The size of the pond depends on the extent of area draining into the pond, the extent of area that could be put under pond and its surrounding bund of excavated soil, the amount of money considered appropriate to invest, the nature and amount of rainfall, soil type and expected runoff into the pond. The length and width of an excavated pond will not ordinarily be limited, except that the type and size of the excavating equipment, if used, may become a factor for consideration. The side slopes of a dugout pond should not be steeper than the natural angle of repose of the material being excavated. In most cases, the side slopes should be flatter than 1 : 1.

### **iii) Design of pond**

The storage capacity of the pond is calculated by USDA-NRCS curve number method. Curve number method as follows

$$Q = (P - I_a)^2 / (P - I_a + S)$$

Q= Runoff , P= Rainfall, I<sub>a</sub>= Initial abstraction,

S= potential maximum retention, If I<sub>a</sub>= 0.2S, then

$$Q = (P - 0.2S)^2 / (P + 0.8S)$$

$$S = (25400/CN) - 254$$

CN: curve number

CN depends on, Rainfall characteristics, Watershed characteristics, Land use, Land treatment, Hydrologic soil group, Hydrological condition

**Hydrological condition**

|             |  |
|-------------|--|
| <b>Poor</b> | <b>Less than 50% land is covered by canopy (Heavy run-off)</b> |
| <b>Fair</b> | <b>50-75% land is covered by canopy (Mdiom run-off)</b>        |
| <b>Good</b> | <b>More than 75% land is covered by canopy (Less runoff)</b>   |

**Hydrologic soil group**

| Soil group | Description  |
|------------|--|
| <b>A</b>   | Lowest runoff potential includes deep sand with very little silt and clay, rapidly permeable layers (>25 mm/hr)  |
| <b>B</b>   | Moderately high run-off potential mostly sand soils less deep than A and loess less deep than A (12.5-25 mm/hr)  |
| <b>C</b>   | Moderately high run-off potential shallow soils and soils containing considerable clay and colloids through less than those of group (2.5-12.5 mm/hr)                                |
| <b>D</b>   | High run-off potential includes mostly clay of high swelling percent, but this group also includes some shallow soils with nearly impermeable sub horizons near surface (<2.5 mm/hr) |

|                |  |
|----------------|--|
| <b>AMC I</b>   | Preceding 5- day rain <12mm (dormant season)<br><36 mm (growing season)      |
| <b>AMC II</b>  | Preceding 5- day rain 12-28 mm (dormant season)<br>36-53 mm (growing season) |
| <b>AMC III</b> | Preceding 5- day rain >28mm (dormant season)<br>>53 mm (growing season)      |

**NRCS CN TABLE**

| S1 No. | Landuse    | Trestment/practice     | Hudrologic condition | Hydrologic soil group |    |     |    |
|--------|------------|------------------------|----------------------|-----------------------|----|-----|----|
|        |            |                        |                      | A                     | B  | C   | D  |
| 1      | Cultivated | Straight row           | .....                | 76                    | 86 | 90  | 93 |
|        |            | Contoured              | Poor                 | 70                    | 79 | 84  | 88 |
|        |            |                        | Good                 | 65                    | 75 | 82  | 86 |
|        |            | Contoured and terraced | Poor                 | 66                    | 74 | 80  | 82 |
|        |            |                        | Good                 | 62                    | 71 | 77  | 81 |
|        |            | Bunded                 | Poor                 | 67                    | 75 | 81  | 83 |
|        |            |                        | Good                 | 59                    | 69 | 769 | 79 |
|        |            | Paddy (rice)           | .....                | 95                    | 95 | 5   | 95 |

|   |                                   |                           |       |    |    |    |    |
|---|-----------------------------------|---------------------------|-------|----|----|----|----|
| 2 | Orchards                          | With under stony cover    | ..... | 39 | 53 | 67 | 71 |
|   |                                   | Without under stony cover | ..... | 41 | 55 | 69 | 73 |
| 3 | Forest                            | Dense                     | ....  | 26 | 40 | 58 | 61 |
|   |                                   | Open                      |       | 28 | 44 | 60 | 64 |
|   |                                   | Shrubs                    |       | 33 | 47 | 64 | 67 |
| 4 | Pasture                           | .....                     | Poor  | 68 | 79 | 86 | 89 |
|   |                                   |                           | Fair  | 49 | 69 | 79 | 84 |
|   |                                   |                           | Good  | 39 | 61 | 74 | 80 |
| 5 | Wasted Land                       | .....                     | ....  | 71 | 80 | 85 | 88 |
| 6 | Hard Surface                      | .....                     | ....  | 77 | 86 | 91 | 93 |
| 7 | Paved with curbs and storm sewers |                           |       | 98 | 98 | 98 | 98 |
| 8 | Gravel                            |                           |       | 76 | 85 | 89 | 91 |
| 9 | Dirt                              |                           |       | 72 | 82 | 87 | 89 |

Based on the estimated runoff the pond size must be designed, the pond size lesser than or equal to estimated runoff volume from the pond catchment area.

#### iv. Disposal of excavated material

Proper disposal with prolong useful life of the pond, improve its appearance and facilitate its maintenance and establishment of vegetation. The excavated material should be placed in a manner, that its weight will not endanger the stability of the pond, side slopes and the rainfall will not wash the material back into the pond. A berm with a width equal to depth of pond may be adapted.

#### v. Construction

The pond and waste areas should first be cleared of all vegetation. The limb of excavation and soil placement areas should be demarcated and excavated by step method using manual labour. Excavation and the placement of the excavated material are the principal items of work required in the construction of this type of pond. Experiences on water harvesting in dugout-cum-embankment type of pond in hilly region of North East India clearly indicate the feasibility of harvesting runoff from watersheds to an extent of 38% of monsoon rainfall.



Contribution of subsurface flow from upper slopes accounts for 82-90% of the annual into the water harvesting pond located in the lower reaches and only 10-18% comes from direct interception of rainfall and collection of surface runoff. Stored water is used for crop, livestock and fish production (Satapathy, 1996 & 2000).

### Plastic lining of ponds

Construction of small water harvesting structures in the lower reaches of micro-watersheds to store runoff and intercepted base flow for utilizing the stored water for pisciculture or to recycle back for life saving irrigation provides ample scope for water resources development in the NE Hills at a relatively low cost. This type of pond generally have high rate of seepage and percolation and cannot hold water during the crucial dry season. Two small ponds with storage capacity of 0.3 ham (AE pond) and 1.0 ham (FSRP pond) were created in the ICAR Research Farm at Barapani (Meghalaya). The pond were subsequently lined with LDPE Agri Film of 250 micron and covered with 30 cm soil on the bed as well as sides. The effect of lining and hydrological behaviour of ponds was studied. The maximum percolation rate through the AE pond under unlined condition was to be tune of  $0.040 \text{ m}^3/\text{m}^2$  wetted perimeter/day. The percolation rate has remarkably reduced to  $0.0029 \text{ m}^3/\text{m}^2$  wetted perimeter/day after lining pf the pond with Agri Film, showing average reduction of about 93% in the seepage loss (Rao and Satapathy 2005). Storage hydrographs of the pond after and before lining clearly shows the increase in water saving efficiency of the pond after lining in terms of both quantity and duration of storage

### Estimation of volume of a pond

The volume of excavation required can be estimated with sufficient accuracy by use of Primordial Formula.

$$V = \frac{A + AB + C}{6} \times D$$

Where V = Volume of excavation ( $\text{m}^3$ )

B = area of excavation at the ground surface ( $\text{m}^2$ )

C = area of the excavation at the bottom of pond ( $\text{m}^2$ ) ; and

D = average depth of the pond (m).

**Example – 3:** Compute the volume of excavation required to construct an excavated pond with an average depth (D) of 4.0m, a bottom width (W) of 12m, and a bottom length (L) of 30m the side slopes adopted are 2:1.

**Solution:** The volume of excavation required.

$$V = \frac{A + AB + C}{6} \times D$$

$$\text{Top length} = 30 + (4 \times 2) \times 2 = 46\text{m}$$

$$\text{Top width} = 12 + (4 \times 2) \times 2 = 28\text{ m}$$

$$A = 46\text{ m} \times 28\text{ m} = 1288\text{m}^2$$

$$\text{Mid-length} = 30 + (2 \times 2) \times 2 = 38\text{m}^2$$

$$\text{Mid-width} = 12 + (2 \times 2) \times 2 = 20\text{m}^2$$

$$4B = (38\text{ m} \times 20\text{ m}) \times 4 = 3040\text{ m}^2$$

$$C = 12\text{ m} \times 30\text{ m} = 360\text{ m}^2$$

$$A + 4B + C = 4688\text{ m}^2$$

$$V = \frac{4688}{6} \times 4 = 3124\text{ m}^3 \text{ or } 0.3124\text{ ha m}$$

**EXAMPLE:** - Determine the volume of earthwork for the pond of following size.

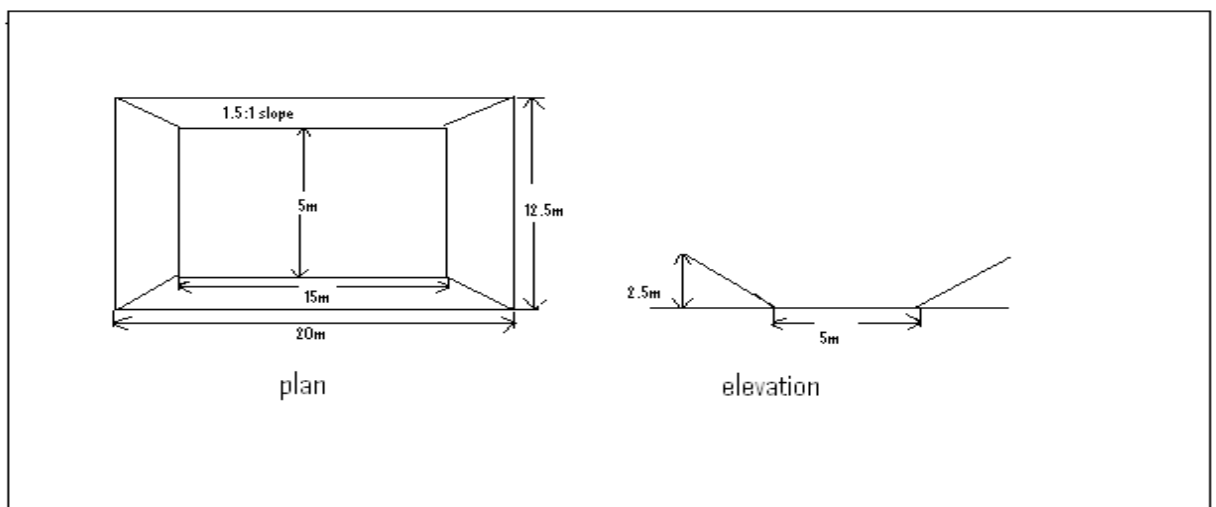

Top dimensions = 20m x 12.5m

Bottom dimension = 15m x 5m

Depth = 2.5m

Side slope = 1.5:1

Solution-

Volume of earth work =  $\frac{1}{2}$  (top dimension + bottom dimension) x depth

$$= \frac{1}{2}((20 \times 12.5) + (15 \times 5)) \times 2.5$$

$$= 390.62 \text{ m}^3$$

### Design of Farm Pond

Catchment area = 10 ha

Mean annual rainfall = 500 mm

Runoff = 10% of 500 = 50 mm

50mm from 10 ha =  $\frac{50}{1000} \times 10 \times 10000$

= 5000  $\text{m}^3$  = Expected volume of water

75% of probability 5000 =  $\frac{75}{100} \times 5000 = 3750 \text{ cum}$  or 3800 cum = Design Volume of water.

Side slope of the farm pond can be assumed 1: 5 : 1

$$b = \left\{ \sqrt{\frac{3V - d^3 z^2}{3d}} \right\} - dz$$

b = Bottom width

V = Volume = 3800

Z = Side slope = 1.5

d = Depth = 3 m

$$b = \left\{ \sqrt{\frac{3 \times 3800 - 3^3 \times 1.5^2}{3 \times 3}} \right\} - 3 \times 1.5$$

$$b = 35.5 - 4.5 = 31\text{m}$$

$$\text{Top width} = B = b + 2 d z$$

$$= 31 + 2 \times 3 \times 1.5 = 40 \text{ m}$$

## Ground Water Recharging Techniques for Drought Proofing of Watersheds

*Bhupendra Singh Naik*

*Pr. Scientist (SWCE), ICAR-Indian Institute of Soil and Water Conservation,  
Research Centre, Ballari, Karnataka*

### Introduction

Ground Water recharge is a process by which excess surface water is directed into the ground either by spreading on the surface, by using recharge wells or by altering natural conditions to increase infiltration to replenish an aquifer. Under this process, groundwater reservoir is augmented at a rate exceeding the augmentation rate under natural conditions of replenishment. Low rainfall, high water demand, more dependence and over-exploitation of groundwater for agriculture has resulted in continuous depletion of groundwater and shortage of water availability. The need of the hour is to go for groundwater recharge by artificial means to augment the natural infiltration of precipitation or surface water into underground formations. Artificial recharge refers to the movement of water through man-made systems from the surface of the earth to underground water-bearing strata where it may be stored for future use. This is also called planned recharge to store water underground in times of water surplus to meet demand in times of shortage. Planning of artificial recharge of groundwater depends on local topographical, geological and soil conditions; the quantity and quality of water available for recharge; and the technological-economical viability and social acceptability. Various aspects and techniques used for groundwater recharge by artificial means are discussed here.

### Why artificial recharge of ground water is needed

Availability of ground water varies considerably from place to place as the amount of percolation varies greatly from region to region and within the same region from place to place depending upon the amount and pattern of rainfall (i.e. number and duration of rainy days, rainfall amount and intensity), characteristics of soils and rocks (i.e. porosity, cracks and loose joints in rocks etc.), the nature of terrain (i.e. hills, plateaus, plains, valleys etc.), and other climatic factors like temperature and humidity. In most low rainfall areas, people mostly have to depend largely on ground water for agriculture and domestic use due to non-availability of sufficient utilizable surface water. Close spacing of bore wells and excessive ground water pumping has resulted in alarming lowering of the ground water levels and



depletion of aquifers. Population growth leads to high water demand both by households and agriculture. Rapid urbanization results in high water demand by the dense population living in cities which is causing much stress on groundwater and surface water resources, and it has drastically reduced open lands for natural recharge. Climate change and rising temperature (climate change) has also significant impacts on surface and ground water resources. In hard rock areas there are large variations in ground water availability even from village to village. In order to improve the ground water situation it is necessary to artificially recharge the depleted ground water aquifers. Various cost-effective techniques are available which can be practiced using locally available materials and manpower.

### **Studies required for planning artificial recharge**

For planning artificial recharge, the scientific studies i.e. hydro-meteorological studies, hydro geological studies and geophysical studies are to be carried out to understand the various local factors.

#### **Hydro-meteorological studies**

These studies are undertaken to understand the rainfall pattern and evaporation losses and thereby to determine the amount of water that would be available from a given catchment and the size of storages to be built.

#### **Hydro-geological studies**

A detailed hydro-geological study of the project area and also the regional picture of hydro-geological setting is necessary to know precisely the promising locations for recharge and the type of structures to be built for the purpose.

#### **Geophysical studies**

These studies are expensive and time consuming and require high levels of skill and sophisticated equipment. These are, therefore, economically viable for large ground water development projects and are not suitable for small artificial recharge schemes at local/village level. The main purpose of applying geophysical methods for the selection of appropriate site for artificial recharge studies.

### **Identification of areas for artificial recharge**

The artificial recharge projects are site specific and even the replication of the techniques from similar areas are to be based on the local hydro-geological and hydrological

situations. The following criteria are to be considered for identifying suitable areas for planning artificial recharge. Preferably a micro-watershed should be selected for the recharge purpose.

- Areas with declining ground water levels due to over-exploitation
- Desaturation of the aquifer i.e. dry/low yields of water in wells and hand pumps
- Inadequate availability of water from wells and hand pumps during summer
- Availability of poor quality ground water and absence of alternative source of water.

**Sources of water for recharge**

For planning artificial recharge, the various potential sources of water to be identified and assessed as mentioned below.

- Precipitation (rainfall) over the demarcated area
- Large roof areas from where rainwater can be collected and diverted for recharge
- Canals from large reservoirs from which water can be made available for recharge
- Natural streams from which surplus water can be diverted for recharge, without violating the rights of other users
- Properly treated municipal and industrial wastewaters. This water should be used only after ascertaining its quality

**Artificial recharge techniques**

Many techniques are available for recharging ground water but it varies with varied hydro-geological situations. The artificial recharge techniques can be broadly classified into two broad groups (i) Direct methods, and (ii) Indirect methods.

| (i) Direct methods   | (ii) Indirect Methods   |
|--|---|
| (a) Surface spreading techniques <ul style="list-style-type: none"> <li>• Flooding</li> <li>• Ditches and furrows</li> <li>• Recharge Basins</li> <li>• Run-off Conservation Structures</li> <li>• Stream-channel Modification</li> <li>• Surface Irrigation</li> </ul> (b) Sub-Surface Techniques <ul style="list-style-type: none"> <li>• Injection wells</li> <li>• Gravity-Head Recharge Wells</li> <li>• Connector Wells</li> <li>• Recharge pits</li> <li>• Recharge Shafts</li> </ul> | (a) Induced Recharge <ul style="list-style-type: none"> <li>• Pumping Well</li> <li>• Collector Wells</li> <li>• Infiltration Gallery</li> </ul> (b) Aquifer Modification <ul style="list-style-type: none"> <li>• Bore Blasting</li> <li>• Hydro-Fracturing</li> </ul> |

## Direct methods

### (a) Surface spreading techniques

Areas with gently sloping land without gullies or ridges are most suited for surface-water spreading techniques. These methods are suitable where large area of basin is available and aquifers are unconfined without impervious layer above it. The rate of infiltration depends on nature of top soil if soil is sandy the infiltration will be higher than those of silty soil.

### Flooding

The technique of flooding is very useful in selected areas where a favourable hydro-geological situation exists for recharging the unconfined aquifer by spreading the surplus surface-water from canals / streams over large area for sufficiently long period so that it recharges the groundwater body. This technique can be used for gently sloping land with slope around 1 to 3 percentage points without gullies and ridges.

### Ditches and Furrows

In areas with irregular topography, shallow, flat-bottomed and closely spaced ditches and furrows provide maximum water contact area for recharging water from the source stream or canal. This technique requires less soil preparation than the recharge basin technique and is less sensitive to silting.

### Recharge Basins

This is the most common method for artificial recharge. Artificial recharge basins are either excavated or enclosed by dykes or levees. They are commonly built parallel to ephemeral or intermittent stream-channels in series. The size of basin may depend upon the topography area, in flatter area will have large basin. The water contact area in this method is quite high which typically ranges from 75 to 90 percentage points of the total recharge area. This method is applicable in alluvial area as well as hard rock formation.

### Run-off conservation structures

Gully plugs, bench terracing, contour bunding/ trenching, percolation tanks etc. are constructed for conserving runoff. Gully plugs are the smallest run-off conservation structures built across small gullies and streams by using local stones, earth and weathered rock, brushwood, and other such local materials. Bench terracing is done for bringing terraced land under cultivation and it helps in soil conservation and holding run-off water for longer duration giving rise to increased infiltration recharge. Contour bunding/ trenching involve a watershed management practice so as to build up soil moisture storages. This technique is generally adopted in areas receiving low rainfall. In this method, the monsoon

run-off is impounded by putting barriers on the sloping ground all along contours of equal elevation. Percolation tanks are small tanks artificially created surface-water bodies submerging a highly permeable land area so that the surface run-off is made to percolate and recharge the groundwater storage.

### **Stream-channel Modification**

The natural drainage channel can be modified with a view to increase the infiltration by detaining stream flow by constructing check dam/ nala bund and increasing the stream-bed area in contact with water. The water stored in this structure is mostly confined to stream course and height is normally 2m.

### **Surface Irrigation**

If additional source of water is available, surface irrigation should be given priority as it gives a dual benefit of augmenting groundwater resources and crop growth.

#### **(b) Sub-Surface Techniques**

In this method the structure lies below the surface and recharges ground water directly. The important structure commonly use are Injection wells, recharge wells, recharge pits /shafts, dug wells etc. The injection wells are similar to a tube well and here water is pumped in for recharge. This technique is suitable for augmenting the groundwater storage of deeper aquifer by pumping in treated surface water. Recharge wells are constructed for effecting recharge by gravity inflow. Bore wells and dug wells used for pumping may also be alternatively used as recharge wells, whenever source of water becomes available. Connector wells are special type of recharge wells where, due to difference in potentiometer head in different aquifers, water can be made to flow from one aquifer to other without any pumping. The aquifer horizons having higher heads start recharging aquifer having lower heads. Recharge pits are structures excavated of variable dimensions that are sufficiently deep to penetrate less permeable strata and artificial recharge of phreatic aquifer from surface-water sources. Recharge Shafts are used in case of poorly permeable strata overlie the water table aquifer located deep below land surface. A recharge shaft is similar to a recharge pit but much smaller in cross-section

#### **Indirect Methods**

##### **(a) Induced Recharge**

It is an indirect method of artificial recharge involving pumping from aquifer hydraulically connected with surface water, to induce recharge to the groundwater reservoir.

### **Pumping Wells**

Induced recharge system is installed near perennial streams that are hydraulically connected to an aquifer through the permeable rock material of the stream-channel.

### **Collector Wells**

For obtaining very large water supplies from river-bed, lake-bed deposits or waterlogged areas, collector wells are constructed.

### **Infiltration Gallery**

Infiltration galleries are horizontal perforated or porous structure (pipe) used for tapping groundwater reservoir below river-bed strata.

### **Aquifer Modification**

These techniques modify the aquifer characteristics to increase its capacity to store and transmit water. These techniques are artificial yield augmentation measures rather than artificial recharge measures.

### **Bore Blasting**

These techniques are suited to hard crystalline and consolidated strata where the aquifer displays limited yield that dwindles or dries in winter or summer months.

### **Hydro-Fracturing**

In many cases, blasting has given indifferent results. Hydro-fracturing is a recent technique that is used to improve secondary porosity in hard rock strata. Hydro-fracturing is a process whereby hydraulic pressure is applied to an isolated zone of bore wells to initiate and propagate fractures and extend existing fractures to improve the yield of the bore well.

### **Advantages of groundwater recharge**

The major potential advantages of artificial recharge are as follows:

- To enhance the groundwater yield in depleted aquifer due to urbanization.
- Conservation and storage of excess surface water for future requirements.
- To enhance the quality of existing groundwater through dilution.
- To remove the bacteriological and other impurities from sewage and waste water by natural filtration, so that water is suitable for re-use.

### **Conclusion**

Artificial recharge give the reduction of runoff, increased availability of ground water in summer, increase in irrigation, revival of springs and improvement in ground water quality. Though ground water recharge scheme either naturally or artificially may not be the final answer, but they do call for the community effort and create the spirit of cooperation needed to subsequently manage sustainably ground water as a community resource.

---

## Soil & Water Conservation Techniques for Arable and non Arable lands

*B. Krishna Rao*

*Head & Pr. Sci. (SWCE) ICAR-Indian Institute of Soil & Water Conservation,  
Research Centre, Ballari, Karnataka.*

---

### Introduction

The suitability of a given type of conservation measure in an area depends upon slope, rainfall (amount and distribution), soil type and depth, water holding capacity, location of impervious layer, agricultural practices, power/equipments used and economics. Lands having less than 2% slopes do not require any of the structural measures in general. Lands up to 10% slope may require narrow or broad based terraces. The broad based terraces are useful when land holdings are large and machinery is used for farming operations. It is doubtful if narrow based terracing i.e. blinding be of any practical use in lands having slopes more than 6%. In high rainfall areas, such land slopes will require uneconomically closer spacings resulting in more loss of area. It is difficult to achieve uniformity in blinding practice on lands steeper than 4% and in any case steeper than 6%. For lands with slopes above 10% and up to 33%, bench terracing is an effective measure as it breaks the length and also reduces the degree of slope. It, however, restricts farming operations, is expensive and significant area is lost out of cultivation. From the point of view of efficient water management, graded terraces are to be adopted in areas where rainfall is more or for areas where inspite of moderate rainfall, runoff disposal is a problem. Level terraces are for drier tracts with scanty or erratic rainfall where moisture conservation is of prime importance. Area lost out of cultivation is highest in bench terracing while under blinding, 5-10% area is lost which can be put to alternate land uses.

### Importance of conservation structures

- Increasing the time of concentration and thereby allowing more runoff water to be absorbed and stored in the soil profile due to enhance infiltration opportunity time.
- Intercepting a long slope into several short ones, so as to maintain less than the critical velocity for the runoff water.
- Protection against damage owing to excessive runoff.
- Reducing the steepness (degree) of slope.
- Terracing/bunding is the most effective and widely used practice for controlling or preventing erosion on agricultural lands in different agro-ecological regions

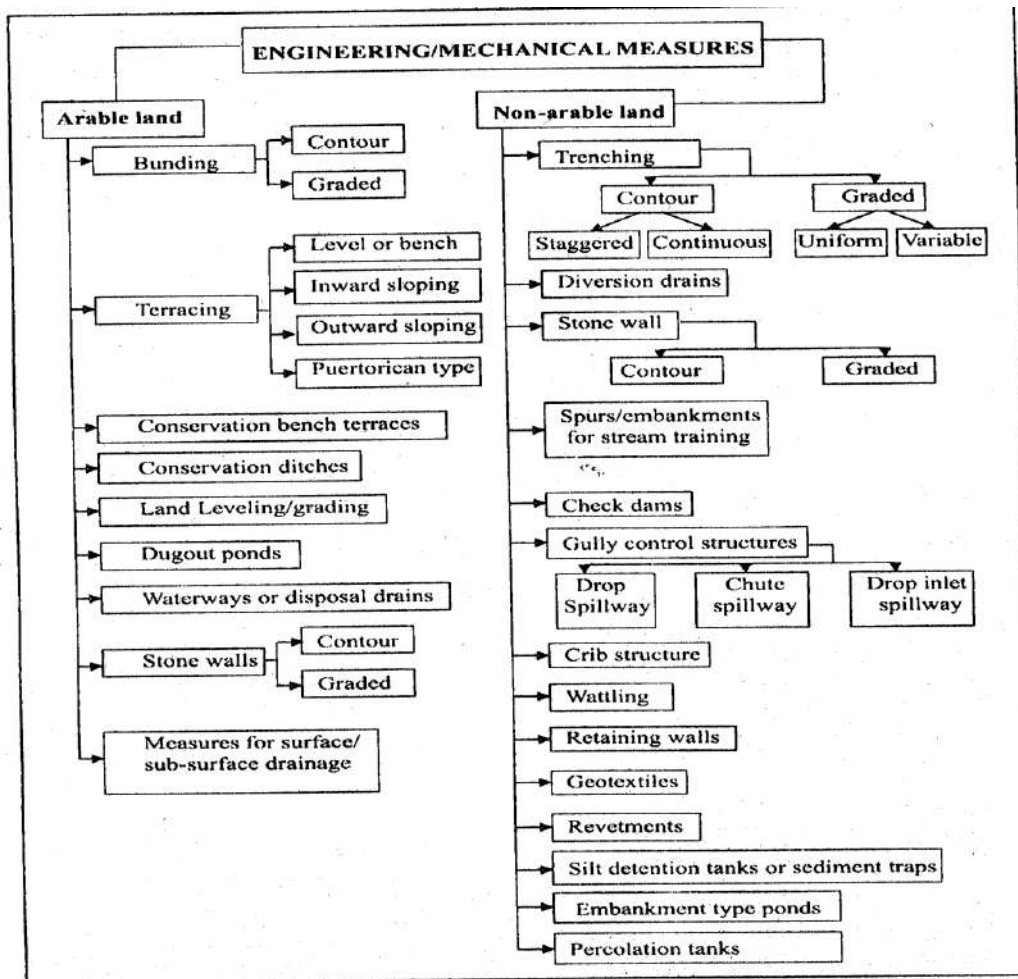

## Conservation measures for arable lands

### Bundling

- Contour bunds are constructed along approximate contours (with permissible deviations) for moisture conservation.
- Side bunds are constructed at extreme ends of the contour bunds running along the slope.
- Lateral bunds are constructed along the slope in between two side bunds in order to prevent concentration of water along one side and to break the length of contour bund into convenient bits.
- Supplemental bunds are constructed between two contour bunds so as to limit a horizontal spacing to the maximum required.
- Marginal bunds are constructed along boundaries of the micro-watersheds, road margins, river or stream margins, gully margins etc.
- Graded bunds are constructed along a predetermined grade (uniform/variable) for safe disposal of excess runoff.
- Broad based bunds are adopted for soil and moisture conservation in large land holdings where farming is done by machines.

Shoulder bunds are constructed on the outer end of bench terraces to contain runoff and soil loss usually in outwardly sloping terraces.

### Contour bunding

#### Function

For slopes ranging between 2-6 % with scanty or erratic rainfall (less than 800 mm annually), contour bunding is practiced to intercept the runoff flowing down the slope by an embankment with either open or closed ends to conserve moisture as well as reduce erosion.

#### Soils

Contour bunds can be adapted on most types of relatively permeable soils that are alluvial, red, laterite, brown, shallow, medium black except the clayey deep black soils.

#### Specifications

The planners need the following information

- *How far the bunds should be spaced?*
- *What should be the deviation freedom to go higher and lower than the contour bunds for getting better alignment in undulating areas?*
- *What should be the cross section?*

### Graded bunding

#### Functions

The function of graded bunds consist of constructing wide and relatively shallow channels across the slope, very near the contour ridges are and at suitable vertical intervals. These terraces act primarily at drainage channel for inducing and regulating the excess runoff water and draining it with a mild and non-erosive velocity.

#### Suitability

These bunds are adopted in areas receiving rainfall exceeding 750mm particularly in soils having infiltration rate less than 8mm per hour.

#### Factors to be considered

- Location of the most desirable terrace outlets
- As a safety factor, a terrace system comprising of short terraces and several outlets located in natural water courses.
- Strengthened natural waterways have the advantage of terrace outlets.
- If vegetation alone is not capable of providing protection to conduct concentrated water down the slope, structures need to be constructed to encounter sudden drops, excessive velocities, and poor grass cover.



## Specifications

It includes vertical interval (V.I.), channel grade and cross section.

## Peripheral bunds

The bund which is constructed at periphery of the field, where the chances of formation of the gully, elongation of gully head, rills and ravines are known as Peripheral bund. These prevents erosion, purtrher elongation of gully head etc.

## Field bunds

These bunds are constructed between field across the slope to prevent soil erosion and formation of rills. This bund prevents soil and nutrient losses.

| Erosion control measures                               | Suitability    |                                      |                             |   |
|--|----------------|--------------------------------------|-----------------------------|---|
|  | Land slope (%) | Soil depth                           | Rainfall (mm)               | Crops or land use   |
| 1  | 2              | 3                                    | 4                           | 5   |
| <b>1. Bunding</b>                                      |                |                                      |                             |   |
| a) Contour bunding                                     | < 6            | Shallow to deep, permeable           | < 800                       | Small millets, pulses, oil seeds, coarse grain, root crops                              |
| b) Graded bunding                                      | < 6            | -do-                                 | 800-1500                    | -do- and wheat vegetables   |
| c) Contour terrace* wall (stone pitched contour bunds) | 16 to 33       | Impermeable soils                    | <800                        | -do-  |
|  |                | Good and very high infiltration rate | > 1000                      | Root crops, vegetables etc.   |
| <b>2. Bench terracing</b>                              |                |                                      |                             |   |
| a) Level   | < 33           | Medium to deep                       | < 2500-3000 (High rainfall) | i) Paddy, ii) Small millets, pulses, oil seed, coarse grain, vegetables in low rainfall |
| b) Inward sloping                                      | < 33           | -do-                                 | -do-                        | Potato, other vegetables, maize, oats etc.  |
| c) Outward sloping                                     | < 33           | Shallow                              | < 1200                      | Small millets, oats, barley etc.  |
| <b>3. Puertorican Terraces</b>                         |                | Medium to deep                       | < 1500                      | Root crops, vegetables, oats, small millets etc.  |
| a) With vegetative barrier                             | < 12           |                                      |                             |   |
| b) With mechanical barriers                            |                |                                      |                             |   |
| <b>4. Trenching</b>                                    |                |                                      |                             |   |
| a) Contour trenches                                    |                |                                      |                             |   |
| i) Continuous  | < 8            | Medium to deep                       | < 1500                      | Tapioca, ginger, turmeric and similar annual crops                                      |
| ii) Staggered  | < 8            | Shallow to medium                    | < 800                       | Papaya, banana  |
|  | < 33           | Medium to deep but well drained      | < 2000                      | Tea, coffee, arecanut, coconut, black pepper, nutmeg, cinnamon, papaya, banana etc.     |
| b) Graded trenches                                     | < 33           | Medium to deep soil but well drained | 2000-3000                   | -do-  |
| <b>5. Conservation bench terracing</b>                 | < 10           | -do-                                 | < 1200-2000                 | Paddy on lower portion and maize crop on sloping portion                                |
| <b>6. Zingg terracing</b>                              | <10            | Shallow to medium                    | < 1200-2000                 | Paddy on lower portion and cover crop on sloping portion                                |
| <b>7. Stone wall</b>                                   |                |                                      |                             |   |
| a) Contour   | < 33           | Shallow to medium                    | < 1500                      | Annual crops like tea, coffee, spices etc.  |
| b) Graded  | < 33           | -do-                                 | 1500-2500                   | -do-  |

### **Bench terraces**

Bench terraces are flat beds constructed across the hill slopes along the contours with half cutting and half filling. They serve as barriers to break the slope length and also reduce the degree of slope thereby eliminating the all erosion hazards. Experiences show that, construction of dry bench terraces even up to 40 to 50 % slope in NE region are feasible (Prasad, *et al* 1987 & Satapathy, 2000). The vertical interval of such terraces should not be more than 1.0 m. Such measures can be adopted where soil depth is more than 1 m. Bench terraces can also be developed with vertical stone walling and are in use by the farmers of the region. Side bunds on the outer edge of the terrace should be provided to prevent slipping down of soil and overtopping of excess runoff from the terraces. To maintain top soils in terraces, the construction should start from the foot hills. There are three types of terraces mostly using. These are

#### **Level bench terraces**

Benches are almost leveled to ensure uniform depth of impounding water. This type of bench terrace is used for paddy cultivation.

#### **Inwardly slopping bench terraces**

Benches are made inward slopping to drain runoff as quickly as possible. These types of bench terraces are preferred for cultivation of tuber crops such as potato, ginger, turmeric, and sweet potato which are susceptible to water logging.

#### **Outwardly slopping bench terraces**

Benches are made outward slopping and these are used in low rainfall areas.

#### **Puertorican or California type of terraces**

These terraces are formed by gradual conversion of land between two barriers into terrace by natural leveling process. Mechanical barriers (bunds) or vegetative barriers (grasses or shrubs) or combination of both, are laid along the contours. Due to ploughing and interculture operations soil is eroded and gets deposited at the barriers. Thus, in due course terraces are formed.

#### **Half-moon terraces**

The half-moon terraces are constructed for planting and maintaining saplings of fruit and fodder trees in horticulture and agroforestry land use system. The construction of this type of

terrace is made by earth cutting in half-moon shape to create circular level bed having 1 to 1.5 m diameter.

The mechanical/engineering soil and water conservation measures are effective in controlling runoff and soil loss and enhance the productivity of rainfed lands. These measures have been implementing by various Governmental schemes to control soil erosion in arable lands. But cost of construction of these measures is very high and farmers are not able to implement these measures without support of any schemes/programmes. The vegetative and agronomic measures control the soil erosion and conserve the rainwater some extent and these are cost effective and easily implemented by the farmers.

### Vegetative Measures for Soil & Water Conservation in arable lands

The various vegetative measures for reducing the sediments and nutrients losses are vegetative filter Strips, Riparian Forest Buffer, Conservation Cover, Contour Buffer Strips, Alley Cropping, and Grassed Waterways. Live-bunds or vegetative barriers are the alternative biological measures, which have been shown to effectively conserve soil and water by moderating the surface runoff and allowing them increased infiltration time.

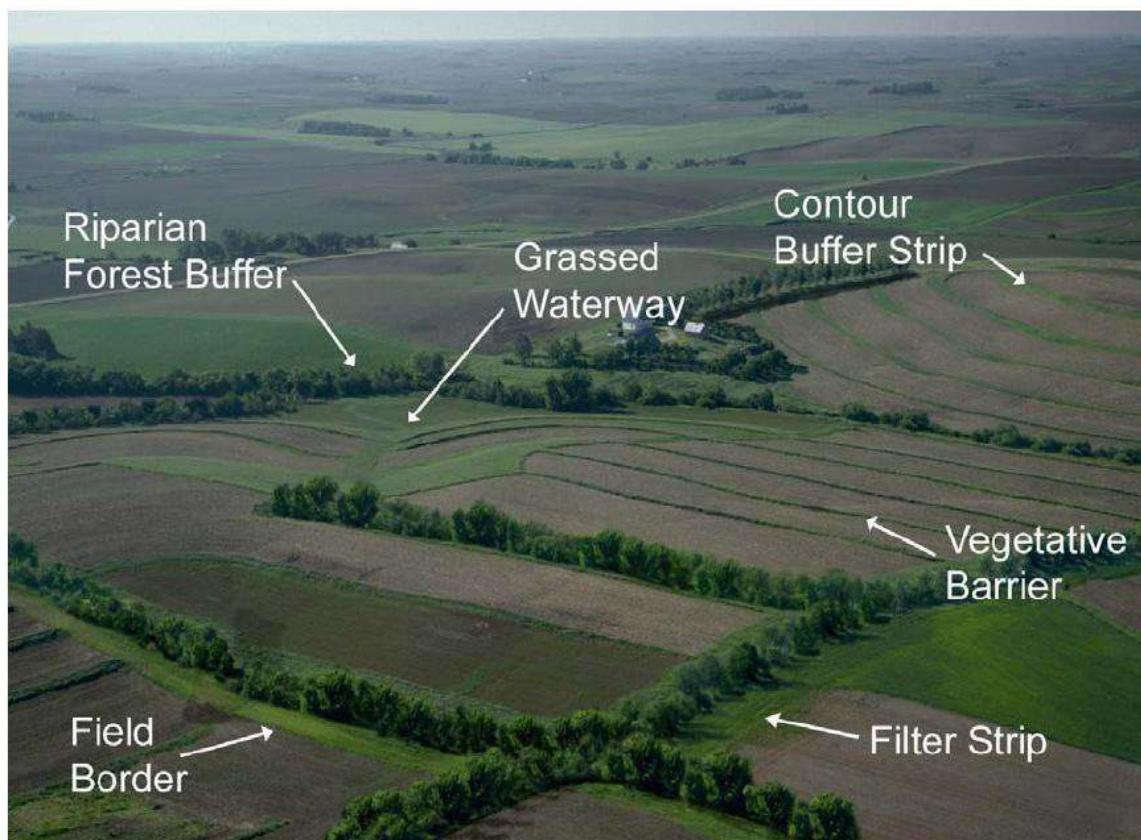

**Figure 1: Vegetative measures (photo courtesy of USDA-NRCS)**

### Vegetative filter strips

A Vegetative filter strip is the dense, planted vegetation (typically grass of short height up to 45 cm) across the slope to remove sediment and other pollutants from runoff coming directly from the crop land. Vegetative filter strips are only intended to provide runoff treatment and are therefore situated between the table land and a surface water collection system, pond, tanks, reservoirs, rivers etc.



Vegetative filter strips (VFS)

can able to capture soil and nutrients from runoff coming from agricultural lands. The VFS as sheet flow reducing the chances of rills and gully formation and captures sediments along the path and allowing sediment free runoff to gully bed. A vegetative filter strip is a defined area of vegetation next to a waterway designed to remove pollutants and sediment from runoff water via particle settling, water infiltration, and nutrient uptake. A filter strip's purpose is to filter and capture nutrients, sediment and pathogens in surface runoff coming from grazing areas (manure, cropland, etc.) before the contaminated runoff reaches any surface water. A filter strip's most important function is to help keep fecal coliform bacteria and other pathogens contained in livestock manure out of streams, ditches and seasonal drainages. Filter strips can be managed to produce feed and reduce pollution. Pastures and haylands that are already established next to sensitive areas can make excellent filter strips

### Vegetative barriers

The grass barriers are narrow strips (approximately 1.2 m wide) of tall, erect, stiff-stemmed, native perennial grasses planted on the contours to reduce the sediment yield, retard and disperse the runoff and facilitate benching of the slopes. Whereas, the vegetative filter-strips are typically much wider (more than 5 m) established between field borders and water ways. Vegetative barriers are considered relatively cheaper, eco-friendly and pro-



farmer. Their usefulness is increasingly realized either for supplementing or substituting earthen bunds.

### Grassed waterways

A grassed waterway is a vegetated channel that carries runoff at a nonerosive velocity to a stable outlet. Grassed waterways can be enhanced by including filter strips to filter runoff and

to trap sediment outside of the waterway. Vegetation in the channel should be lay down to convey water while vegetation in the filter strips should be tall and stiff to avoid submergence and to



filter sediment from runoff. If properly sized and constructed, grassed waterways safely transport water down natural draws through fields. Waterways also provide outlet channels for constructed terrace systems, contour cropping layouts and diversion channels. Grassed waterways are a good solution to the erosion caused by concentrated water flows when the watershed area generating the runoff water is relatively large. Grassed waterways are broad, shallow and typically saucer-shaped channels designed to move surface water across farmland without causing soil erosion. The vegetative cover in the waterway slows the water flow and protects the channel surface from the eroding forces of runoff water. Left alone, runoff and snowmelt water will drain toward a field's natural draws or drainage ways. It is in these areas that grassed waterways are often established.

### Agronomical Measures for Soil & Water Conservation

Soil conservation is a preservation technique, in which deterioration of soil and its losses are eliminated or minimized by using it within its capabilities and applying conservation techniques for protection as well as improvement of soil. In soil and water conservation, the agronomical measure is a more economical, long lasting and effective technique. Agronomic conservation measures function by reducing the impact of raindrops through interception and thus reducing soil erosion. They also increase infiltration rates and thereby reduce surface runoff. Widely used agronomic measures for water erosion control are given below.

### Contour Cropping

Contour Cropping is a conservation farming method that is used on slopes to control soil losses due to water erosion. Contour cropping involves planting crops across the slope instead of up and down the slope. Use of contour cropping protects the valuable top soil by reducing the velocity of runoff water and inducing more infiltration. On long and smooth slope, contour cropping is more effective as the velocity of flow is high under such situation and contour cropping shortens the slope length to reduce the flow velocity. Contour cropping is most effective on slopes between 2 and 10 percent.



### Strip Cropping

Strip cropping is the practice of growing strip of crops having poor potential for erosion control, such as root crop (intertilled crops), cereals, etc., alternated with strips of crops having good potentials for erosion control, such as fodder crops, grasses, etc., which are close growing crops. Strip cropping is a more intensive farming practice than contour farming. The farming practices that are included in this type of farming are contour strip farming, cover cropping, farming with conservation tillage and suitable crop rotation.



A crop rotation with a combination of intertilled and close growing crops, farmed on contours, provides food, fodder and conserves soil moisture. Close growing crops act as barriers to flow and reduce the runoff velocity generated from the strips of intertilled crops, and eventually reduce soil erosion. Strip cropping is laid out by using the following three methods:

## Mulching

Mulches are used to minimize rain splash, reduce evaporation, control weeds, reduce temperature of soil in hot climates, and moderate the temperature to a level conducive to microbial activity. Mulches help in breaking the energy of raindrops, prevent splash and dissipation of soil structure, obstruct the flow of runoff to reduce their velocity and prevent sheet and rill erosion (Fig.). They also help in improving the infiltration capacity by maintaining a conducive soil structure at the top surface of land.



Mulching of cropped field

## Agronomic Measures

### Conservation/contour furrow

A conservation furrow at 45 days after sowing can be opened with bullock drawn implements in between crop rows to conserve the rainwater and reduce the soil and nutrient losses from the crop fields..Contour-furrow irrigation can save irrigation water, reduce erosion, and mean better crops on sloping fields. You waste little water by surface runoff or by over irrigation at the upper end of the furrows. In comparison with down -slope irrigation, water in contour furrows moves more slowly across the field and, therefore, does not erode or wash the soil. You get a more even distribution of water over the field, making good growing conditions for all of the plants. This pays off in better yields and in higher quality products. Irrigation water flowing down sloping fields is wasting our basic soil and water resources at a very serious rate

### Ridge-furrow system

The ridge-furrow system with alternate ridges and furrows is one of the innovative water-saving technologies which aim to drastically increase the precipitation use efficiency in rain-

fed farming systems of arid and semi-arid areas. Ridges and furrows are made with bullock drawn plough across the slope in June at the onset of monsoon. The width of furrow is 45 cm and height is 20 cm. The ridge and furrow system performed better in medium as well as high rainfall areas. In high rainfall regions, this system serves as drainage as well as moisture conservation measures.



### Broad bed and furrow system

Broad bed and furrow system involves preparation of broad bed of 90-120 cm, furrow of 45 cm and sowing of crop at row spacing of 30 cm. In medium rainfall regions, the broad bed and furrow (BBF) system significantly increased the crop yields, particularly the soyabean yields in Vertisols of Maharashtra and Madhya Pradesh upto 83% over the farmer's practice.



During high rainfall events BFB drains the runoff through furrows, while also acts storage which moisture availability during scarcity period

### Conservation Measures for Non Arable Lands

Four land capability classes viz. V, VI, VII, VIII have one or more limitations of the slope, erosion, stoniness, rockiness, shallow soils, wetness, flooding etc. which make them usually unsuited for crop production. Their use is mainly limited to pasture, forest, wild life & recreation. These lands are generally confined to upper reaches of watershed and have an undulating topography and are foci for the soil erosion. In lands with steep slopes and subjected to the soil erosion, vegetative cover do not established. Due to lack of vegetative cover soil erosion is accelerated transporting large amount of sediment in to streams below.



Uncontrolled runoff from the sloping lands also causes extensive damage in lower reaches of the watersheds. In order to prevent the degradation of these lands, vegetative and mechanical measures are employed together and are complimentary to each other. Mechanical measures act like the foundation of building whereas the vegetative measures act like super structure which helps in improving the productivity of non arable lands. These lands have a great potential for producing fodder, fuel, minor forest produce, fruits and low quality timber. These lands having some water conservation measures. The practices such as contour trenching, gradonies, installation of temporary and permanent gully control structure, construction of sediment retention structures and retaining walls, reclamation of ravine lands, improvement and management of grass lands and rehabilitation of mined lands can be adopted for soil and water conservation measure in non arable areas of watershed.

### Contour trenches

Is any form of depression or micro pit or trench constructed over the land surface. In order to prevent soil erosion and to absorb rainwater in non arable lands, trenches constructed along the contours (called contour trenches) on hill slopes above 15% with vegetative supports for forestry and horticulture land uses. Generally trenches may be dug with a cross section of 0.30 m x 0.30 m at 1 to 2 m vertical interval (Thansanga, 1997). For proper drainage of excessive runoff, they may be connected with longitudinal drains and drop pits. They are called continuous when there is no break in length and maximum length can be 100 to 200 m long across the slope depending on the width of the field. However, when these are laid scattered with maximum length of 2 to 4 m, they are called staggered contour trench. The trenches may be trapezoidal or rectangular in cross section but flatter upstream side slopes are preferred in order to minimize the risk of scouring by incoming runoff.

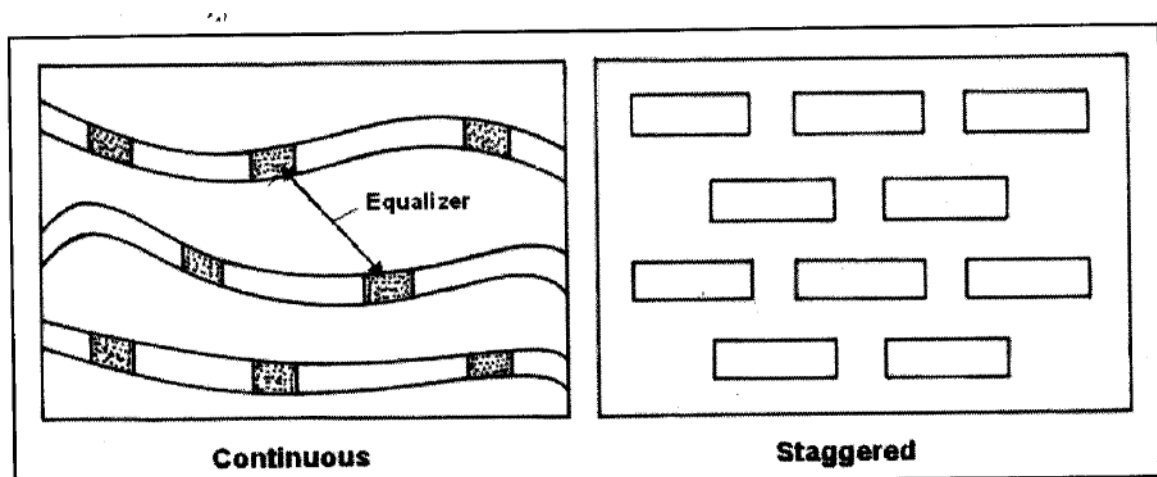



One hectare of land continuous contour trenches is constructed in Vejalpur/Rampura watershed.

The length of trench is 100 m (field width is 100 m). The depth is 0.3 m, width is 0.3 m. the spacing of the trenches is 10 m. Determine the volume of watershed in 1 hectare of land.

$$\begin{aligned} \text{❖ Length of watershed} &= 10,000 \text{ m}^2 / 100 \text{ m} \\ &= 100 \text{ m} \end{aligned}$$

$$\text{No of Trenches} = 100 \text{ m} / 10 \text{ m} = 10$$

$$\text{Volume of one trench} = 0.3 \times 0.3 \times 100 = 9 \text{ m}^3.$$

$$\text{Volume of total trenches} = 9 \times 10 = 90 \text{ m}^3.$$

### Grassed waterways

The main function of grassed waterways is to drain out excess runoff from the field at non-erosive velocity. It helps protect land against rill and gully erosion. Turfs or sod of perennial grasses which are drought resistant, erosion resistant and submergence resistant should be established to protect the channel section against any kind of erosion because of the concentrated flow. The trapezoidal section of grassed waterways is more appropriate because it is more stable and has larger capacity as compared to other cross sections. Moreover, trapezoidal shape will assume parabolic shape in due course.

### Diversion drains

Diversion drains are sometimes called simply diversions. They are the channels constructed across the slope for the purpose of intercepting runoff and conveying the same to a safe outlet. Diversion drains are located above the agricultural lands at lower reaches of hill slope. Diversion drains are also constructed at the gully heads or at the upstream of banded or terraced areas to intercept the surface runoff to avoid any damage from concentrated flow.

---

## Water Harvesting Check dams for Climate Resilient Agriculture in Rainfed Regions

*B. Krishna Rao*

*Pr. Scientist & Head., ICAR-Indian Institute of Soil & Water Conservation,  
Research Centre, Ballari, Karnataka*

---

### Introduction

The rainfed regions of India are characterized by aberrant behaviour of monsoon rainfall, eroded and degraded soils with water and nutrient deficiencies, declining ground water table and poor resource base of the farmers. The major constraint is low and unstable yields in rainfed areas with large yield gap. In addition to these, climate variability including extreme weather events resulting from global climate change poses serious threat to rainfed agriculture. In rainfed regions, rainwater is the main source of water for agriculture but its use efficiency for crop production is low and varies from 30-45%. In monsoon dependent country like India, the rainfall is received in 100 days in 100 hours; therefore, there is a great need of storage of surplus runoff. The farm pond technology is one of the best technologies for climate resilient agriculture and is gaining of popularity, however, it is not feasible for marginal farmers due to area lost for cultivation and cost/unit of water harvested. In locations, where natural streams are available, the check dams can be an alternative for runoff harvesting and recycling to cope with climatic aberrations such as mid seasonal and terminal droughts and floods. Check dams are constructed to store rain water and silt on the upstream side. Depending upon size of nala, its slope, watershed area and severity of the problem, suitable type of check dam can be selected. Temporary check dams made of locally available material like brushwood, log wood and planks are used in small gullies, mostly in the upper reaches where runoff is less. Semi permanent check dams made of loose boulder, and/or dry stone packing are recommended in small to medium gullies. Gabion check dams are preferred in medium gullies in the middle reaches. Permanent gully control structures/water harvesting structures are used in medium to large gullies carrying more runoff especially in lower reaches. The effect of check dams on groundwater recharge, water availability, production, productivity, livelihood improvement were reported by several scholars (Wani *et.al.*, 2007, Sharda *et al.*,2005 , Joshi *et. al.*, 2005, Kumar *et. al.*, 2004; Dhyani *et. al.*, 2016).

### Temporary check dams

For stabilization of gullies through vegetation is a difficult task. Temporary mechanical measures are adopted to prevent washing away of the plantation by large volume of run-off

that provides to establish the vegetation. Vegetations once established will be able to take care of the gully. Followings are some such mechanical measures / structures; a) Check Dams; - (i) Temporary check dams, (ii) Brush dam, (iii) Semi permanent check dams. b) Loose Rock Dam c) Log Wood Dam. Vegetative live check dams are constructed in upper reaches of the catchments or watershed. The grasses or baboo type of species can be used as live or vegetative check.



Bamboo plantation as live check dams in degraded Mahi Ravines of Gujarat

### **Earthen check dams**

Earthen check dams can be defined as small earthen embankments across gullies or streams to reduce the runoff velocity, stabilization of gullies and store the runoff water. The size of the gully plug/checkdam depends on width length and bed slope of the gully, anticipated runoff and proposed plantations in the gully. The height of the gully plug/earthen checkdam usually kept as 0.9 to 1.5 m, top width 1 m for small gullies and 2 m for medium gullies, side slopes 1:1, and length of the gully plug will be kept as equal to the channel width. The spacing depends upon the gradient of the channel bed. Usually for 3 % slope every 30 m distance gully plug can be constructed. These can be constructed at upper reaches of the catchment or watershed. The benefits of these check dams will be stabilization of gully beds and banks, deposition of sediments and nutrients, water storage thereby enhancing soil moisture and better plant growth and reduce the runoff and soil loss by 80%.

### **Bori bund checkdam**

Bori bunds is a type of embankment constructed across the gullies using polythene bags (empty cement or fertilizer bags) filled with the locally available sand or soil for blocking active and erosion-prone first-order streams. It is an effective method to slow down the speed of flowing water of the stream in any area. Usually where earthen gully plugs is not able to control the runoff flow these structures can be constructed. The size of the bori bund depends on width, length and bed slope of the gully, anticipated runoff and proposed plantations in the

gully. The height of the bori bund usually kept as 0.9 to 1.5 m, top width 0.6 m, side slopes 1:1, and length of the gully plug will be kept as equal to the channel width. The spacing depends upon the gradient of the channel bed. Usually for 3 % slope every 30 m distance one bori bund can be constructed. For uniform distribution of soil moisture to the plantations, minimum spacing and minimum height can be maintained. Medium Gullies and deep gullies with complete sandy soils. The locations, where earthen gully plugs is not able to control the runoff flow (Rao et al., 2012). The benefits will be stabilization of gully beds and banks, deposition of sediments and nutrients, water storage thereby enhancing soil moisture and better plant growth and reduced the runoff and soil loss by 80%.



Earthen and bori bunds/sand bag checkdams

### **Permanent gully control/water harvesting structures**

Permanent Gully Control Structures are necessary where vegetative or temporary structures are not adequate. Permanent Structures such as masonry check dams, flumes or earth dams supplemented by vegetations are provided to convey the run-off over critical portion of the gully. Principal types of permanent structures are drop spillways, drop inlet spillways and chute spillways.

#### **Drop spillway**

The drop spill way is a weir structure. Flow passes through the weir opening, drops to an approximately level apron or stilling basin and the passes to the downstream channel Drop spillway may be constructed of reinforced concrete, plain concrete, rock masonry and concrete blocks with or without reinforcing or gabions. The spillway is an efficient structure for controlling relatively low heads, normally up to 3.0 meters.

#### **Drop inlet spillways**

A drop inlet spillway is a closed conduit that carries water under pressure from above an embankment to a lower elevation. The usual function of a drop inlet spillway is to convey a

portion of the runoff through or under an embankment without erosion. It is a very efficient structure for controlling relatively high gully heads usually above 3.0m.

### **Chute spillways**

A chute spillway is an open channel with a steep slope, in which flow is carried at a supercritical velocity. It consists of an inlet, vertical curve section, steep sloped channel and a out let. Reinforced concrete is widely used to construct chute spillways and adopted particularly to high overfall gullies, detention dams to reduce the required capacity.

### **Brick/stone masonry check dams**

In locations, where natural streams are available in lower reaches of the watershed, the brick/stone masonry check dams can be an alternative for runoff harvesting and recycling to cope with climatic aberrations such as mid seasonal and terminal droughts and floods. The construction of brick stone masonry structures involves high cost without any scheme/ programme the adoptability by these structures is low. The rubber and plastic check dams are the cost effective and easy for construction. These will reduce the construction difficulties. These are easily adopted by watershed management schemes for rainwater harvesting and water management for a long period without incurring any substantial maintenance cost.



Brick, Stone masonry checkdams



Water harvesting checkdam

## Conclusion

In monsoon dependent country like India, the rainfall is received in 100 days in 100 hours; therefore, there is a great need of storage of surplus runoff. The farm pond technology is one of the best technologies for climate resilient agriculture and is gaining of popularity, however, it is not feasible for marginal farmers due to area lost for cultivation and cost/unit of water harvested. In locations, where natural streams are available, the check dams can be an alternative for runoff harvesting and recycling to cope with climatic aberrations such as mid seasonal and terminal droughts and floods.

## References

- Joshi, P.K., Jha, A.K., Wani, S.P., Joshi, L. and Shiyani, R.L. 2005. Meta-analysis to assess impact of watershed program and people's participation. Research Report 8, Comprehensive assessment of watershed management in agriculture. International Crops Research Institute for the Semi-Arid Tropics and Asian Development Bank. 21 pp.
- Kumar, V., Kurothe, R.S., Singh, H.B., Tiwari, S.P., Pande, V.C., Bagdi G.L. and Sena, D.R. 2004. Participatory watershed management for sustainable development in antisar watershed, Kheda, Gujarat under Integrated Wastelands Development Programme, Ministry of Rural Development, Govt. of India, New Delhi. Central Soil & Water Conservation Research & Training Institute, Research Centre, Vasad, 388 306.
- Sharda, V.N., Samra, J.S. and Dogra, P. 2005. Participatory watershed management programs for sustainable development: experiences from IWDP. Indian Journal of Soil Conservation
- Wani, S.P., Sreedevi, T.K., Rockstrom, J. and Ramakrishna, Y.S. 2009 Rain-fed agriculture - past trend and future prospects. In Rainfed agriculture: Unlocking the Potential. Comprehensive Assessment of Water Management in Agriculture Series (S.P Wani., J. Rockström and T. Oweis, Eds),. CAB International, Wallingford, UK. pp. 1-35.

---

## Recent Advances (GIS and Remote Sensing) in Watershed Planning and Implementation

*M Prabhavathi*

*Senior Scientist (Soil Science), ICAR- Indian Institute of Soil and Water Conservation,  
Research Centre, Ballari, Karnataka- 583 104*

---

### Introduction

Water resources development and its availability is one of the crucial factors for sustainable development of nation. Though, water is omnipresent and abundant since oceans cover 70 percent surface of the earth, but usable fresh water available on land is just about 2.7 percent. In essence merely 1 percent of water on earth is available in usable form. The population explosion has also increased the demand of water resources for various purposes. The rapid evolution in satellite remote sensing and Geographical Information System (GIS) has made possible the development of new techniques for facilitating the mapping of degraded / eroded lands. Remote sensing data provides accurate timely and real time information on various aspects such as size and shape of the watershed, land use/land cover, physiography, soil distribution, drainage characteristics etc. During the last few decades remote sensing and Geographical Information System (GIS) approaches has gained importance in soil loss estimation, generating overlays and making site-specific decisions. Multi-spectral remotely sensed satellite data plays a vital role in the generation of the overlays. Remote sensing data is being extensively used in watershed studies especially for making site specific decisions.

Remote sensing and GIS: Remote sensing technology deals the requirements of reliability and speed, and is an ideal tool for generating spatial information which is pre-requisite for planned and balanced development at watershed level. The Geographical Information Systems (GIS) technology provides suitable alternatives for efficient management of large databases. Integration of Remote sensing data and GIS technologies has proved to be an efficient tool for water resources development and management projects as well as for watershed characterization and prioritization. An appropriate technology developed for particular regions cannot be used as such for other areas for physiographic, environmental, technical and socio-economic reasons. The water resources development technologies are not based on annual rainfall only, but terrain, soil type, drainage, land use/ land cover and there variability in space and time too plays an important role in determining the suitable sites for water conservation. Thus, it is generally accepted that sustainable land and water



management must be approached with the application of advanced technologies (remote sensing and GIS) and watershed as the basic management unit.

## Watershed

It is an area that drains all the incoming rainwater as surface or subsurface runoff into a water body/reservoir is termed as a watershed. A watershed encompasses a complex of soils, landforms, land uses, and vegetation within the topographic boundary or water divide.

## Morphometric analysis

The runoff potential depends on the surface characteristics (geometry, network, texture, and relief aspects) of a catchment. Thus, hydrologic characterization becomes important through studying the morphometry of a watershed. Hydrologic characterization is the study of the features which affect the various components of a hydrologic cycle within the watershed boundary. Moreover, the hydrologic characterization is a way forward for prioritizing watersheds even in the absence of a soil map, which is possible through morphometric analysis by finding out the several watershed characteristics. Implementation of conservation measures is mainly dependent on the morphometry of a particular watershed. The quantification and scientific study of configuration of the Earth's surface, its shape, and landform dimensions is termed as morphometric analysis. It is one of the key techniques to monitor and assess watershed response to variations in climate, drainage physiognomies.

**Table:** Average size and size ranges for each Hydrological Units

| S. No. | Category of Hydrologic Units | Example of Code | Size Range (ha)        | Average Size (ha) |
|--------|------------------------------|-----------------|------------------------|-------------------|
| 1.     | Water Resource Region        | 2               | 270,00,000-1130,00,000 | 5,50,00,000       |
| 2.     | Basins                       | A               | 30,00,000-300,00,000   | 95,00,000         |
| 3.     | Catchments                   | 1               | 10,00,000-50,00,000    | 30,00,000         |
| 4.     | Subcatchments                | A               | 200,000-10,00,000      | 7,00,000          |
| 5.     | Watersheds                   | 2               | 20,000-300,000         | 1,00,000          |
| 6.     | Subwatersheds                | a               | 5,000-9,000            | 7,000             |
| 7.     | Microwatersheds              | 2               | 500-1,500              | 1,000             |

## Factors that determine the geomorphologic characteristics of a watershed

**Precipitation:** The greatest factor controlling stream flow is the amount of precipitation that is in the form of rain or snow. Hence, the change in the amount of precipitation will affect the characteristics of watershed.

**Infiltration:** Water gets infiltrate enters much deeper, recharging groundwater aquifers and it generally travels long distances or remains in storage for long periods before returning to the surface.

**Soil characteristics:** The soil characteristics also determine the watershed as clayey and rocky soils absorb less water at a slower rate than sandy soils and soil already saturated from previous rainfall cannot absorb water and result in surface runoff.

**Land cover:** It has a great impact on infiltration and rainfall runoff affecting the watershed where impervious surfaces leads to flooding of areas.

**Slope of the land:** The angle of the surface determines the amount of runoff where water falling on steeply-sloped land runs off more quickly than water falling on flat land.

### **Geospatial technology in watershed studies**

Geospatial technology is highly efficient for drainage pattern analysis, investigating spatial variability in the drainage features, prioritization of sub-watersheds, modeling water resources and managing floods. It is time efficient and capable to manage complex issues, as well as big database and retrieval. Thus, the increasing use of remote sensing and GIS technologies in geomorphologic mapping has enhanced the efficacy of landform dissection, quantification, and organization.

### **Assessing watershed conditions through various modeling**

Through the use of computer aided software and availability of huge resources of digital data, mapping of watershed have proven tremendously much easier for a researcher in the field of GIS technology. The use of RS and GIS in the application of watershed management has changed from operational support (e.g., inventory management and descriptive mapping) to prescriptive modeling and tactical or strategic decision support system. The application has enabled mapping giving accurate information through many multi resolution data that has helped in delineation of ridge line, stream flow, erosion prone areas etc.

### **Some of the features of remote sensing and GIS in the study of watershed are as follows**

- Watershed characterization and assessment
- Management planning
- Application of watershed modeling (soil, geology, land cover, rainfall, ground water etc.)
- Identification of soil erosion vulnerable area

## Steps involved in Morphometric analysis

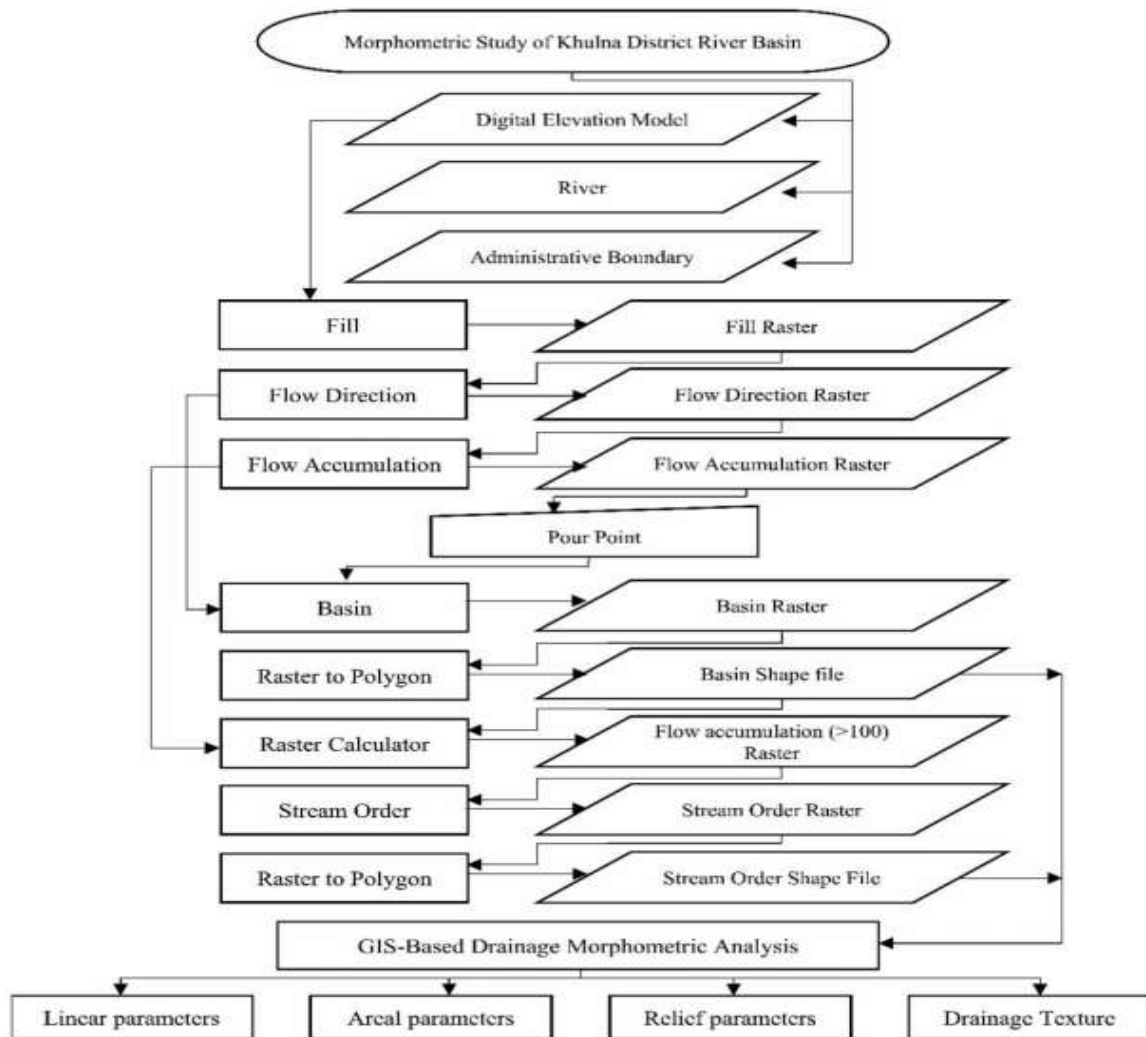

Source: Rahman *et al.* (2023)

## Data and approaches

The entire morphometric analysis was carried out within the south-western basin, which was created using the ArcGIS 10.3.1 watershed delineation approach based on SRTM DEM. For this study, SRTM DEMs data with a 30-meter spatial resolution were downloaded from the ‘OpenTopography’ website (<https://opentopography.org>). This platform now has updated data that was produced with the aid of auxiliary DEMs and enhanced interpolation methods. As a result, this edition marks a significant improvement in the data accuracy of DEMs. The software process along with associated approaches is shown in Figure 2. Parameters of the basin such as its area, perimeter, length, and width, as well as the number and length of streams in various stream orders, are automatically extracted using ArcGIS tools. Again,

stream length ratio, bifurcation ratio, rho coefficient, stream frequency, drainage density, drainage texture, circulatory ratio, elongation ratio, form factor, etc., are derived from those parameters using several pre-established. The Digital Terrain Model (DTM)-based approach also produces flow direction and flow accumulation

### Indicators for sediment yield calculation

| S.N. | Parameters       | Source                           | Criteria adopted for weighted values   |
|------|------------------|----------------------------------|--|
| 1    | Barren/bare land | Derived from LANDSAT™            | It is the direct effect of human intervention in ecologically sensitive places. The higher the weightage value, the more barren terrain is covered.  |
| 2    | Dense forest     | Derived from LANDSAT™            | Because vegetation is such an essential natural resource, and canals serve as an environmental indicator, a region's dense forest cover is an important indicator of human effect. The lower the weightage value, the more dense forest coverage there is. |
| 3    | Soil texture     | Kumar and Sharma (2005)          | In terms of calculating soil loss, soil texture is a critical factor. The sandy loam texture has been given a high rating.   |
| 4    | Topography       | SOI Top sheets on 1:50,000 scale | Slope is always significant since it has a direct impact on the amount of rainfall that falls on the soil. It varies depending on the slope's steepness and length. The greater the elevation, the greater the weight.                                     |

### Stream network analysis

The study of a stream network involves evaluation of the linear parameters of a catchment. It includes computation of stream order, length of a stream, mean stream length, stream length ratio, bifurcation ratio, basin length, length of overland flow, watershed perimeter, wandering ratio, fitness ratio, and sinuosity indices.

**Stream order (U):** Stream ordering can be defined as a measure of stream positioning in the hierarchy of a watershed drainage system (Leopold et al. 1964). For the quantitative study of a river basin, categorization of stream orders is the first step to be performed. Horton (1932) introduced the idea of stream ordering, which is widely used in classifying the streams in a basin. Horton (1945) was the first to promote stream ordering in a basin, which was expedited ahead by Strahler (1952) with some changes. According to Strahler (1964), the number of streams slowly declines with increased stream ordering. The lower order streams (below third order) are generally seasonal, whereas the streams having an order of three or more always carry a substantial amount of water. The existence of higher numbers of streams in a basin indicates that the area still suffers from erosion, while lesser numbers indicate an established topography (Pande & Moharir 2017).

**Stream number (Nu):** Stream number is the total number of streams per stream order and can be calculated in GIS (Horton 1945). It has a direct relationship with the size of the watershed and channel measurements. It is dependent upon geology, slope, soil type, vegetation, and climate (mainly rainfall) in a catchment. In general, Nu decreases in

geometric progression with increasing stream order. In other words, the stream order increases with a decrease in Nu at each successive stream order (Horton 1945).

**Stream length (Lu):** It is one of the important hydrological characters which helps in understanding the runoff characteristics in a watershed. The total length of the stream segments decreases with the increase in the stream order. Generally, the total stream length is the maximum for first order streams and reduces by a rise in the stream order.

**Drainage network:** Horton (1932) introduced this term or ratio (Rb), which is associated with the branching pattern of a drainage network (Schumm 1956). It is the ratio of the number of streams of order U and the number of streams of the next order (U+1) (Schumm 1956; Strahler 1964). It depends on the physiography, slope, and climatic conditions of the watershed. It is a dimensionless property (ranging from 3.0 to 5.0). The higher Rb value indicates more soil erosion in relation to the severe overland flow and lower recharge potential in the watersheds. An elongated basin has a high Rb value, whereas a circular basin has a low Rb value.

$$L_u = 1.312 \times A_w^{0.568}$$

$$L_u = 1.4 \times A_w^{0.6}$$

Bifurcation ratio (Rb)

**Drainage Density (Dd):** Dd is the indicator of drainage efficiency of the watershed. It is the measure of the total length of the stream segment of all orders per unit area. It is affected by factors which control the characteristic length of the stream like resistance to weathering, permeability of rock formation, climate, vegetation etc. In general, low value of Dd is observed in regions underlain by highly resistant permeable material with vegetative cover and low relief.

**Stream frequency (Fs):** Stream frequency/channel frequency (Fs) is the total number of stream segments of all orders per unit area (Horton, 1932). In general, low stream frequency indicates maximum area of sub watershed is covered with forest and high frequency indicates maximum area is covered with agricultural land.

**Drainage texture (T):** Drainage texture can be expressed as a ratio between the total number of stream segments and the basin perimeter (Horton 1945; Smith 1950). Smith (1950) has classified drainage texture into five different texture i.e, very coarse (<2), coarse (2-4),

moderate (4-6), fine (5-8) and very fine (>8). Finer the drainage texture, more run off is expected.

**Form factor (Rf):** It is defined as ratio of basin area to square of the basin length (Horton, 1932). The basins with high Rf will have high peak flows of shorter duration, whereas, elongated sub watershed with low form factors have lower peak flow of longer duration. Flood flows of elongated basins are easier to manage than the circular basin. Smaller the value of form factor, more elongated will be the basin which indicates a flatter peak of flow for longer duration.

**Circularity ratio (Rc):** It is the ratio of area of basin to the area of circle having the same circumference as the perimeter of the basin (Miller, 1953). It is influenced by the length and frequency of streams, geological structures, land use/land cover, climate, relief and slope of the basin.

**Elongation ratio (Re):** It is the ratio between the diameter of the circle of the same area as the drainage basin and the maximum length of the basin. A circular basin is more efficient in runoff discharge than an elongated basin. The Re values can be grouped into three categories, namely circular (>0.9), oval (0.8-0.9), less elongated (<0.7). Higher values of linear parameters also indicate higher erosion. Smaller values of shape parameters indicate higher soil erosion.

**Spatial database generation:** Drainage network, contour map, surface water bodies and village location maps can be generated from the Survey of India toposheets on 1:50,000 scale. The watershed boundary of the any catchment can be delineated using hydrology tool within GIS environment considering topographical parameters derived from Digital Elevation Model (SRTM DEM) and Drainage network. The Soil map of the study area can be obtained from the ICAR- NBSS & LUP, Nagpur. The cloud free digital data of Landsat 8-9 Imagery of 30m spatial resolution in seven spectral bands was downloaded from <http://glcfapp.umiacs.umd.edu:8080/esdi/index.jsp>. The ERDAS IMAGINE 8.6 software can be used for processing of the satellite data. With help of ground truth information land use / land cover classification of satellite data can be easily carried out under Arc GIS environment.

### **Morphometric Parameters**

For morphometric analysis, perimeter, maximum length, drainage map, numbers of streams of each order and watershed relief values are required. These inputs were computed using ARC-GIS software.

### **Prioritization of watershed through Morphometric analysis**

The variables derived from morphometric analysis are in the form of ratios and dimensionless numbers thus providing an effective comparison, regardless of scale. The quantitative morphometric parameters of each sub watersheds can be estimated independently for the prioritization purpose. The prioritization includes the bifurcation ratio, drainage density, stream frequency, texture ratio and three basin parameters i.e., form factor, circularity ratio and elongation ratio. The highest value of any first four parameters (i.e. bifurcation ratio, drainage density, stream frequency, texture ratio) among sub watersheds is given a rating of 1, the next highest values is given rating of 2, and so on. The lowest value is rated last in the series of numbers. For the shape parameters, the lowest value is given a rating of 1, the next lowest values is given rating of 2, and so on. After the rating has been done based on every single parameter, the rating values for every sub watershed are averaged to arrive at a compound value. Based on the average value of these parameters, the sub watershed having the least rating value is assigned the highest priority number of 1, the next highest values is assigned a priority number 2, and so on. The sub watershed that got highest value is assigned the last priority number.

### **Estimation of Soil Erosion Potential in the watersheds**

The RUSLE map can be prepared in the spatial domain using GIS, i.e., all RUSLE factors can be derived as raster (grid) geographic layers after processing the original data and then they are multiplied together for calculating the final risk map.

The methodology used was the implementation of the RUSLE in a raster GIS environment (or grid-based approach) using the formula:

$$A = RKLSCP$$

where, A = average annual soil loss in t ha<sup>-1</sup> yr<sup>-1</sup>; R = rainfall erosivity index for a given location; K = soil erodibility factor; L = slope length factor; S = slope steepness factor; C = cover and management factor; P = conservation or support practice factor.

| Erosion class | Soil Loss ( $t\ ha^{-1}\ yr^{-1}$ ) |
|---------------|-------------------------------------|
| Slight        | <5                                  |
| Moderate      | 5-10                                |
| High          | 10-20                               |
| Very High     | 20-40                               |
| Severe        | 40-80                               |
| Very severe   | >80                                 |

### Rainfall Erosivity (R) factor ( $MJ\ mm\ ha^{-1}\ h^{-1}\ yr^{-1}$ )

The rainfall erosivity (R) factor was derived using the relationship between rainfall erosivity index and annual/seasonal rainfall, developed by Ram Babu et al. (2004) with the data available from 123 meteorological observatories in India.

$$Y = 81.5 + 0.380X \quad (r = 0.90) \dots(1)$$

$$Y = 71.9 + 0.361X \quad (r = 0.91) \dots(2)$$

Whereas, Y is the average annual erosion index ( $t\ ha^{-1}\ cm^{-1}$ ) in equation (1) and average seasonal erosion index in equation (2)

### Soil Erodibility (K) factor

It can be estimated by an empirical equation developed by Wischmeier et al. (1971) and an attribute table was prepared for different soil types using the relation:

$$100K = 2.1 \times 10^{-4} (12\ OM) M^{1.14} + 3.25 (S2) + 2.5 (P3) \dots(3)$$

where, OM = organic matter (%), M = (% silt + % very fine sand) (100 - %clay), S = soil structural code, P = profile permeability class.

### K factors for different soil erodibility class

| Code | Soil erodibility | Description  | K factor |
|------|------------------|--|----------|
| 1    | Very low         | Soils with high to very high organic matter content and moderate to rapid permeability   | 0.07     |
| 2    | Low              | Except for sandy Entisols, these soils have moderate organic matter content and moderate permeability                                    | 0.17     |
| 3    | Moderate         | Generally slowly permeable soils with moderate organic matter content; the alluvial Entisols have low to moderate organic matter content | 0.27     |
| 4    | High             | Poorly structured top soils  | 0.37     |

**L, the slope-length factor**, is the ratio of soil loss from the field slope length to that from a 22.04 m of slope length under identical conditions.



**Slope steepness factor (S)**, is the ratio of soil loss from the field slope gradient to that from a 9% slope under otherwise identical conditions.

Digital elevation model (DEM) is developed based on Shuttle Radar Topography Mission (SRTM) data of 90 m resolution, which was available at <http://srtm.csi.cgiar.org/SELECTION/inputCoord.asp>. The slope gradient map and LS factor was generated using this DEM. The LS-factor was derived as described by Gitas et al. (2009) using the calculation of the S (slope steepness) and L (slope length) factors:

$$L = 1.4 (AS/22.13)^{0.4} \dots\dots\dots(4) \text{ and}$$

$$S = (\sin \beta / 0.0896)^{1.3} \dots\dots\dots(5)$$

Whereas, catchment area (m<sup>2</sup>) and β: slope angle in degrees

**or**

$$LS = ([Flow\ accumulation] \times cell\ size / 22.13)^n \times (Sin([slope] \times 0.01745) / 0.0896)^m \times 1.4$$

n=0.4 and m=1.4

**Crop Management Factor (C)**: It is the expected ratio of soil loss from a cropped land under specific condition to soil loss from clean tilled fallow on identical soil and slope under the same rainfall conditions.

$$C=1.02-1.21*NDVI$$

**Conservation Practice Factor (P)**: Conservation practice factor (P) is the ratio of soil loss with a specific support practice to the corresponding loss with up and down slope cultivation.

**Site selection criteria for soil and water conservation structures**

| Name of structure | Slope Category               | Land use                                 | Soil type | Drainage            | Catchment area |
|-------------------|------------------------------|--|-----------|---------------------|----------------|
| Check dams        | Nearly level to gentle slope | River stream (Near by agricultural land) | Fine loam | Upto 3 rd order     | Upto 25 ha     |
| Percolation tank  | Nearly level to very gentle  | Open land /Waste land                    | Clay loam | 2 nd and 3 rd order | >5 ha          |
| Nala bunds        | Nearly level to very steep   | Open land/Waste land                     | Loam      | Upto 3 rd order     | >20 ha         |

Spatial distribution of average soil loss factor

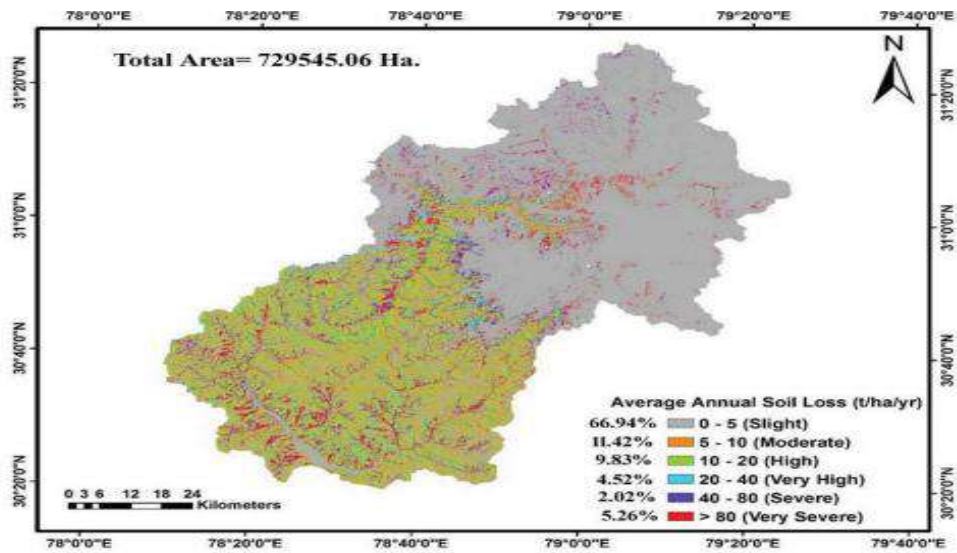
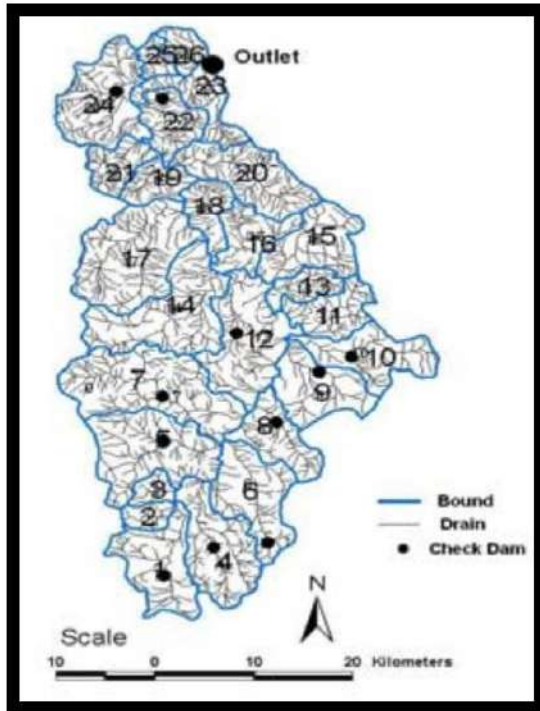
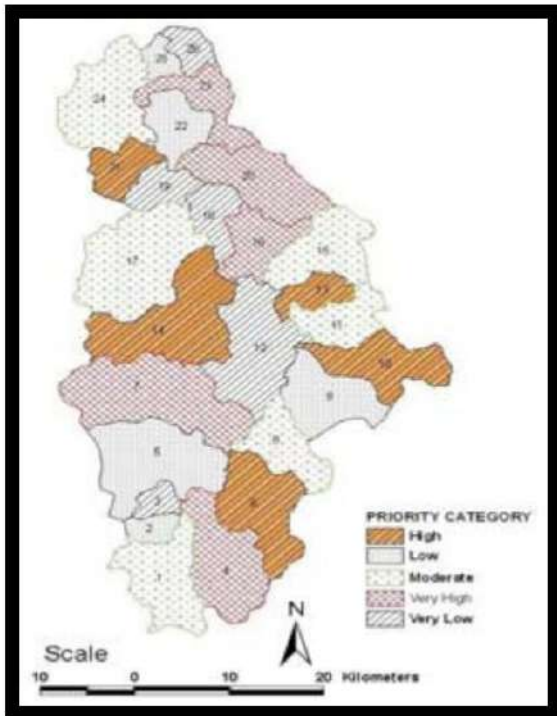

Ret watershed a) Prioritization of the sub watershed b) Location of suitable sites of check dam

Source: Pandey et al., (2011)

## References

- Horton, R.E (1945). Erosional development of streams and their drainage basins: hydrophysical approach to quantitative morphology. *Bull. Geol.Soc. Amer.*, 56: 275-370.
- Horton, R.E. (1932). Drainage basin characteristics. *Trans. Am. Geophys. Union*, 13: 350-361.
- Joy, Md.A.K., Upaul, S., Kaniz, F and Rezvi Amin, F.M.2023. Application of GIS and remote sensing in morphometric analysis of river basin at the South-western part of great Ganges delta, Bangladesh. *Hydrology Research*. Vol.54 (6): 739-755.
- Pandey, A., Behra, S., Pandey, R.P and R. P. Singh.2011. Application of GIS for Watershed Prioritization and Management: A Case Study. *International Journal of Environmental Science Development and Monitoring*. Vol. 2(1): p 25-42.
- Schumm, S.A. 1956. Evolution of drainage systems and slopes in badlands at Perth Amboy, New Jersey. *GSA Bulletin* 67(5), 597-646.
- Singh, D.V., Vishnoi, R.K., Routela, T.S and A.K.Badoni. 2021. Analytical Study of Sediment yield characteristics of Tehri Catchment in Upper Himalayas. In *ICOLD Symposium on Sustainable Development of Dams and River Basins*, 24-27th February, 2021, New Delhi.
- Strahler, A.N.1952. Hypsometric (area-altitude) analysis of erosional topography. *Geological Society of America Bulletin* 63, 1117-1142.
- Strahler, A.N.1964. Quantitative geomorphology of drainage basin and channel networks. In: *Handbook of Applied Hydrology*. McGraw Hill, New York, pp. 39-46.
- Wischmeier, W.H and Smith, D.D. (1978) Predicting rainfall erosion losses – A guide to conservation planning. *Agriculture Handbook*.

---

## **Indigenous & Local Knowledge (ILK) or Indigenous Technical Knowledge (ITK) on Soil and Water Conservation**

*Dr Prasanta Kumar Mishra*

*Former Director, ICAR-Indian Institute of Soil and Water Conservation, Dehradun.*

---

### **Introduction**

Soil and water are the basic resources and these must be conserved as carefully as possible. The pressure of increasing population neutralizes all efforts to raise the standard of living, while loss of fertility in the soil itself nullifies the value of any improvements made. This calls for more systematic resource conservation efforts. It is well known to every farmer that it is the top soil layer, which sustains agricultural production. Once this layer is lost or eroded, nothing can be done to replace it within a short period of time. Climate and hydrology, soil topography, soil surface conditions and their interactions are major factors affecting erosion-sedimentation processes. The semi-arid regions with few intense rainfall events and poor soil cover condition produce more sediment per unit area. But the man's intervention has disturbed the natural equilibrium and intensive and extensive agriculture has become a dominant factor in accelerating land degradation. The ever-increasing population pressure has brought intensive cultivation of land to the forefront through irrigated agriculture. No doubt these practices have resulted in a great increase in productivity, but they have resulted in large-scale water logging. Cultivable wastelands are increasing in the agricultural fields due to improper land management. The obvious remedy for this is to follow appropriate soil and moisture conservation practices along with integrated nutrient supply system for improvement of soil fertility as well as crop productivity on sustained basis. Soil and water conservation in any form is the only known way to protect the productive lands. In a predominantly agricultural country like India, where droughts and floods cause chronic food scarcity, adequate soil conservation programme, not only increases crop yield, it also prevents further deterioration of land. Methods to control surface runoff and soil associated erosion have been practiced in India from times immemorial. Traditional/local knowledge is gathered over a period of time and transferred from generation to generation. It is synonymous to local knowledge and is defined as "A sum total of knowledge based on acquired knowledge and experience of people in dealing with problems and typical situation in different walks of life". For the term indigenous technical knowledge

(ITK)/ or Indigenous and Local Knowledge (ILK), “local knowledge” and “Traditional knowledge” have been used in the literature interchangeably. It is the knowledge, which has been accumulated by the people over generations by observation, by experimentation and by handling on old peoples’ experiences and wisdom in any particular area of human behavior. Indigenous technical knowledge is the local knowledge that people have gained through inheritance from their ancestors. It is a people derived science and represents people’s creativity, innovations and skills. Indigenous technological knowledge pertains to various cultural norms, social roles or physical conditions. Such knowledge is not a static body of wisdom, but instead consists of dynamic insights and techniques, which are changed over time through experimentation and adoption to environmental and socio-economic changes. This knowledge has backgrounds of hundreds and sometimes thousands of years of adoption, while bearing odds and evens of the time. This knowledge is not possessed by only one sector of society, for example, in many cultures women and elders have passive insights into certain aspects of culture. Sometimes researchers have been unaware of such perceptiveness among rural people due to their biased focus on land-owning male farmers, neglecting other members of society. Traditional knowledge and practices have their own importance as they have stood the test of time and have proved to be efficacious to the local people. Some of these traditional practices are in the fields of agriculture – crop production, mixed farming, water harvesting, conservation of forage, combined production system, biodiversity conservation, forestry and domestic energy etc. Fortunately, we have many indigenous techniques for conserving natural resources. There is a need to enmesh these practices along with conventional soil and water conservation measures for promoting sustainable development of agriculture. It may not be out of place to mention that some of these ITKs/ILKs may need minor modifications in different watershed situations as well as socio-economic fabrics across the country. Inclusion of these ITKs would ensure sustainability of different eco-systems, befitting the man-animal-plant-land-water complex in each watershed. The documentation of ITKs on soil and water conservation will form a basis for formulating coordinated research programme for validation and refinement of the ITKs on soil and water conservation. Although farmers practice many indigenous technologies relating to soil and water conservation, there is a lack of documentation for identifying the constraints for possible refinements to make them Modern Technical Knowledge (MTK) with scientific validation.

In India, a detail study of Indigenous Technical Knowledge (ITK) on soil and water conservation in rainfed areas was taken up through a National Agricultural Technology Project (NATP) entitled “Documentation & Analysis of Indigenous Methods of *In-situ* Moisture Conservation and Runoff Management” at Central Research Institute for Dryland Agriculture (CRIDA) in early 2000.

### Methodology

In order to obtain the feedback of the farmers regarding soil and water conservation measures the survey using developed proforma (Table 1) was initiated in treated and untreated villages in different agro-ecological regions of India through the AICRPDA project centers.

**Table 1. Sample ITK Proforma**

|  |                   |       |
|--|-------------------|-------|
| 1. Title (Local name, if any)  |                   |       |
| 2. Purpose / Objective / Rationale   |                   |       |
| 3. Location – Village, Block / Mandal, Dist, State   |                   |       |
| 4. Agro-Ecology  | Agro-eco. Region: | Soil: |
|  | Rainfall (mm):    |       |
|  | Crops             |       |
| 5. Percentage of problematic area covered (Farmers having similar problems)  |                   |       |
| 6. Description <ul style="list-style-type: none"> <li>• Category of farmer (small / medium/big)</li> <li>• Individual / community basis</li> <li>• How the practice evolved</li> <li>• Since how long this ITK is in use</li> <li>• In case of crop planting &amp; gap filling method and time with seed rate</li> <li>• Maintenance</li> <li>• Farm implements used (if any)</li> <li>• Cost/ha (or cost/structure) &amp; labour involved</li> <li>• Methods of implementation / ITK specification</li> </ul> |                   |       |
| 7. Advantages  |                   |       |
| 8. Constraint (for adoption, implementation, maintenance, replication, etc.  |                   |       |
| 9. Improvement (for wider adoption, of the system etc.) or simplification Whether any external support needed  |                   |       |
| 10. Replicability / Feasibility (other places in India where this can be adopted)  |                   |       |
| 11. Photographs / slides / Map / Videograph  |                   |       |
| 12. Additional information   |                   |       |

## Documented ITKs

The ITKs were documented under following specific categories (Table 2).

**Table 2. A list of some documented ITKs on soil and water conservation measures under different categories**

| S. No | Categories  | Name of ITK   |
|-------|---|---|
| 1     | <b>Agronomic Measures</b>                                       | <ul style="list-style-type: none"> <li>i. Intercropping</li> <li>ii. Cultivation and sowing across the slope</li> <li>iii. Wider row spacing and deep interculturing</li> <li>iv. Mixed cropping</li> <li>v. Cover cropping</li> <li>vi. Criss –cross ploughing</li> <li>vii. Hoeing with local hoes</li> <li>viii. Set furrow cultivation</li> <li>ix. Application of Farm Yard Manure (FYM)</li> <li>x. Strip cropping</li> <li>xi. Green capping</li> <li>xii. Green manuring</li> <li>xiii. Pre-emergence soil stirring</li> <li>xiv. Ridge and furrow planting</li> </ul>  |
| 2     | <b>Tillage</b>  | <ul style="list-style-type: none"> <li>i. Conservation furrows with traditional plough</li> <li>ii. Deep ploughing</li> <li>iii. Summer ploughing/ Off-season tillage</li> <li>iv. Repeated tillage during monsoon season</li> </ul>  |
| 3     | <b>Bunding &amp; Terracing (Mech. &amp; Vegetative barrier)</b> | <ul style="list-style-type: none"> <li>i. Vegetative barrier</li> <li>ii. Stone bunding</li> <li>iii. Nala check with soil filled in cement bags</li> <li>iv. Compartmental bunding</li> <li>v. Peripheral bunding/ Field bunding</li> <li>vi. Ipomea as vegetative barrier</li> <li>vii. Conservation bench terrace</li> <li>viii. Loose stone surplus</li> <li>ix. Stabilization of field boundary bund with Vitex negundo</li> <li>x. Strengthening bunds by growing grasses</li> <li>xi. Bund farming of pulse crops in kharif under rainfed situation</li> <li>xii. Earthen bunds</li> <li>xiii. Stone-cum-earthen bunding</li> <li>xiv. Live bunding by raising Cactus</li> <li>xv. Grass Plantation on field boundaries (filter strip)</li> <li>xvi. Growing of Saccharum munja as vegetative barrier on field boundaries</li> </ul> |
| 4     | <b>Land Configuration</b>                                       | <ul style="list-style-type: none"> <li>i. Use of indigenous plough for formation of broad bed &amp; furrows</li> <li>ii. Furrow opening in standing crops local implement hoe (Dawara) for moisture conservation</li> <li>iii. Levelling the plots by local leveler</li> </ul>  |

|   |  |  |
|---|--|--|
|   |  | <ul style="list-style-type: none"> <li>iv. Opening up set furrow</li> <li>v. Conservation furrow : Gurr</li> </ul>   |
| 5 | <b>Soil Amendment / Mulching</b>                                     | <ul style="list-style-type: none"> <li>i. Application of tank silt</li> <li>ii. Application of ground nut shells</li> <li>iii. Sand mulching</li> <li>iv. Gravel sand mulching</li> <li>v. Retention of pebbles on the soil surface</li> <li>vi. Retention of sunflower stalks</li> <li>vii. Mulching of Sal leaf in turmeric</li> <li>viii. Crop residue application in the field</li> </ul>  |
| 6 | <b>Erosion Control &amp; Runoff Diversion Structures</b>             | <ul style="list-style-type: none"> <li>i. Sand bags as gully check</li> <li>ii. Loose boulder checks</li> <li>iii. Stone waste weir</li> <li>iv. Waste weir (stone / sorghum stubbles) at the outlet of the field</li> <li>v. Brushwood structure across the bund</li> <li>vi. Grassed waterways</li> <li>vii. Spur structure</li> <li>viii. Nala plugging</li> </ul>  |
| 7 | <b>Water Harvesting, Seepage Control &amp; Ground Water Recharge</b> | <ul style="list-style-type: none"> <li>i. Seepage control by lining farm ponds with white soil</li> <li>ii. Harvesting of seepage water</li> <li>iii. Wells as runoff storage structures</li> <li>iv. Rain water management using indigenous rain gauge (<i>Role</i>)</li> <li>v. Farm pond</li> <li>vi. Percolation pond / tank</li> <li>vii. Ground water recharging through ditches and percolation pits</li> <li>viii. Well recharging through runoff collection pits</li> <li>ix. Dug wells</li> <li>x. Haveli / Bharel system</li> <li>xi. Bandh system of cultivation</li> <li>xii. Earthen check dams</li> <li>xiii. Field water harvesting</li> <li>xiv. Nadi farming system</li> <li>xv. Collection of sub-surface runoff water and recycling in Diara land</li> <li>xvi. Rain water harvesting from roof top and road surfaces</li> <li>xvii. Rain water harvesting in <i>Kund / Tanka</i></li> </ul> |

### Refinement of ITKs for Promotion of the Technologies

Some potential ITKs/ILKs identified for further study, research and development of new projects is presented in Table 3. A scientific study may change this Indigenous Technical Knowledge to Modern Technical Knowledge (MTK).



**Table 3. Identification of researchable Issues of some selected ITKs**

| Name of ITK   | Purpose   | Researchable Issues  |
|---|---|--|
| Furrow opening in standing crops                          | Rainwater conservation  | <ul style="list-style-type: none"> <li>◆ Modification of implement with different serrated blades and introducing additional tines</li> <li>◆ Effectiveness in conserving soil moisture</li> </ul>   |
| Nadi farming system                                       | To collect runoff during <i>kharif</i> for life saving irrigation during drought spell or pre-sowing irrigation ( <i>Palewa</i> ) for <i>rabi</i> crops | <ul style="list-style-type: none"> <li>◆ Documentation and analysis of socio-economic aspect of present <i>nadi</i> system for its sustainability</li> <li>◆ Evaluation of present <i>nadi</i> farming system</li> </ul>                           |
| Mixed pulses as vegetative barrier                        | Resource conservation   | <ul style="list-style-type: none"> <li>◆ Proportion of pulses as vegetative barrier</li> <li>◆ Cost effectiveness of the system</li> </ul>   |
| Stabilization of gullies using sand bags                  | Gully control and runoff management   | <ul style="list-style-type: none"> <li>◆ Soil conservation efficiency</li> <li>◆ Strengthening of sand bags structure with different vegetative barriers</li> </ul>  |
| Application of white soil as lining material in farm pond | To work as a sealant material for lining dugout farm pond   | <ul style="list-style-type: none"> <li>◆ Standardization of application technique and economic feasibility for wider application</li> <li>◆ Study on the seepage losses at different hydraulic heads</li> </ul>                                    |
| Wider row spacing in pearl millet                         | Rainwater conservation and weed control   | <ul style="list-style-type: none"> <li>◆ Plant geometry and population research in different rainfall situations</li> </ul>  |
| Rainwater harvesting in <i>kund/tanka</i>                 | The harvested water in <i>kund</i> / <i>tanka</i> is used for drinking and establishment of tree  | <ul style="list-style-type: none"> <li>◆ Research should be done on the use of stored water for arid horticulture</li> <li>◆ Design of <i>tankas</i> for different geo-hydrologic conditions</li> </ul>  |
| Crop stubbles and residue management                      | Improve the organic matter and water holding capacity of soil   | <ul style="list-style-type: none"> <li>◆ Quantification of soil and water conserved and yield advantage</li> <li>◆ Better or improved implements for crop residue incorporation</li> <li>◆ Alternate ways of composting and application</li> </ul> |
| Brush wood waste weir                                     | Safe disposal of excess runoff  | <ul style="list-style-type: none"> <li>◆ Design and stabilization of structure</li> </ul>  |
| Mulching in turmeric                                      | To conserve rainwater   | <ul style="list-style-type: none"> <li>◆ Quantification of soil loss, improvement of soil quality and water availability</li> <li>◆ Use of alternative organic material to <i>Sal</i> leaves as mulch</li> </ul>                                   |
| Indigenous stone / brush wood structure across the slope  | To check soil loss  | <ul style="list-style-type: none"> <li>◆ Shape and size of brush wood structure depending on the runoff and site conditions</li> </ul>   |

|   |  |   |
|---|--|---|
| Agave sp. as vegetative barrier                         | To reduce runoff velocity and to increase infiltration opportunity time                          | <ul style="list-style-type: none"> <li>◆ Different species of Agave can be evaluated</li> <li>◆ Cost-benefits analysis.</li> </ul>  |
| Broad bed and furrow practice                           | To harvest rain water and dispose of runoff  | <ul style="list-style-type: none"> <li>◆ Width of broad bed needs to be evaluated for different crops and rainfall situations</li> <li>◆ Identification of suitable low cost tractor/bullock drawn implement for layout of BBF</li> </ul>   |
| Water harvesting and recycling                          | Rain water harvesting and recycling to crop field as supplemental irrigation                     | <ul style="list-style-type: none"> <li>◆ Recharging of water table</li> <li>◆ Cost effectiveness</li> <li>◆ Improvement in crop yield</li> </ul>  |
| Standardization of recharging technique                 | Augmentation of ground water   | <ul style="list-style-type: none"> <li>◆ Design of filter and improvement in filtering efficiency with better filtering material.</li> <li>◆ Effect of geology/soil formation on recharge</li> </ul>  |
| Set-row cultivation                                     | For harvesting rain water and maintaining soil structure   | <ul style="list-style-type: none"> <li>◆ Quantification of rainwater conservation and water use efficiency (WUE) of the crops</li> <li>◆ Improvement in soil health and crop yield over years</li> </ul>  |
| Summer / pre-monsoon tillage                            | Conservation tillage-to harvest early showers, facilitate timely seeding and weed control        | <ul style="list-style-type: none"> <li>◆ Identification of appropriate tillage implements for soil and water conservation</li> <li>◆ Evaluation of root: shoot ratio and quantification of WUE of crops</li> </ul>  |
| Ridge & furrow planting for modulation of overland flow | Conservation of rain water, modulating excess water, control soil loss and boosting productivity | <ul style="list-style-type: none"> <li>◆ Fabrication and development of ridge former accommodating required row spacings and ridge cross- section</li> </ul>  |
| Formation of <i>Gurr</i>                                | Reduction of runoff and soil moisture conservation   | <ul style="list-style-type: none"> <li>◆ Effect of bullock and tractor made <i>Gurr</i> on runoff reduction, soil water conservation and crop productivity</li> </ul>   |
| Green manuring practice                                 | To conserve soil water and improve soil health   | <ul style="list-style-type: none"> <li>◆ Growing of green manure crop and its management in improving soil health and crop productivity</li> <li>◆ Economic evaluation of the system by addressing sustainability issues</li> </ul>   |
| Application of tank silt                                | To increase the fertility and water holding capacity of soil                                     | <ul style="list-style-type: none"> <li>◆ Method and quantity of tank silt application in different soils</li> <li>◆ Improvement in soil water and fertility with tank silt application and its effect on crop productivity</li> <li>◆ Cost effectiveness of silt application especially with Government programme of tank desiltation.</li> </ul> |

## Conclusions

Many ITKs on in-situ soil and moisture conservation are not widely adopted throughout India because of constraints in adoption and unawareness of the effectiveness of such practices. The present documentation process has definite bearing on the future course of action in framing new projects. This short-term documentation project may lead to the following future activities:

1. Similar exercise can be undertaken to document the ITKs/ILKs from all the Agro-ecological regions of the country.
2. The potential ITKs may be tested for their suitability and adoption in other Agro-ecological regions as a dissemination strategy.
3. The documented ITKs may be published/translated in all regional languages for the benefit of the farming communities.
4. Validation of the ITKs is a logical step to qualify and quantify the effectiveness of these practices. Suitable modifications of the traditional practices through on-farm research would help in developing appropriate and acceptable technologies for different local environments.
5. The effect of conservation measures on resource losses can be studied in detail through experimentation and use of stimulation model.
6. As a policy matter the local ITKs should be in built in the resource conservation programme.

---

## Potential Diversified Dryland Horticulture for livelihood enhancement in watersheds

*Anusha N M*

*Scientist (Fruit Science), ICAR-Indian Institute of Soil and Water Conservation,  
Research Centre, Ballari*

---

### Introduction

A watershed is technically considered a geo-hydrological unit or an area that drains to a common point. A region enclosed by a ridge line and draining into a single outlet is referred to as a watershed, catchment, or drainage basin. More precisely, it provides water to a certain drainage system or body of water—be it a stream, river, wetland, lake, or ocean—by surface or subsurface flow. The interactions between land and water, specifically the underlying geology, rainfall patterns, slope, soils, vegetation cover, and land use, result in the watershed. The survival of creation depends on the essential natural resources that nature has given to humans, such as soil, water, and vegetation. Better planning and the sustainable growth of every nation depend on the appropriate inventory and periodic management of its natural resources. The sustainable management of these resources will determine their availability for use by future generations (Sitaram, 2012). Rainfed agriculture, which includes both dry farming and Dryland agriculture, is the main agricultural practice in India. The Indian subcontinent receives an estimated 1200 mm of rainfall annually on average. Based on this, 400 m.ha.m (4000 km<sup>3</sup>) of precipitation, including snowfall, is estimated annually. The distribution, however, differs throughout the nation, ranging from less than 100 mm in the most arid regions of western Rajasthan to more than 3600 mm in the northeastern provinces, and from 1000 mm on the east coast to between 2500- 3000 mm on the west coast (Singh et al., 2013). Dry lands are regions with limited access to soil and water resources; they make up around 41.3% of the world's land area and 44% of all farmed systems; also, they are home to roughly 2 billion people. Increasing widely dispersed growth and output on dry soils is crucial for achieving sustainability. In dryland horticulture; it is more difficult to get a significant yield profit than in irrigated horticulture. Therefore, it is imperative to prepare for a steady increase in crop productivity by utilising resources in semi-arid and dry zones more effectively (Jena et al., 2023). If the farming community is encouraged to use suitable technology created by the National Agricultural Research System (NARS), these issues can be reversed, stopped, or at least lessened. This is only feasible if the farming system that is popular in these regions is modelled after an economy-driven enterprise. This implies that a farmer's revenue from the holding ought to be higher and distributed over time. Because of

numerous human endeavours; there is no possibility to increase the farmed area. Agriculture must increase vertically through intensification and diversification in order to meet future demands. For various regions of the county, a sustainable cropping pattern incorporating legumes, trees, high-value crops like fruits and vegetables, and animal components is being created. The productivity of small and marginal farmers who lack resources is always increased by the use of dryland horticulture techniques. Vegetable crops easily integrate into the system due to their short duration and rapid growth characteristics. Fruit trees can easily adapt to marginal agro-ecological conditions such as undulating uplands, gullied and ravined lands, mining and industrial waste lands, and poor sandy plains because of their perennial nature and deep root system, which allows them to utilise the moisture typically stored in deeper soil profiles. As a result, they can improve the degraded ecology (Singh et al., 2013). Techniques for farming on dry land include conserving water, increasing water absorption, minimising soil moisture loss, contour bunding, bunding and terracing, mulching, intercropping, precision agriculture, using drip irrigation, and applying pesticides and growth regulators. Selecting the right variety is crucial. Dry land conditions are often unsuitable for varieties that have demonstrated their superiority in irrigated areas. A lot of dry land farming projects have failed, mostly because the needs for variety selection were not understood. (Mallikarjuna rao et al., 2015).

### **Scope of diversified Dryland Horticulture**

- The arid and semi-arid regions of India are currently the only non-traditional areas accessible. where a few chosen horticultural crops can be grown with little to no additional watering.
- Horticulture is a viable option for farmers looking to increase revenue. Since it has been discovered that a number of highly valuable fruit crops, including ber, aonla, and custard apples, as well as vegetables, mostly legumes, medicinal, and fragrant plants, are extremely well-suited for growth in dryland environments.
- Rainfall in arid regions is not only low but also sporadic, occurring only from July to September. As a result, the best fruit-growing strategies are those that select fruit species with high food and industrial value, such as ber, lasoda (*Cordia mixa*), kair (*Capparis decidua*), and pilu (*Salvadora oleoides*), which finish their reproductive phase well before the stress period.

- The majority of India's dryland (arid and semi-arid) regions have saline to alkaline soils, which make it impossible to grow cereal crops there. Nonetheless, a number of fruit crops, including pomegranates, date palms, aonla, and ber, can be grown effectively in such edaphic environments.

### **Challenges in dryland horticulture**

- ✓ Soil fertility: Low in nutrients and requires additional inputs
- ✓ High evaporation rates and high temperature
- ✓ Low productivity
- ✓ Sparse vegetation
- ✓ Wind erosion and dust storms
- ✓ Dry and arid conditions
- ✓ Water scarcity/Limited rainfall

### **Characteristic features of dryland horticulture crops**

- ✓ Dryland crop should be deep rooted & perennial crops.
- ✓ Dry land crop should be of low water requirement crop.
- ✓ The crop should have thick & small leaves & should be shiny.
- ✓ Crops should be hardy & tolerant to rigorous monsoon
- ✓ Crops should shed their leaves during summer & put forth flowering & fruiting during rainy season.
- ✓ Low spreading canopy to minimize exposure to sun and wind (e-shiksha portal)

### **Techniques used in dryland horticulture**

#### **1. Micro- irrigation: Drip irrigation, sprinkler irrigation**

The drip and micro sprinkler are two types of micro irrigation techniques, which can be used to improve irrigation efficiency for vegetables by reducing field losses. (Shivanand et al., 2012)

#### **2. Mulching**

Evaporation losses range between 60 and 75 percent of the precipitation. The application of mulches helps minimize these evaporation losses. Any material spread on the soil's surface to reduce evaporation and enhance soil water content is called mulch. Other advantages of

applying mulches include improving soil structure, lowering soil salinity, regulating temperature, controlling weeds, and conserving soil.

### Types of mulches

1. **Soil mulch or dust mulch:** When soil is loosening up on the surface, it functions as a mulch to lessen evaporation. Dust or soil mulch are terms used to describe this loose surface dirt. In a crop that is growing, intercultivation produces soil mulch.
2. **Stubble mulch:** Crop leftovers, such as cotton stalks or wheat straw, are spread out as stubble mulch over the soil's surface. Reducing evaporative losses and shielding the soil from erosion are two benefits of stubble mulch farming.
3. **Straw mulch:** If straw is used as mulch, it is called as straw mulch.
4. **Plastic mulch:** Plastic materials like polyethylene, polyvinyl chloride are also used as mulching materials.
5. **Vertical mulching:** Vertical mulches are created to enhance precipitation uptake and storage in these soils. The method involves periodically excavating slender trenches down the slope and filling them with crop waste or straw. Every year, the chopped plant material is deposited in contour trenches either in the spaces between rows or in trenches around the plants in a single, concentric circle.

### 3. Crop and variety Selection: Drought resistant

- ▶▶ **Fruit crops for dry lands:** The crops must have xeric characters, eg. deep root system (as in mango, ber, walnut), summer dormancy (as in ber), high bound water in the tissues (as in cactus, pear, fig), reduced leaf area (as in Indian gooseberry), leaf surface having shrunken stomata, thick cuticle wax coating and pubescence (as in fig, ber, phalsa, tamarind), and ability to adapt shallow soils, rocky, gravelly, and undulating wastelands (eg. pomegranate, anola, cashew, *Buchanarialanzan*). (Singh *et al.*, 2013)
- ▶▶ **Vegetable crops for drylands:** Among the vegetable crops, bottle gourds (*Lagenaria siceraria*), ridge gourd (*Luffa acutangula*), sponge gourd (*Luffa cylindrica*), water melon (*Citrulluslanatus*), round melon (*Citruluslantis* var. *fistulosus*), long melon (*Cucumis melo* var. *utilisimus*), bitter gourd (*Momordica charantia*), snap melon (*Cucumis melo* var. *momordica*), kachari (*Cucumis callosus*), Arya (*Cucumis sp.*), drumstick (*Moringa deifera*), cluster bean (*Cyamopsis tetragonoloba*), cowpea (*Vigna*

*unguiculata*), okra (*Abelmoscous esculentus*), amaranth (*Amaranthus sp.*), brinjal, chilli and tomato are common. (Singh et al., 2013)

#### **4. Intercropping, precision agriculture**

Growing two or more crops concurrently on the same field for a duration long enough to encompass the vegetative stage is known as intercropping. Farmers can reduce soil erosion, preserve soil fertility, and maximise water use efficiency by planting multiple crops concurrently in the same field—all major disadvantages of monocropping (Hoshikawa, 1991).

#### **5. Bunding, terracing, contour bunding**

Water harvesting utilising an in-situ or ex-situ method can enhance the plant's water supply. Micro catchment slopes above 5 percent have been shown to have no discernible effect on runoff at Jodhpur. The best ber yields were recorded at 0.5 percent and 5 percent slopes with 8.5 m and 7 m of flow length and 72 m<sup>2</sup> and 54 m<sup>2</sup> catchment area per tree, respectively (Sharma et al. 1982, 1986; Evenari et al. 1971).

#### **6. Wind breaks and Shelter belts**

##### **Advantages of windbreaks**

- ▶▶ Windbreaks reduce the wind velocity and minimize the damage to fruit trees.
- ▶▶ They minimize the adverse effect of high and low temperature on plants; thereby, help developing a micro-climate in surroundings that encourages plant growth.
- ▶▶ Activity of pollinating insect will be enhanced.
- ▶▶ They provide large quantity of biomass (leaves) for manuring and mulching.
- ▶▶ They can provide fodder, firewood and small timber in limited quantities

##### **Characteristics of trees for windbreak**

- ▶▶ The trees should be tall growing and sturdy enough to withstand strong winds.
- ▶▶ They should be profusely branching.
- ▶▶ They should have high regenerating capacity, if they are pruned during non-windy season to have sufficient interlocking branches during windy season.
- ▶▶ They should have minimum or no adverse effect from the wind on their growth and physiological functions



- ▶▶ Some of the most common trees, which are used as wind breaks are Shisham (*Dalbergia sissoo*), Mulberry (*Morus alba*), Jamun (*Syzygiumcumini*), Bordi (*Zizyphus rotundifolia*), Neem (*Azadirachta indica*), Lasoda (*Cordia myxa*), Babool (*Acacia tortilis*), Khejri (*Prosopis cineraria*) etc. (Saroj *et al.*, 2004).

### Shelter belts

- ▶▶ Shelter belts are wide and long belts of several rows of shrubs planted across the prevailing wind direction to deflect wind currents to reduce wind velocity and provide general protection against sand movement of vast fields.
- ▶▶ Tree species such as *Acacia tortilis*, *Prosopis juliflora* (Israel variety), *Cassia siamea*, *Azadirachta indica*, *Albizzia lebbek*, *Acacia nilotica spp. Cupressiformis* etc. and shrubs like phalsa, karonda, khimp (*Leptodeniapyrotechnica*) or phog (*Calligonumpolygonoides*) are suitable for the purpose of establishing shelter belt.

### Need for diversification

When the world's population reaches 9 billion in 2050, India's population is predicted to be between 1.64 and 1.74 billion. By 2050, 199 million tonnes (Mt) of vegetables and 146 Mt of fruits are expected to be needed to feed this population. Likewise, by 2050, demand for seed spices—another significant horticultural commodity—is expected to triple from its current level. However, as a result of population growth, urbanisation, and industrialization, there is less land accessible for agriculture. In dry and semi-arid locations, there is a substantial amount of marginal and waste land that can be used to cultivate horticulture crops in order to meet the increasing demand (Saroj *et al.*, 2019). Without a doubt, the country's fruit crop diversity has demonstrated its potential for profitable diversification. With the world's population expected to increase steadily and the amount of land available per person to decrease to just 0.68 hectares by 2020, fruit-based varied cropping systems are now seen to be the best way to provide food, nutrition, and financial stability for people. The fruit sector faces a number of obstacles in addition to land resource depletion, including national issues like environmental degradation, climate change, heat stress, water scarcity, groundwater contamination, and the introduction of harmful compounds into the food chain. In such circumstances, integrating annual crops with fruit trees appears to be a workable solution as it would provide several outputs, guarantee production, and generate cash in an environmentally friendly way. Both socioeconomic inputs (labour, credit, electricity, market

infrastructure) and natural resources (land, solar radiation, water, and soil) could be used effectively to increase the system's resilience over time. Native Americans have long recognised the benefits of integrating annual/seasonal crops with perennial fruit trees and plantation crops. This is because planting multiple species together promotes ecological stability and sustainable output. Diversification has led to a number of recent developments and new research and development activities aimed at increasing productivity and production.

### **Status of dryland horticulture in India**

The country's horticultural development has a lot of opportunities due to the abundant land resources in arid regions. Over the past 25 years, a significant amount of land has been planted with fruits in various sections of the country, including aonla, ber, pomegranate, fig, kinnow, date palm, phalsa, and tamarind. Large orchards of underappreciated fruits such as jamun, mahua, chironji, khirni, wood apple, fig, karounda, lasoda, Manila tamarind, etc., could be developed. Rainfed circumstances are used to cultivate some traditional crops, such as guar, moth, mateera, kachari, tinda, and snap melon. The vegetable seed industry in India has grown significantly over the last ten years, but the main concentration is still on a small number of vegetables, such as bell pepper, cauliflower, onion, tomato, brinjal, okra, and cucumber (Saroj *et al.*, 2019).

### **Benefits of fruit-based cropping**

- Profitability-boosting substitutes for the conventional monocropping system that work well
- Self-sustaining system that makes effective use of soil resources and allows for the harvesting of solar energy at various altitudes.
- An excellent way to reduce crop failure from bad weather.
- Allows farmers to survive and earn a respectable profit even in poor agro-ecological conditions.
- Increased cropping intensity.
- Mineral nutrition source to increase nutritional security in the household.
- Provides valuable bi-products like fodder and fuel wood through annual pruning apart from fruits. (Krishna *et al.*, 2018)

## Impact of diversification dryland horticulture in drylands

### a. Improve farmer's income

Compared to just 0.05% for rice and -0.06% for wheat, the income elasticity for fruits and vegetables is stated to be 0.42% and 0.35%, respectively. A khejri-based cropping strategy has been estimated to provide growers with a net profit of Rs. 75,000–2,25,000 ha/year. Similarly, growers can benefit from a net profit of 0.7 to 1.0 lakh rupees from a multiple cropping system based on ber or aonla.

### b. Reduces the risk of crop failure

When diversification is done well, it frequently leads to a more varied mix of activities, both vertically in economic sectors such as developing processing industries and new input markets and at the regional level of farm operations. As a result, there will be less reliance on a limited range of outputs, which will lessen the community's susceptibility to shocks from unpredictable weather patterns and volatile commodity prices.

### c. Conservation of natural resources

Horticultural crop diversification can lead to better natural resource management. This has the potential to lessen land degradation, increase input-use efficiency, and protect biodiversity.

### d. Employment opportunities

Horticulture crops require more man power for various activities like propagation, pruning, training, harvesting, grading etc.

## Horticulture-based cropping systems

### Crops and Varieties for diversified cropping system

The overstorey main crop, component crop, and understorey intercrops are the three primary parts of the varied cropping system.

**Main crop:** These are the perennial fruit species with longer juvenile and productive phases and a bigger canopy. After 20 to 25 years, the crops usually take up all of the area, but the main crop only uses up 25 to 30 percent of the land for up to 10 years. They are planted farther apart. Several drought hardy fruit crops like *Capparis decidua*, *Salvadora oleoides*, *Cordia myxa*, *Cordia gharaf*, *Zizyphus nummularia*, *Z. rotundifolia*, *Z. mauritiana* are suitable for the areas receiving rainfall <300 mm. Besides providing fruits these plants produce moisture laden nutritious leaves for animal. Several other fruits such as *aonla*,

pomegranate, *bael* (*Aegle marmelos*), date palm, tamarind (*Tamarindus indica*) can be grown in the area having irrigation facilities.

In arid regions, fruit trees provide multiple purposes. They can stop soil erosion and serve as a stabiliser for the soil. Moreover, they offer superior soil protection than annual plants. Their deep root system enriches the soil, and the shade trees offer helps the environment survive. When herbaceous fodder, such as ber, fig, mulberry, etc., is scarce, they serve as a vital source of food for cattle and wildlife.

**Component crops:** These fruit species are cultivated alongside the primary crop in order to vary the cropping system and meet the needs of the grower. They might also be produced as filler crops, planted just while the main crop is still in its juvenile stage, and then removed later. The other important fruit crops, which can be grown along with *ber* in arid regions as component tree are *aonla* (*Emblica officinalis*) (in frost-free area), *phalsa* (*Grewia subinequalis*), *karonda* (*Carissa carandas*), *goonda/lasora* (*Cordia myxa*), mulberry (*Morus* sp.), fig (*Ficus* sp.), *bael* (*Aegle marmelos*) etc., while custard apple (*Annona squamosa*), wood apple (*Feronia limonia*), *bael* (*Aegle marmelos*), *aonla* (*Emblica officinalis*), guava (*Psidium guajava*), mahua (*Madhuca indica*) and chironji (*Buchania lanzan*) are suitable for growing as component crop with *ber* in semi-arid regions.

**Ground storey intercrops:** An additional feature of the cropping system based on fruit trees is the growth of annual crops in the interspaces. Grown in the empty areas between tree rows, the intercrop takes up the lowest layers of the system. Intercrops are typically annual crops that are chosen for a particular place based on socioeconomic and environmental factors. These could be vegetables, pulses and legumes, oilseed, fodder crops, medicinal plants and seed spices. Among the vegetable crops, cucurbits like *mateera* (*Citrullus lanatus*), ridge gourd (*Luffa acutangula*), sponge gourd (*Luffa cylindrica*), bottle gourd (*Lagenaria siceraria*), long melon (*Cucumis melo* var. *utilissimus*), snap melon (*Cucumis melo* var. *momordica*), round melon (*Parecitrullus fistulosus*), kachri (*Cucumis* spp.), and legumes such as clusterbean (*Cyamopsis tetragonoloba*) and cowpea (*Vigna unguiculata*) can be taken successfully. Similarly, *kharif* pulses such as moth bean (*Phaseolus aconitifolius*), mung bean (*Phaseolus radiatus*) and urd bean (*Phaseolus aureus*) and *rabi* legume chick pea (*Cicer arietinum*) can be raised as they are able to withstand extreme aridity. Rapeseed (*Brassica*

*campestris toria*) and mustard (*Brassica campestris*) are important oilseed crops, which can also be included in *ber* based farming system.

| Main crop   | Component crops  | Ground storey intercrops   |
|---|--|--|
| <i>Capparis decidua</i> , <i>Salvadora oleoides</i> , <i>Cordia myxa</i> , <i>Cordia gharaf</i> , <i>Zizyphus nummularia</i> , <i>Z. rotundifolia</i> , <i>Z. mauritiana</i> , <i>aonla</i> , pomegranate, <i>bael</i> ( <i>Aegle marmelos</i> ), date palm, tamarind ( <i>Tamarindus indica</i> ), fig, mulberry | <i>Aonla</i> ( <i>Emblica officinalis</i> ) (in frost-free area), phalsa ( <i>Grewia subinequalis</i> ), karonda ( <i>Carissa carandas</i> ), goonda/lasora ( <i>Cordia myxa</i> ), mulberry ( <i>Morus</i> sp.), fig ( <i>Ficus</i> sp.), <i>bael</i> ( <i>Aegle marmelos</i> ) etc., while custard apple ( <i>Annona squamosa</i> ), wood apple ( <i>Feronia limonia</i> ), <i>bael</i> ( <i>Aegle marmelos</i> ), <i>aonla</i> ( <i>Emblica officinalis</i> ), guava ( <i>Psidium guajava</i> ), mahua ( <i>Madhuca indica</i> ) and chironji ( <i>Buchanania lanzan</i> ). | Among the vegetable crops, cucurbits like <i>mateera</i> ( <i>Citrullus lanatus</i> ), ridge gourd ( <i>Luffa acutangula</i> ), sponge gourd ( <i>Luffa cylindrica</i> ), bottle gourd ( <i>Lagenaria siceraria</i> ), long melon ( <i>Cucumis melo</i> var. <i>utilissimus</i> ), snap melon ( <i>Cucumis melo</i> var. <i>momordica</i> ), round melon ( <i>Parecitrullus fistulosus</i> ), kachri ( <i>Cucumis</i> spp.), and legumes such as clusterbean ( <i>Cyamopsis tetragonoloba</i> ) and cowpea ( <i>Vigna unguiculata</i> ), <i>kharif</i> pulses such as moth bean ( <i>Phaseolus aconitifolius</i> ), mung bean ( <i>Phaseolus radiatus</i> ) and urd bean ( <i>Phaseolus aureus</i> ) and <i>rabi</i> legume chick pea ( <i>Cicer arietinum</i> ), Rapeseed ( <i>Brassica campestris toria</i> ) and mustard ( <i>Brassica campestris</i> ) |

### Multistory cropping system

It basically involves using variable heights, root depths, and crop canopy to grow plants of varied heights simultaneously in the same field. Highest total income and net profit was realized with *bael*+ groundnut intercropping followed by *ber*+groundnut and kinnow + groundnut (Yadava et al., 2006)

Examples: *Aonla-ber*-brinjal-moth bean, *Aonla*-drumstick- senna-moth bean-cumin, *Aonla-Khejri-Suaeda*-moth bean-mustard, *aonla-ber*-brinjal-moth bean-fenugreek, *aonla-ber*-clusterbean-fennel

### Aonla based fruit cropping system

Aonla-based hortipastoral system involving *Dichanthium annulatum* with four nitrogen doses viz., 0, 20, 40 and 60 kg ha<sup>-1</sup> to the grass as understory forage species was studied for ten consecutive years (1996-2005). Highest dose of N (60 kg ha<sup>-1</sup>) gave significantly higher dry pasture yield (4.04 t ha<sup>-1</sup>) with aonla tree compared with the pure pasture condition (3.73 t ha<sup>-1</sup>). The pasture production was marginally higher in association with trees (3.38 t DM ha<sup>-1</sup>) as compared to pure pasture (3.07 t DM ha<sup>-1</sup>) (Kumar et al., 2009).

### Ber based cropping system

In order to measure the system's potential, the ber (*Ziziphus mauritiana L.*) based cropping system was started in the hot, dry environment of western Rajasthan under irrigation. *In situ* budded ber cv Gola with three spacings (6x6m, 8x8m and 16x4m) as overstorey component and groundnut (*Arachis hypogea*) - wheat (*Triticum aestivum*), cluster bean (*Cyamopsis tetragonoloba*) - mustard (*Brassica campestris*) and Indian aloe (*Aloe barbadensis*) as groundstorey components were integrated into the system. The findings showed that there was no resource competition between the overstorey and groundfloor components throughout the early stages of its establishment. The investigation revealed that cluster bean - mustard and Indian aloe can be integrated as a compatible groundstorey component with ber as compared to groundnut, wheat, which is a dominant rotation in the irrigated hot arid ecosystem (Saroj et al., 2003).

### Seed Spice based cropping system

Under intercropping situations, the seed spices being arid land spices grow well as component crop in arid fruit orchards viz. Aonla, Ber and Pomegranate. Similarly in Fennel, Ajowan, Dill crops, the vegetable crops viz guar (cluster bean) for green pods, summer squash, chillies, onion, radish and carrot can be intercropped (Malhotra, 2004)

### Cost Benefit of fruit based cropping system

In an attempt to study benefit: cost under fruit based multiple cropping system, maximum benefit:cost ratio of 3.48:1 was observed when crops were grown under combination of Aonla + Ber + Karonda + Moth bean + Mustard. Among the perennial components, higher benefit: cost ratio (2.22:1) was found under ber (Arya et al., 2011).

## References

- Sitaram, S. S. 2012. Role of Agroforestry in Watershed Management.
- Jena, L., Atal, H. L., Pradhan, S., Sahu, S., Ichancha, M., Srilakshmi, D., ... & Sahoo, J. P. (2023). Unlocking potential of Dryland horticulture in climate-resilient farming. In *Enhancing Resilience of Dryland Agriculture Under Changing Climate: Interdisciplinary and Convergence Approaches* (pp. 343-382). Singapore: Springer Nature Singapore.
- Mallikarjunarao, K., Pradhan, R., & Das, R. K. (2015). Dry land techniques for vegetable production in India-A review. *Agricultural Reviews*, 36(3), 227-234.
- Singh, S. R., Singh, A. K., Singh, R. P., & Lal, J. P. (2013). Adoption of agro-horti system for the sustainable development of dryland agriculture-an overview. *J Andaman Sci Assoc*, 18(1), 39-46.
- Sharma, K.D., O.P. Pareek & H.P. Singh (1986): Micro- catchments water harvesting for raising jujube orchards in arid climate. *Trans ASAE* 29:112- 118.
- Sharma, K.D., O.P. Pareek & H.P. Singh (1982): Effect of runoff concentration on growth and yield of jujube. *Agriculture and Water Requirement* 5: 73-84.
- Evenari, M., L. Shanon & T. Tadmor (1971): *The Negev; The challenge of a desert*, Cambridge, Massachusetts, USA: Harvard University Press.
- Malhotra, S.K. 2004. Potential of seed spices production for crop diversification. National Seminar on Opportunities and Potential of Spices for Crop Diversification. Jan, 19-21, at JNKVV Jabalpur,
- Shivanand, H. K., Santosh, D. T., Madhusudhan, M. S., & Mane, A. (2012). Effect of Micro Irrigation on Growth and Yield of Tomato under Clay Loam Soil. *Indian Horticulture Journal*, 2(3and4), 60-64.
- Hoshikawa, K., 1991. Significance of legumes crops in intercropping, the productivity and stability of cropping system. pp. 173-176. In: C. Johanson, K.K. Lee and K.L. Saharawat, (eds.). *Phosphorus Nutrition of Grain Legume in the Semi-Arid Tropics*. ICRISAT.

- Saroj, P.L., Vashishtha, B.B. and Dhandar, D.G. 2004. *Advances in Arid Horticulture*, Vol. I, International Book Distributing Company, Lucknow, India. P. 628.
- Awasthi, O. P. (2018). Fruit based diversified cropping system: an alternative approach for nutritional and economic security. *Progressive Horticulture*, 50(1and2), 41-46.
- Krishna H., Saroj, P.L., Jatav, M.K. and Awasthi, O.P. (2018). Fruit based cropping models to increase farmer's income- An experience of arid region. CIAH/ Tech./Pub. No. 70,pp 61. ICAR- Central Institute for Arid Horticulture, Bikaner, Rajasthan, India.
- Kumar, S., Kumar, S., & Choubey, B. K. (2009). Aonla-based hortipastoral system for soil nutrient buildup and profitability. *Annals of Arid Zone*, 48(2), 153.
- Saroj, P. L., Dhandar, D. G., Sharma, B. D., Bhargava, R., & Purohit, C. K. (2003). Ber (*Ziziphus Mauritiana* L.) based agri-horti system: a Sustainable land use for arid ecosystem. *Indian Journal of Agroforestry*, 5(1&2).
- Arya, R., Awasthi, O. P., Singh, J., & Singh, B. (2011). Cost benefit analysis uner fruit based multiple cropping system. *Progressive Horticulture*, 43(1), 72-75.
- Saroj, P. L., & Sharma, B. D. (2019). Horticulture based diversification: an option for enhancing farmers' income in drylands. OP yadav and NR Panwar (eds.). 2019.
- Yadava, N.D., R.K. Beniwal and M.L. Soni. 2006. Crop diversification under fruit based cropping systems in arid zone of western Rajasthan. *Indian Journal of Arid Horticulture* 1(1): 20-22.



## Green cover enhancement techniques in the watershed area

*M.N. Ramesha<sup>1</sup>, H.C. Hombegowda<sup>2</sup>, S.L. Patil<sup>3</sup>, M.R. Jagadish<sup>4</sup>, and S. Raghavendra<sup>5</sup>.*

*<sup>1</sup>Senior Scientist, ICAR-IISWC, RC, Ballari, <sup>2</sup>Senior Scientist, ICAR- IISWC, RC, Udthagamandalam, <sup>3</sup>Principal Scientist, ICAR-IIPR, RS, Dharwad, <sup>4</sup>Assistant Professor, College of Forestry, Sirsi, <sup>5</sup>Associate Professor, College of Agriculture, GKVK UAS, Bengaluru.*

### Introduction

Green cover is the area covered by trees on earth. The United Nations Economic Commission for Europe define the Mountain Green Cover Index, as a measure detect the changes of the green vegetation in mountain areas - i.e. forest, shrubs, trees, pasture land, crop land, etc. The index will provide information on the changes in the vegetation cover and, as such, will provide an indication of the status of the conservation of mountain environments. Greening (browning) is defined as a statistically significant increase (decrease) in annual-average green leaf area at a location over a period of several years (Chen et al., 2019). It could be a result of changes in average leaf size, leaf number per plant, plant density, species composition, and duration of green-leaf presence due to changes in growing season and multiple cropping, etc.

### India's green cover

According to the Forest Survey of India's biennial India State of Forest Report 2021, India has 71.38 million ha surface-land-area under forest and 9.57 million ha area under tree cover. Further, the reports highlight that increases in forest cover within the recorded forest area (RFA) or greenwash (GW) area is 3100 ha whereas an increase in forest cover outside RFA/GW area is 1,50,900 ha compared to the previous 2019 assessment (FSI, 2021). This clearly envisages that there is a large-scale effort from the public toward the greening of the nation by growing trees outside the forests (TOFs). This was corroborated by a scientific publication in 2019 and claimed that China and India leaders in greening of the world through land-use management (Chen et al., 2019). However, the per capita forest cover of India is ~0.06 ha.

### World's green cover

The global forest cover is about 4.06 billion hectares (ha), which is 31 percent of the total land area. The global per capita forest cover is 0.52 ha– although forests are not distributed equally among the world's people or geography. The tropical region has the largest proportion of the world's forests (45 percent), followed by the boreal, temperate and subtropical

domains. More than half (54 percent) of the world's forests is in only five countries –the Russian Federation (20%), Brazil (12%), Canada (9%), the United States of America (8%), and China (5%). They absorb roughly 15.6 billion tonnes of carbon dioxide (CO<sub>2</sub>) every year. An estimated 420 million ha of forest has been lost worldwide through deforestation since 1990, but the rate of forest loss has declined substantially. In the most recent five-year period (2015–2020), the annual rate of deforestation was estimated at 10 million ha, down from 12 million ha in 2010–2015 (FAO, 2020).

Globally, 93% (3.75 billion ha) of the forest area is composed of naturally regenerating forests and 7% (290 million ha) is planted. The area of naturally regenerating forests has decreased since 1990, but the area of planted forests has increased by 123 million ha. The rate of increase in the area of planted forest has slowed in the last ten years (FAO, 2020).

### **Green cover enhancement**

The green cover enhancement refers to positive changes in average leaf size, leaf number per plant, plant density, species composition, and duration of green-leaf presence due to changes in growing season and multiple cropping, etc.

### **Green cover enhancement techniques**

#### **1. Reforestation**

Reforestation is defined as the restocking of felled or otherwise cleared woodland by artificial means. In other words, reforestation is the raising of a forest artificially in an area which had forest vegetation before.

#### **1.1 Objectives of reforestation**

- i. To supplement natural regeneration in the degraded forest area
- ii. To Restock the forests destroyed by fire and other biotic factors
- iii. To change the composition of the forest crop
- iv. To introduce exotics in the locality

#### **1.2 Essential preliminary considerations for reforestation**

- i. Choice of species
- ii. Selection of site
- iii. Choice of method of artificial regeneration
- iv. Spacing and
- v. Arrangement of staff

### 1.3 Choice of species

- a. The tree species are selected according to human needs such as protection, production, aesthetics, and other environmental consideration
- b. Species should have good timber, economic and other useful values
- c. Species should be adaptable to the climatic conditions prevailing in the area
- d. The soil of the region is considered while selecting species for the region
- e. Species should reduce soil erosion and improve the soil fertility
- f. It should be resistant to pest, diseases and other adverse factors
- g. It should be easily established with least cost
- h. It should be fast growing one
- i. The species should not alter the floristic composition of the forest
- j. It should not become weed in future
- k. It should not produce any allelopathic effect on other plants
- l. Selection of those species which can grow in the regional climate as well as micro-climate of the plantation site

### 1.4 Selection of site

The species environmental requirement should be matched to site with respect to climatic, edaphic condition. In addition to this, the approachability of the site, topographical conditions and wildlife considerations are taken into account while selecting a site for reforestation or afforestation.

## 2. Artificial regeneration

Artificial regeneration can be done either planting or sowing. The choice of these methods depends upon species to be raised, condition of the site and availability of seed, cost and other parameters.

### 3. Sowing

It is the process of planting seeds. It refers to the scattering or impregnating the seed over the ground for growing plants. However, good quality seeds (clean and healthy seeds) should be selected for better establishment of plantation.

#### Merits of sowing

- It consumes less time and cost
- Roots grow well without any constraints

### De-merits of sowing

- Needs huge quantity of seeds
- Weed problems is higher
- Birds and animals eat the seed sown on the surface
- Seedling mortality is higher than the direct planting
- Rate of growth of seedling is very slow and hence seedling establishment period is longer
- The opening of forest to grazing take longer time which create complications with local peoples

### Time of sowing

Time of sowing determines the successful germination and seedling establishment.

### Sowing depth

Deep as well as shallow sowing is not advisable. In case of shallow sowing, seed are liable to be eroded during watering and are liable to be eaten by birds. More precisely, seeds can be generally sown into the soil at a depth of about 2-3 times the size of the seed.

## 4. Planting

Planting refers to the act or operation of settling the seedlings in the ground for establishment of plantations and trees.

| Merits of planting                               | De-merits of planting                         |
|--|---|
| Seedling establishment and success is higher     | The cost of planting is higher                |
| Seed requirement is less                         | It requires more labour and management        |
| Seedling establishment period is shorter         | Require more knowledge and skills             |
| The forest area can be opened for grazing sooner | Transportation of seedling will be extra cost |
| Weed problem is comparatively less               | Open space alleys invite weeds                |
| The damage to seeds and seedlings is lesser      | Trampling and soil disturbance are more       |

### a. Planting time

Climate plays a deciding role in determining the appropriate planting time. Newly planted trees do best when exposed to moderate temperature and rainfall. Seedlings need time to root and acclimatize before the onset of intense heat and dryness of summer or the freezing temperatures of winter. Hence, early spring or onset of monsoon is the best time for planting. In case of localities having severe winter, it is better to plant before the snow fall. This also varies with location to location and species to species. Planting maybe of any one of the

following kinds: a. Monsoon planting b. Pre-monsoon planting c. Winter planting d. Spring planting

**b. Planting methods**

The most common mistake when planting a tree is digging of a hole, which is both too deep and too narrow. In deep pits, roots don't have access to sufficient oxygen to ensure proper growth. In case of narrow pits, root's structure cannot expand sufficiently to nourish and properly anchor the tree. As a general rule, trees should be transplanted no deeper than the soil in which they were originally grown. The width of the hole should be at least 3 times the diameter of the root ball or container. This facilitates root establishment. Planting is done either by entire planting or stump planting and details furnished below.

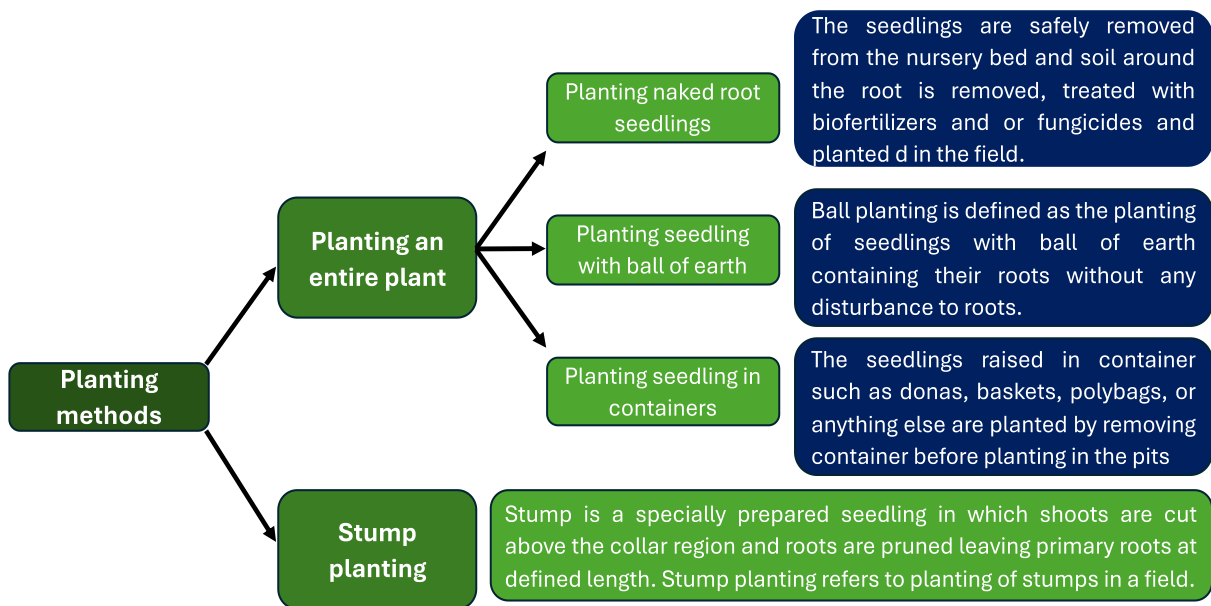

**c. Spacing**

Spacing is defined as the distance between the plants put in a plantation or standing crop. This is also referred as espacement. Based on distance between plants, spacing is classified as closer and wider spacing or high-density and low-density planting.

Factors influencing the spacing of plants:

- i. Rate of growth of species: Fast growing species needs closed spacing and vice versa.
- ii. Habit of branching: The species characteristics of having large branches and crown requires wide spacing whereas conifers need closer spacing.
- iii. Height of planting material: If the seedling height is higher, wider spacing is adopted because rapid growth of the seedlings will quickly occupy the space and help reduce weed problems.

- iv. Site factor: At better site condition, closed spacing is adopted as the site support more trees per unit area.
- v. Inter cultivation: In the case of taungya system (raising agricultural crops in between tree in forest areas) the spacing between trees should be higher than the normal. This is due to spacing for arable crop cultivation.
- vi. Market for small size timber: In areas requires demand for small woods, it is better to adopt closer spacing and vice versa.
- vii. Objectives of the production: If the objective of production is timber, wider spacing is advisable whereas for fuel wood production, closer spacing is recommended.
- viii. Cost: Based on the cost availability, spacing may be closer or wider. Closer spacing requires more cost for seedling requirement and vice versa.

**d. After care:**

- i. Beating up and weeding: sowing and planting are never cent percent successful and therefore failed places have to beaten up (i.e., resown or replanted with new planting materials). Soon after the germination starts weeds appear and have to be removed.
- ii. Fire and general protection: after weeding, the plantations require protection against grazing and fire. With the onset of summer, the plantation has to be protected against fires.
- iii. Fence: Properly fenced areas are safe for grazing; however, grazing guards must be appointed to ensure the fence remains in good repair.

**2. Afforestation**

Afforestation refers to establishment of forest by artificial means on an area from which forest vegetation has always or long been absent.

**General objective of afforestation:**

- i. To increase the forest or vegetative cover of a watershed and or of locality
- ii. To increase the domestic and industrial wood production
- iii. To meet out the needs of the increasing human needs ( fuel, fodder, small timber)
- iv. To improve the general environment
- v. To protect the agroecosystem
- vi. To protect the catchment area and conservation of soil
- vii. To reduce the pollution
- viii. To increase the aesthetics view of a landscape

## Scope

In order to increase the area under forest or tree growth within the reserved forest, sites like abandoned cultivation sites, open spaces of no specified biotic system etc., in which afforestation work can be done. Outside the reserved forest, only those land should be taken up for afforestation which are not suitable for agriculture e.g., denuded waste lands, bunds, road sides, canal banks, lands along railway lines, etc. as the difficulties of various sites are different, technique of afforestation of various sites is described separately as under:

### ► Selection of tree species for wasteland afforestation

- Adaptable to the local condition
- Short gestation period
- Good coppicing ability
- Multiple in used
- Higher demand and better commercial value
- Low cost of initial establishment
- Ability to improve the soil and fix atmospheric nitrogen
- Easy management and protection

| Waste lands type    | Species suitable  |
|---------------------|---|
| Marshy areas        | <i>Bamboo, E. grandis, T. arjuna, Acacia auriculiformis, Pongamia pinnata</i> etc   |
| Sandy areas         | <i>Acacia auriculiformis, Anacardium occidentale, D. sissoo, Melia azadirachta</i>  |
| Acids soils         | <i>Ailanthus ultisima, Albezia procera, Gliricedia sepium, Gmelina arborea</i> etc  |
| Alkaline soils      | <i>A. nilotica, A. excelsa, T. arjuna, P. juliflora, P. pallida, Salvadora persica, Tamarindus indica</i>                   |
| Saline soils        | <i>A. nilotica, A. catechu, Ailanthus excels, T. arjuna, P. juliflora, P. pallida, Salvadora persica, Tamarindus indica</i> |
| Dry clay soils      | <i>Accia nilotica, A. tortolis, Acacia lebbeck, Azadirachta indica</i> etc  |
| High altitude areas | <i>Acacia mearnsi, ailanthus altisima, Grevillea robusta</i>  |
| Dry areas           | <i>Acacia spp, P. juliflora, Z.mauritina, E. Commaldulensis</i>   |

### Techniques for afforestation of different kinds of waste lands

#### 1. Salt affected soil

The salt affected soils are classified into three categories viz; saline soil, alkaline soil and saline-sodic soil. These soils contain excess amount of soluble salt such as chlorides and sulphate that affect plant growth.

### Afforestation techniques in saline soils

**Ridge- trench method:** The trees are planted on 50 to 100 cm high ridges and trenches between the ridges are used for draining excess water. This method is suitable for coastal areas.

**Sub-surface planting in auger holes:** Planting is done at sub surface level that contains low salts. The saplings are planted in auger holes of 30-40cm deep.

**Planting in furrow cum irrigation channel:** saplings are planted at 30cm deep trenches or furrows. Reclamation measures: Soil amendments such as gypsum, organics (manures, straw) are added to improve the physical and chemical properties.

**Irrigation:** Regular irrigation with good quality water especially in initial period of establishment is needed for saline soils.

### Choice of species

- Species should tolerate high salt content in the soil
- Should have the ability to extract more salts from the soil so that in long run, it will reclaim the land.
- Suitable species for afforestation of salt affected soils are; *Tamarix ariculata*, *Zizyphus spp.*, *Salvadora spp.*, *Ailanthus excels*, *Butea monosperma*, *Terminalia arjuna*, *Sesbania spp*, *Azadirachta indica*, *Prosopis Juliflora* and *Prosopis Pallida* etc.

### 2. Acid soil

Soil having pH less than 6.5 is considered as acid soil and if pH is less than 4.5 is referred as strong acid soil. It occurs mostly in high rainfall areas due to leaching of bases from soil. It also arises due to more organic matter presence. It contains high amount of aluminium, manganese and iron, which cause toxicity to plant growth. Phosphorous availability is limited by these elements and hence it is not available to plants. In this condition, it is essential to correct the soil pH initially. For this purpose, addition of lime, basic slag, paper mill sludge is essential. This will increase the soil pH towards neutral conditions. Addition of rock phosphate is required to supply the needed phosphorous to plants. In case of planting in these sites, an ordinary pit is sufficient for planting. But while filling dug out soil is mixed with 1-2 kg of organic manures and 1 kg of lime. This mixture is used for filling the pits.



### Choice of species

Choice of species should be tolerant to acid conditions. Species suitable for these soils are, *Xylia xylocarpa*, *Ailanthus ultisima*, *Albezzia procerra*, *Gliricedia sepium* and *Gmelina arbore*.

### 3. Mined out areas

Mining refers to activities that extract ore or raw materials from earth both from surface as well as subsurface. In India, mining activities spreads over 7 lakhs ha across the country. Maximum number of mines occurs in Rajasthan, Bihar, Orissa, Madhya Pradesh, Tamil Nadu and Maharashtra.

#### Mining is of two kinds viz; open cast mining and surface mining

a) **Open cast mining:** Refers the deep excavation of earth lithosphere to get the ores and raw materials.

##### *The Characteristics feature of open cast mining:*

- High rock temperature
- Presence of explosive gases
- Presence of noxious fumes
- Out bursts of toxic fluids
- Unpredictable rock behaviour
- Interference of subterranean water course

b) **Surface mining:** Refers to the excavation of minerals and ores from the surface of earth itself.

##### *Impact of mining and quarrying*

1. Extensive damage to surface land
2. Destruction of flora and fauna
3. Left ugly scar
4. Shifting of towns, roads, railways etc
5. Depletion of ground water table
6. Diversion of forest and agricultural lands
7. Effect on human habitat and eco-balance
8. Massive disfiguration of landscape

***Problems related to revegetation of mine spoils***

1. Salinity and acidity
2. Inadequate supply of nutrients
3. Severe soil erosion
4. Bulk density is less than (10-20%) the original soils
5. Low infiltration rate and porosity

**Afforestation measures**

The pit size is kept 45cm<sup>3</sup> or 60cm<sup>3</sup> at a spacing of 2m x 2m. This is made on trenches of 2m x 60cm x 30cm in sloppy areas. The number of trenches per ha is 200 to 250. Soil conservation work is done wherever necessary to arrest the soil erosion. The pits are filled up with good soil and planted after onset of monsoon. Watering, weeding and initial care is done for first 2-3 years till trees establish safely.

**Choice of species**

The choice of species should be made according to the agro-climatic zone. The local species should be given preference.

- Trees: *Pinus caribaea*, *Cassia*, *Accacia auriculiformis*, *Eucalyptus camaldulensis*, *Dalbergia sissoo*, *Albizia* spp, *Acacia catechu*, *Grevillia robusta*, *Acacia nilotica*, *A. lebbbeck*, *A. amara* etc.
- Legumes: *Clitoria ternatia*, *Desmanthus virginatus*, *Stylosanthus hamata*
- Grass: *Cenchrus seticus*, *Desmodium strictus*
- Crops: *Cajanus cajan*, *Pennisetum typhoides*, *Phaseolus aurens*.

**4. Shifting sand dunes and inland sands**

These lands are distributed in Rajasthan, Haryana and Punjab and parts of Tamil Nadu. These soils have low fertility due to poor structure, low clay content, low biological activity, poor organic matter content and moisture.

**Afforestation measures:** The afforestation work comprises of

- (a) Sand dunes fixation and stability through micro wind breaks,
- (b) Creation of wind breaks and shelterbelts and
- (c) Development of fuel and fodder blocks.

The micro wind breaks are erected by planting twigs of trees and brush woods. These are planted at definite spacing in a check board pattern. Planting is carried out after onset of monsoon. In the first 6-8 waterings are needed and a minimum of 3 waterings should be carried

out in the second year. Fencing and weeding are done if necessary. The shelterbelts and windbreaks are created by planting hardy and fast growing species. Above all, the success depends on the control of grazing and other biotic factors.

**Choice of species:** The species selected for afforestation of dunes must be drought resistant and having well developed root system. The tree should be able to penetrate deep into the soil for moisture and nutrient uptake. The root system should be multi-layered. The species can withstand high temperature and severe frost. The species should be a good coppice and should be able to provide firewood, posts fodder, etc.

**Trees:** *Prosopis juliflora*, *P.cineraria*, *Azadirachta indica*, *Tecomella undulata*, *Salvadora oleoides*, *Acacia albida*, *Acacia tortilis*, *Acacia senegal*.

**Shrubs:** *Callygonum polygonoides*, *Zizyphus nummularia*

**Grasses:** *Lasiurus syndicus*, *Cenchrus ciliaris*, *C. setigerus*, *Dichanthium annulatum* and *Panicum antidotal*.

## 5. Laterite Lands

Laterite lands are the kinds of acid soils which occur mostly in high rainfall areas and upper ridges. These soils lack silicon due to leaching of silicon from the upper soil. But these soils accumulates higher amount of iron and aluminium (sesquioxides). Besides this, it lacks humus and organic matter resulting in poor soil fertility. Afforestation of these lands needs making of contour trenches in specified interval based on the sloped conditions. Between these trenches, pits of 30 or 45 cm<sup>3</sup> are made for planting. In these pits dug up earth is arranged as ridges on lower side. Additional of organic manure and fertilizers such as urea, super phosphate is also needed for better supply of nutrients to the seedlings planted.

### Choice of species

Suitable species for laterite soils are *Tectona grandis*, *Dendrocalamus strictus*, *Eucalyptus*, *Pterocarpus maximum*, *Shorea robusta*, *Xylia xylocarba*, *Anogeissus latifolia*, *Adina cardifolia*, *Cleistanthus collinus*, *Anacardium occidentale*, *Santalum album* etc.

## 6. Denuded and Eroded Hill Slopes

### Characteristics

- Little cover of vegetation
- Most of the vegetation is heavily grazed
- Vegetation is mostly of brushes, herbs, climbers and grasses
- Soil is shallow, stony, poor moisture content and low in nutrient status

- Runoff is excessive and erosion is severe
- Grazing and illicit felling and intentional fire incidences are very high

#### **Afforestation measures:**

Afforestation and soil conservation measures should be taken simultaneously. Soil and moisture conservation work is first carried out. It is most essential for rejuvenation denuded hills which has shallow soil with low moisture. This ensures seedling establishment, survival, ground water recharge and reduction of erosion and runoff. Staggered contour trenches are made and the dug up soil is placed on the lower side of trench. Planting is done on the trenches suitable. Uniform spacing is not possible in places of rocky areas. Pits are made in between the contour trenches without bothering for spacing. The area should be properly fenced and closed for grazing.

The hardy species can succeed on exposed and eroded areas and hence the species planted should be deep rooted and able to produce vigorous suckers and coppice shoots.

**Temperate region:** *Pinus roxburghii*, *Pinus wallichiana*, *Celtis australis*, *Cedrus deodara*.

**Moist sub-tropical region:** *Pinus cassia*, *Pterospermum acerifolium*, *Manikara hexandra*, *Phoenix* spp, *Machilus* spp.

**Dry sub-tropical region:** *Acacia modesta* , *Dodonea viscosa* , *Robinia pseudocacia* , *Prosopis juliflora* , *Tectona grandis*, *Gmelina arborea*, *Eucalyptus*.

**Tropical region:** *Acacia nilotica*, *A. catechu*, *A. siamea*, *Albizia* spp, *Dendrocalamus strictus*, *Tamarindus indica* , *Dalbergia sissoo*, *Azadirachta indica* , *Eucalyptus hybrid*

### **7. Dry lands**

The lands received rainfall less than 700 mm is considered as dry lands. The main constraint in dry lands is deficiency of moisture to plants. Erosion is heavier due to presence of poor vegetation in these areas. The soils are usually saline or alkaline due to the deposition of salts in the upper soils. As a result afforestation works mainly concentrates on soil and moisture conservation approaches. The soil working includes contour trenches and staggered trenches of size 3.5 cm x 60 cm x 45 cm at a spacing 11m x 11m. Species selection is made according to the local needs. The species recommended are *Eucalyptus teriticornis*, *Dendrocalamus strictus*, *Melia*, *Azadirachta*, *Acacia catechu*, *Prosopis juliflora* and *Azadirachta indica*.

### **8. Rock out crops land**

These lands are resulted due to severe soil erosion. Soils are almost nil except certain crevices and low depressions. Even these soils are mostly of gravelly nature. Hence afforestation of these lands is more difficult and involves huge cost. Afforestation of these lands needs soil

import from valleys .Whenever crevices are available, soil is filled and planting is done. Trenches also made in suitable places and filled with loam soil before planting .Pioneer otherwise termed as hardy plant species is the ideal selection for these lands .Few such species are *Sterculia urens*, *Cactus*, *Prosopis juliflora*, *Annona squamosa* etc.

### 9. Gullied and ravine lands

These lands are severely eroded by water. Here soil depth is limiting factor besides devoid of organic matter content. As a result, soil fertility is poor in these lands. Vegetation is also poor. Afforestation of these lands needs three level approaches. First catchment areas of these ravines and gullies are to be addressed suitably. Contour bunds are constructed at suitable intervals. Wastelands near ravine are afforested. Gully plugging is to be carried out wherever is necessary. In the second step, slope head and ravine slope is addressed. Then staggered trenches of suitable size are made at an interval of 3-4.5 m and after every fifth line, one continuous contour trench is made. Finally, valley needs to be attempted. Here continuous trench is made with a size of 60cm x 45cm at every 3m interval. Peripheral bunding for controlling the upward progression of gully head.

#### *Species suitable for different slop positions*

| Slope positions       | Species suitable   |
|-----------------------|--|
| Slope head, flat tops | <i>Dalbergia sissoo</i> , <i>Albizia lebbeck</i> , <i>Prosopis juliflora</i> , <i>Acacia catechu</i> , <i>Pongamia pinnata</i> etc                     |
| Eroded slopes         | <i>Prosopis juliflora</i> , <i>Acacia nilotica</i> , <i>Aalbizzia lebbeck</i> , <i>grasses and legumes</i>   |
| Valley bottoms        | <i>Morus alba</i> , <i>Dendrocalamus strictus</i> , <i>Gmelina arborea</i> , <i>Dlbergia sisoo</i> , <i>Sizygium cumini</i> , <i>Terminalia arjuna</i> |
| Gully head control    | <i>Balanites aegyptiaca</i> , <i>Agave americana</i> , <i>A. sislana</i> , <i>Ailanthus excelsa</i> , <i>Vitex negundo</i> , <i>Randia spinosa</i> etc |

### 3. Agroforestry

#### What is agroforestry?

The World Agroforestry Centre defined agroforestry in simple terms as agriculture with trees. FAO defined agroforestry as a collective name for land-use systems and technologies where woody perennials (trees, shrubs, palms, bamboos, etc.) are deliberately used on the same land-management units as agricultural crops and/or animals, in some form of spatial arrangement or temporal sequence. In agroforestry systems there are both ecological and economical interactions between the different components. Agroforestry can also be defined as a dynamic, ecologically based, natural resource management system that, through the integration of trees on farms and in the agricultural landscape, diversifies and sustains

production for increased social, economic and environmental benefits for land users at all levels ([www.icraf.cgiar.org](http://www.icraf.cgiar.org)). In particular, agroforestry is crucial to smallholder farmers and other rural people because it can enhance their food supply, income and health. Agroforestry systems are multifunctional systems that can provide a wide range of economic, sociocultural, and environmental benefits.

### Types of agroforestry systems

There are three main types of agroforestry systems:

1. **Agrisilvicultural** systems are a combination of crops and trees, such as alley cropping or homegardens.
2. **Silvopastoral** systems combine forestry and grazing of domesticated animals on pastures, rangelands or on-farm.
3. **Agrosylvopastoral**: the three elements, namely trees, animals and crops, can be integrated in what are called agrosylvopastoral systems and are illustrated by homegardens involving animals as well as scattered trees on croplands used for grazing after harvests

### Components of agroforestry

The three main components of agroforestry are animals, crops and trees which can be combined in numerous spatial and temporal arrangements and for different functions, creating thus many different kinds of systems. The definitions of the systems described below are sourced from P.K. Ramachandran Nair's "An Introduction to Agroforestry." The author, co-founder of the World Agroforestry Centre (ICRAF) in 1993, is a pioneer in the establishment modern agroforestry.

### Agrisilvicultural systems (trees combined with crops)

|   |   |  |
|---|---|--|
| <b>Improved fallows:</b>                        | : | Woody species planted and left to grow during fallow.  |
| <b>Taungya:</b>                                 | : | Combined stand of woody and agricultural species during early stages of establishment of plantations.  |
| <b>Alley cropping (hedgerow intercropping):</b> | : | Woody species in hedges; agricultural species in alleys in between hedges; microzonal or strip arrangement.  |
| <b>Multilayer tree gardens</b>                  | : | Multispecies, multilayer dense plant associations with no organized planting arrangements.   |
| <b>Multipurpose trees on crop lands:</b>        | : | Trees scattered haphazardly or according to some systematic patterns on bunds, terraces or plot/field boundaries.  |
| <b>Plantation crop combinations:</b>            | : | Such as integrated multistorey mixtures of plantation crops; of plantation crops in alternate; shade trees for plantation crops; shade trees scattered; intercropping. |

|  |   |   |
|--|---|---|
| <b>Home gardens:</b>                               | : | Multistorey combination of various trees and crops around homesteads.                             |
| <b>Trees in soil conservation and reclamation:</b> | : | Trees on bunds, terraces, raisers, etc. with or without grass strips; trees for soil reclamation. |
| <b>Shelterbelts and windbreaks, live hedges:</b>   | : | Trees around farmland/plots.  |
| <b>Fuelwood production:</b>                        | : | Interplanting firewood species on or around agricultural lands.                                   |

### Silvopastoral systems (trees and pastures or animals)

|  |   |  |
|--|---|--|
| <b>Trees on rangeland or pastures:</b>             | : | Trees scattered irregularly or arranged according to some systematic pattern.                  |
| <b>Protein banks:</b>                              | : | Production of protein-rich tree fodder on farm/rangelands for cut-and-carry fodder production. |
| <b>Plantation crops with pastures and animals:</b> | : | For example, cattle under coconuts in south-east Asia and the south Pacific.                   |

### Agrosilvopastoral systems (animals, trees and crops)

|                                       |   |   |
|---------------------------------------|---|---|
| <b>Homegardens involving animals:</b> | : | Intimate, multistorey combination of various trees and crops, and animals, around homesteads. |
| <b>Multipurpose woody hedgerows:</b>  | : | woody hedges for browse, mulch, green manure, soil conservation, etc.                         |
| <b>Apiculture with trees:</b>         | : | Trees for honey production.   |
| <b>Aquaforestry:</b>                  | : | Trees lining fish ponds, tree leaves being used as 'forage' for fish.                         |

### Scope of Agricultural Engineering in Agroforestry

Agroforestry is a component of landscape designing and conceptual landscape engineering working towards conserving the soil and water and *vis -a vis* biodiversity conservation in agricultural landscapes. There exists a greater scope agriculture engineering discipline because agroforestry integrates multiple natural components and is at the crossroads of tradition and modernity; it necessarily brings together people from diverse fields of knowledge: agronomists, animal care specialists, landscape planners and designers, foresters, economists, soil analysts and many more. This diversity of disciplines is certainly a strength, but its complexity also represents a challenge, notably in terms of coordination and communication. Many different words are used to express realities that connect to each other. Terms like climate-smart agriculture and agroecology both incorporate a wide array of practices, and among them is agroforestry. Some practices, such as permaculture, have found a voice in grassroots organizations. In other instances, the emphasis is on integrating trees in agricultural systems, as is the case for evergreen agriculture. These systems all represent a

commitment to bringing sustainable development principles to agricultural production. As trees are a fundamental component of many ecosystems, their integration in various farming practices doesn't come as a surprise.

### **Agroforestry in soil and water conservation**

Across the globe, about 75 billion tonnes of soil lost annually (GSP, 2017) where agricultural land contributed significantly with erosion rate varying from 13 to 40 Mg h<sup>-1</sup> year<sup>-1</sup> (Pimentel & Kounang, 1998). Some studies highlighted that annually about 10 Mha of agricultural lands are becoming unproductive due to soil erosion (Nyawade et al., 2018a, b). Therefore, strategies to minimize soil erosion by adopting various preventive measures are the pressing need of the day (Mandal & Tripathi, 2009; Bhattacharyya *et al.*, 2011). Agroforestry interventions play a very critical role to achieve higher production while conserving soil and water resources. Tree–crop combinations in agroforestry systems have many advantages to reduce the erosive action of rainfall and increase the infiltration rates that subsequently help in reducing the erosion.

### **Role of agroforestry in soil and water conservation**

Of late, incorporating trees on the farmlands has been given impetus to get multiple products (fodder, fuel, timber, fiber, and fruits) on one hand and resource conservation (soil, water, and environment) on the other. Trees and annual crops in agroforestry through better canopy cover, surface litter, and roots help in the conservation of soil and water.

#### **1. Soil conservation**

The combination of trees perennial (trees) and annual components (agricultural crops) in agroforestry reduces runoff, soil loss, and nutrient loss by binding the soil particles and enhancing infiltration by tree roots. Better soil moisture regimes are observed under well-managed agroforestry systems (Lal, 1989; Young, 1990; Kaushal et al., 2016). Canopy cover reduces the rainfall energy by interception and helps in reducing the impact to dislodge soil particles (Young, 1990). The rainfall interception, however, depends on morphological character (leaf shape and orientation, leaf area index and bark roughness), tree architecture and thus varies from species to species. The results obtained from various studies indicate variation in canopy interception in different tree and bamboo species ranged from 9.2% to 47% of rainfall (Table 1). Monocot species like bamboo and grasses due to fibrous root systems have been found very effective in checking soil erosion as compared to conifers and hardwood trees (Rao et al., 2012; Kaushal et al., 2020a, b).



A meta-analysis conducted by Kuyah et al. 2019, in the African region revealed that agroforestry performs 5 and 10 times better than control plots in checking runoff and soil loss. The conceptual framework depicting the role of agroforestry in controlling soil erosion is given in Fig. 1, which reveals the effectiveness of agroforestry in checking soil erosion.

The susceptibility of soil to erosion reduces as roots of trees in agroforestry bind soil particles. As compared to coarse roots, fine roots of less than <2 mm diameter have high potential to prevent soil erosion due to higher soil binding capacity (Li et al., 1991; Gyssels et al., 2005). Root's contribution toward the reduction of erosion is dependent on root architecture and species (de Baets et al., 2007; Reubens et al., 2007). The importance of roots is more in fodder and fuelwood species where the branches are removed regularly. A negative exponential relationship has been reported by Gyssels et al. (2005) between vegetation cover and erosion/ runoff rates. They also reported the relationship between erosion and root parameters as negative for varied environmental conditions (Table 2). However, a linear decline of runoff with increased vegetation cover has also been reported (Branson & Owen, 1970; Kainz, 1989; Greene et al., 1994).

**Table1. Effect of different trees species on rainfall partitioning**

| Forest type   | Interception (%) | Stemflow (%) | Throughfall (%) | References   |
|---|------------------|--------------|-----------------|--|
| Sal   | 17.7–25.3        | 2.16         | 80.2            | Negi et al., 1998; Dabral and Subha Rao, 1968                                      |
| <i>Pinu sroxburghii</i>                             | 22.1–32.4        | 0.31         | 66.5            | Dabral and Subha Rao, 1968   |
| <i>Tectona grandis</i>                              | 16.0–20.8        | 8.2          | 75.7            | Anand et al.,2020; Dabral and Subha Rao, 1968;                                     |
| <i>Anthocephalus cadamba</i>                        | 13.5             | 10.1         | 76.4            | Anand et al.,2020;   |
| <i>Melia azedarach</i>                              | 11.8             | 8.5          | 79.7            |  |
| <i>Terminalia bellirica</i>                         | 9.5              | 9.3          | 81.1            |  |
| <i>Quercus leocotrichophora</i>                     | 14.8–20.1        | 0.44–5.6     | 79.2–84.7       | Pathak et al., 1985, Mehra et al., 1985; Loshali and Singh,1992; Negi et al., 1998 |
| <i>Morusalba</i>                                    | 9.2–14.9         | 4.5–10       | 80.8–85.1       | Kaushal et al. (2017)  |
| <i>Bamboos (different sympodial bamboo species)</i> | 12–47            | 7–22         | 43–72           | Kaushal et al. (2021); Rao et al. (2012)   |
| <i>Acacia nilotica</i>                              | 26.0             |              |                 | Mathur et al. (1975)   |

|                                     |       |        |         |  |
|-------------------------------------|-------|--------|---------|--|
| <i>Acacia catechu</i>               | 28.5  |        |         | Dabral et al., 1963  |
| <i>Eucalyptus (Bluegum)</i>         | 21.9  |        |         | Samraj 1982  |
| <i>Evergreen beech (Nothofagus)</i> | 29.0  | 2.0    | 69.0    | Rowe, 1983   |
| <i>Fagus sylvatica</i>              | 14–29 | 1–20.4 | 61.6–83 | Giacomin and Trucchi, 1992; Tarazona et al., 1996; Neal et al., 1993; Didon-Lescot, 1998 |
| <i>Acacia mangium</i>               | 25.6  | 2.7    | 73.1    | Park and Cameron, 2008   |
| <i>Gliricidia sepium</i>            | 13.5  | 1.5    | 86.9    |  |
| <i>Guazuma ulmifolia</i>            | 9.2   | 2.3    | 89.3    |  |
| <i>Ochroma pyramidale</i>           | 15.7  | 0.9    | 84.0    |  |
| <i>Pachira quinata</i>              | 11.2  | 1.3    | 87.7    |  |

To enhance production, stabilize land, control soil erosion and sediment agroforestry measures are proven effective. Many countries such as India, Sumatra Java, Kenya, Philippines, and Nigeria have got success in soil erosion control by the use of agroforestry (Lal, 1989, 1990; Young, 1997). Such agroforestry practices can withstand extreme climatic conditions like drought, extreme temperatures, prolonged inundation, acidity, high alkalinity, and varied soil conditions. In India, under various developmental programs and schemes like community forestry, rural development and protection forestry-related activities like watershed development, desert development, soil water conservation/flood control, multipurpose river valley projects, agroforestry is an important component.

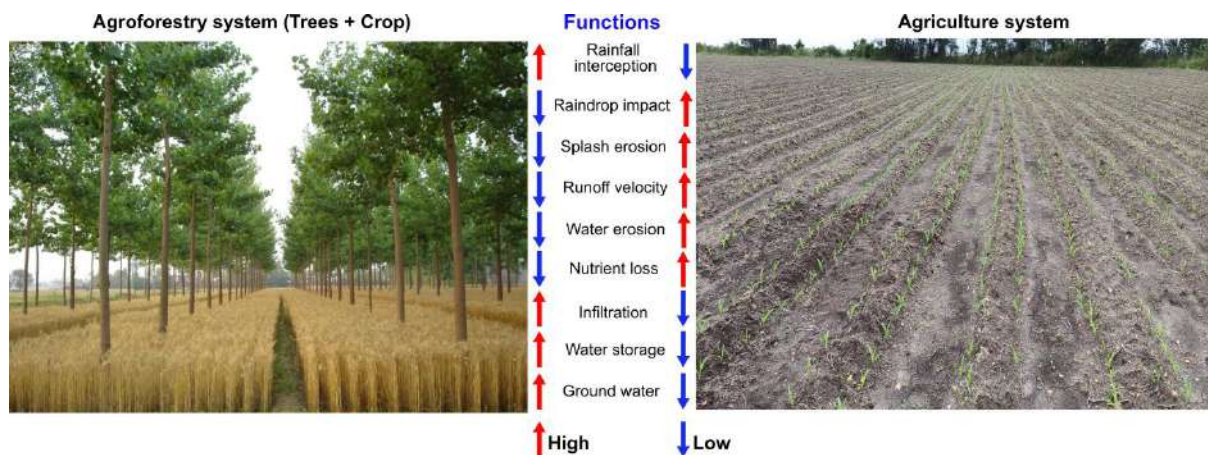

Fig. 1: Conceptual framework depicting the role of agroforestry in controlling soil erosion.

**Table. 2. Relationship of runoff/soil loss/soil erosion with vegetation cover/root density.**

| Equations            | Parameters meaning  |
|----------------------|---|
| $SL_r = e^{-bC}$     | SL <sub>r</sub> = relative soil loss (or soil loss under a specific vegetation cover compared to the soil loss on a bare surface),<br>C=vegetation cover (%), and b=a constant which varies between 0.0235 and 0.0816 according to the vegetation type and land conditions.   |
| $R_r = e^{-bC}$      | R <sub>r</sub> =runoff (R <sub>r</sub> ) C = vegetation cover (%), and b = a constant, where b values range from 0.0103 to 0.0843 according to land conditions.   |
| $SEP = e^{(-bC)} RP$ | SEP = is the soil-erosion parameters (inter-rill or rill erosion rates of bare top soils without roots), RP is root density (kg m <sup>-3</sup> ) or root-length density (km m <sup>-3</sup> ), and b is a constant that indicates the effectiveness of plant roots in reducing soil erosion rates. The value of b varies from zero for splash erosion and 0.1195 for inter-rill erosion when root density is used as a root parameter. The value of b is 0.0022 when root-length density is taken. For rill erosion, the average b values are 0.5930 and 0.0460, respectively. |

## 2. Water conservation

Trees in agroforestry take care of both excess water and water scarcity during drought periods (Bhattacharyya et al., 2007). The soil moisture in agroforestry is improved due to shade from the tree canopy which helps in changing the microclimate by lowering the air and soil temperatures thereby leading to, reduction in evaporation from the soil and transpiration from the annual crops (Rhoades, 1995; Siriri et al., 2013). Tree roots also enhance soil hydraulic properties as compared to crops due to a greater proportion of larger pores created by tree roots (Cadisch et al., 2004). Soil physical properties viz., bulk density, porosity, water holding capacity, and infiltration of the soil are significantly improved due to the addition of fine roots by the trees (Li et al., 1992; Young, 1997; Nyamadzawo et al., 2003, 2007, 2012; Makumba et al., 2006; Ekpo & Asuquo, 2012). The trees in agroforestry utilize the soil moisture from deeper soil layer during moisture stress period due to their deep root systems. A large proportion of rainfall reaches to the ground through stemflow that increases water absorption and reduces splash erosion. This stemflow contribution maintains high soil moisture in tree root zone and leads to the addition of soil moisture at lower soil depths (Rao

et al., 2012). However, the contribution of stemflow is largely dependent upon leaf shape and orientation, tree species, crown size, branch angle, and bark roughness (Kaushal et al., 2017). Kuyah et al. (2019) reported that infiltration is more affected by agroforestry as compared to soil moisture. This is because soil moisture content varies with the uptake and transpiration capacity of trees.

A meta-analysis conducted by Kuyah et al. (2019) in 12 countries revealed that soil moisture content and infiltration improved in agroforestry compared to control. Water regulation in semiarid was greatly improved as compared to humid locations under agroforestry. Hiraoka and Onda (2012) observed that quantity of root system affects the infiltration capacity that is proportional to macropore formation. In sympodial bamboos, Kaushal et al. (2020a, b), reported higher saturated soil hydraulic conductivity due to fine root production and litterfall under different bamboo species. In north-western Himalaya infiltration rates under eucalyptus, shorea, pines, teak, bamboo, and grassland were 54.0, 21.4, 12.0, 9.6, 9.6, and 7.6  $\text{cm h}^{-1}$ , respectively. Data analysis indicated twice the rate of infiltration in *Shorea robusta*-dominated watershed in comparison to agriculture-based watershed (Dhruvanarayana and Sastry, 1983).

Contrary, in many agroforestry studies, higher competition for soil moisture between trees and annual crops has been observed. However, appropriate choice of tree species and good tree management practices (root and shoot pruning, pollarding, coppicing, etc.) can be useful in reducing the soil moisture competition (Ong et al., 1996; Siriri et al., 2003; Siriri et al., 2013). Chandrashekara (2007) observed that shoot pruning was beneficial for reducing underground competition in 10 tree species in Kerala (India). Shoot pruning also helped in reducing water consumption by the trees, thereby recharging the root zone of agriculture crops (Jones et al., 1998).

### 3. Farm Forestry

Farm forestry, a term used mainly in Asia, refers to tree planting on farms. The major distinction between agroforestry and these other systems is that, while agroforestry emphasizes the interactive association between woody perennials and agricultural crops and/or animals for multiple products and services, the other terms refer to tree planting, often as woodlots.

### 4. Social Forestry

Social forestry refers to using trees and/or tree planting specifically to pursue social objectives, usually betterment of the poor, through delivery of the benefits of trees and/or tree planting to local people.

### 5. Community forestry

Community is a form of social forestry, refers to tree-planting activities undertaken by a community on communal lands or the so-called common lands; it is based on local people's direct participation in the process, either by growing trees themselves, or by processing the tree products.

### 6. Familial Forestry

Familial Forestry is a concept that integrates trees as integral members of the family, fostering societal engagement in forestry and conservation activities, contributing to the development of an ecological civilization. By considering trees as green family members, this approach encourages environmental sensitivity and empowerment, shaping individuals as environmentally connected stakeholders. The concept aims to make families climate-sensitive and proactive, incorporating rituals and festivals with trees into the social structure.

#### **Origin and history**

The Familial Forestry took its birth in 2006 and it was launched in the village, Himtasar, where 120 households were part of the pioneering pilot. Prof. Shyam Sunder Jyani is an Indian environmentalist and academic, best known for afforestation efforts in the Indian state of Rajasthan developed idea of familial Forestry. He is presently an associate professor of sociology at Dungar College, Bikaner. In recognition of his work, he was awarded the Indira Gandhi National Service Scheme Award in 2012 and later the Land for Life Award from the United Nations Convention to Combat Desertification in 2021.

In the north-western region of Rajasthan, where Familial Forestry has been implemented for over one and half decade, hundreds of thousands of students and villagers have acquired skills in proper plantation and post-plantation care. This initiative not only enhances climate awareness but also addresses issues of hunger and malnutrition by promoting the plantation of fruit plants at home. Family trees serve as nesting places for birds and insects, contributing to increased biodiversity.

### **Domain area and future scope**

Familial Forestry complements social forestry schemes by focusing on regaining ecological functioning and improving human welfare across deforested or degraded forest landscapes. Emphasising the importance of diverse native tree species, it contributes to forest landscape restoration, involving communities in mutually beneficial interventions for landscape improvement. The long-term perspective of Familial Forestry, grounded in a strong attachment to trees and the environment across generations, accelerates the accumulation of forest-related knowledge, ensuring well-being and sustainability for local communities through sustainable forest management.

Acknowledging the pressing issue of increased CO<sub>2</sub> levels in the Earth's atmosphere, Familial Forestry serves as a bottom-up approach to climate action. Directly involving communities, especially the younger generation, it has been successfully replicated in 1.6 million families across more than 18,000 villages in the arid region of western Rajasthan over the last two decades. This effort has led to the development of 200 Institutional Forests and the planting of over 4 million saplings in various forms making Familial Forestry synonymous with environmental activism in the area.

To enhance the holistic habitat healing methodology, Familial Forestry actively incorporates rituals and festivals with trees, fostering a cultural connection to nature and promoting sustainable living practices. This approach contributes to the overall well-being of ecosystems, communities, and the environment.

Familial Forestry, as a holistic environmental initiative, significantly contributes to the United Nations Sustainable Development Goals (SDGs). Specifically, Familial Forestry aligns with several SDGs, including: SDG 2 – Zero Hunger: Familial Forestry plays a role in addressing hunger and malnutrition by encouraging the plantation of fruit-bearing trees at home. This contributes to local food production, providing families with a sustainable source of fruits and enhancing overall nutrition. SDG 3 – Good Health and Well-being: By promoting the plantation of fruit-bearing trees, Familial Forestry addresses SDG 3 by combatting malnutrition and enhancing overall health. The inclusion of fruits in daily diets contributes to improved nutrition and well-being. SDG 4 – Quality Education: Through frequent visits to villages and active engagement with students, Familial Forestry imparts valuable knowledge and skills related to environmental conservation and sustainable practices. It contributes to environmental education, aligning with SDG 4. SDG 5 – Gender

Equality: Familial Forestry actively engages women as key stakeholders and champions, promoting gender equality (SDG 5). By involving women in forestry activities and decision-making processes, the initiative empowers them economically and socially, contributing to a more gender-inclusive approach to environmental conservation. SDG 12 – Responsible Consumption and Production: Familial Forestry supports SDG 12 by encouraging responsible consumption through the sustainable use of natural resources. The initiative promotes the consumption of fruits produced through local, environmentally friendly practices, aligning with the goals of responsible production and consumption. SDG 13 – Climate Action: Familial Forestry directly addresses climate change by involving communities, especially the youth, in climate action. The initiative focuses on reducing carbon emissions through tree planting, fostering climate resilience, and promoting sustainable practices. SDG 15 – Life on Land: The core of Familial Forestry lies in the restoration of degraded land and the promotion of sustainable land use practices. By actively engaging in afforestation and regenerating natural habitats, Familial Forestry contributes significantly to SDG 15, ensuring the conservation of terrestrial ecosystems. SDG 17 – Partnerships for the Goals: Familial Forestry fosters community participation, creating partnerships between local communities, educational institutions, and environmental organizations. This aligns with SDG 17, emphasizing the importance of collaboration for the achievement of sustainable development.

By addressing these SDGs, Familial Forestry emerges as a comprehensive approach that not only contributes to environmental conservation but also integrates social, economic, and educational dimensions for sustainable development.

## **7. Tree outside the forests (TOFs)**

Generally, extensive tree wealth exists outside continuous forested areas in every country, termed as ‘Trees Outside Forests’ (TOF). Recognition of this wealth by the Forest Survey of India is the big boost for promotion of tree planting activities outside the recorded forest areas and accounting their ecosystem services. Therefore, planting activities conducted in watershed level and on agricultural landscapes contributing to the green credit of the country. The different tree species recommended for agroforestry system in the various regions of the country could be used here to promote the green cover in the watershed.

## References

- Bhattacharyya, P., Mandal, D., Bhatt, V. K., & Yadav, R. P. (2011). A quantitative methodology for estimating soil loss tolerance limits for three states of Northern India. *Journal of Sustainable Agriculture*, 35(3), 276–292.
- Branson, F. A., & Owen, J. B. (1970). Plant cover, runoff, and sediment yield relationships on Mancos shale in Western Colorado. *Water Resources Research*, 6, 184–790.
- Cadisch, G., de-Willigen, P., Suprayogo, D., Mobbs, D. C., van-Noordwijk, M., & Rowe, E. C. (2004). Catching and competing for mobile nutrients in soils. In M. van Noordwijk, G. Cadisch, & C. K. Ong (Eds.), *Below-ground interactions in tropical agro ecosystems* (pp. 171–191). Boston, MA: CABI Publishing.
- Chandrashekara, U. M. (2007). Effects of pruning on radial growth and biomass increment of trees growing in homegardens of Kerala, India. *Agroforestry Systems*, 69, 231–237.
- Chen, C., Park, T., Wang, X., Piao, S., Xu, B., Chaturvedi, R. K., Fuchs, R., Brovkin, V., Ciais, P., Fensholt, R., Tømmervik, H., Bala, G., Zhu, Z., Nemani, R. R., & Myneni, R. B. (2019). China and India lead in greening of the world through land-use management. *Nature sustainability*, 2, 122–129.
- Dabral, B. G., & Subha Rao, B. K. (1968). Interception studies in chir and teak plantations in New Forest. *Indian Forester*, 94(7), 541–551.
- Dabral, B. G., Nath, P., & Swarup, R. (1963). Some preliminary investigation on rainfall interception by leaf litters. *Indian Forest*, 89, 112–116.
- de Baets, S., Poesen, J., Knapen, A., Barbera, G. G., & Navarro, J. A. (2007). Root characteristics of representative Mediterranean plant species and their erosion-reducing potential during concentrated runoff. *Plant Soil*, 294, 169–183.
- Dhruvanarayana, V. V., & Sastry, G. (1983). Annual report. Dehradun: CSWCRTI.
- Didon-Lescot, J. F. (1998). The importance of throughfall in evaluating hydrological and biogeochemical fluxes: example of a catchment (Mont Lozère, France). In: *Proceedings of the international conference on catchment hydrological and biochemical processes in changing environment*, Liblice (pp. 17–20).
- Dwivedi, A.P. 1992. *Agroforestry, Principles and Practices*. Oxford & IBH publishing, New Delhi.
- Ekpo, F. E., & Asuquo, M. E. (2012). Agroforestry practice as adaptation tools to climate change hazards in Itu Lga, Akwa Ibom State, Nigeria. *Global Journal of Human Social Science Geography and Environmental GeoSciences*, 12(11), 26–36.



- Familial Forestry <https://familialforestry.org/>
- FAO. 2015. Agroforestry. <https://www.fao.org/forestry/agroforestry/80338/en/>
- FAO. 2020. Global Forest Resources Assessment 2020 – Key findings. Rome.
- FSI. 2021. India state of forest report. FSI, Dehradun, India. p.586.
- Giacomin, A., & Trucchi, P (1992). Rainfall interception in a beech cop- pice (Acquerino, Italy). *Journal of Hydrology*, 137, 141–147.
- Greene, R. S. B., Kinnell, P. I. A., & Wood, J. T. (1994). Role of plant cover and stock trampling on runoff and soil erosion from semi– arid wooded rangelands. *Australian Journal of Soil Research*, 32, 953–973.
- GSP. 2017. Global Soil Partnership Endorses Guidelines on Sustainable Soil Management <http://www.fao.org/global-soil-partnership/resources/highlights/detail/en/c/416516/>.
- Gyssels, G., Poesen, J., Bochet, E., & Li, Y. (2005). Impact of plant roots on the resistance of soils to erosion by water: A review. *Progress in Physical Geography*, 2, 189–217.
- Hiraoka, M., & Onda, Y. (2012). Factors affecting the infiltration capacity in bamboo groves. *Journal of Forestry Research*, 17, 403–412.
- Jones, M., Sinclair, F. L., & Grime, V. L. (1998). Effect of tree species and crown pruning on root length and soil water content in semi–arid agroforestry. *Plant Soil*, 201, 197–207.
- Kainz, M. (1989). Runoff, erosion and sugar beet yields in conventional and mulched cultivation results of the 1988 experiment. *Soil Technol- ogy Series*, 1, 103–114.
- Kaushal, R., Kumar, A., Alam, N. M., Mandal, D., Jayaparkash, J., Tomar, J. M. S., et al. (2017). Effect of different canopy management practices on rainfall partitioning in *Morus alba*. *Ecological Engineering*, 102, 374–380.
- Kaushal, R., Kumar, A., Alam, N. M., Singh, I., Mandal, D., & Tomar, J. M. S. (2021). Eco– hydrological parameters in different sympodial bamboo species of Himalayan foothills, India. *Environmet Monitoring and Assesment* (Under review).
- Kaushal, R., Singh, I., Thapliyal, S. D., Gupta, A. K., Mandal, D., Tomar, J. M. S., et al. (2020a). Rooting behaviour and soil properties in differ- ent bamboo species of Western Himalayan Foothills, India. *Scientific Reports*, 10, 4966.
- Kaushal, R., Tewari, S., Banik, R. L., Thapliyal, S. D., Singh, I., Reza, S., et al. (2020b). Root distribution and soil properties under 12-year old sympodial bamboo plantation in Central Himalayan Tarai Region, India. *Agroforestry Systems*, 94, 917–932.

- Kaushal, R., Verma, A., Mehta, H., Mandal, D., Tomar, J. M. S., Jana, C., et al. (2016). Soil quality under *Grewia optiva* based agroforestry systems in western sub-Himalaya. *Range Management and Agroforestry*, 37(1), 50–55.
- Khanna, L.S. 1989. Principles and Practice of Silviculture. Khanna Bandhu, 7 Tilak Marg, Dehradun.
- Kuyah, S., Whitney, C. W., Jonsson, M., Sileshi, G. W., Öborn, I., Muthuri, C. W., et al. (2019). Agroforestry delivers a win-win solution for ecosystem services in sub-Saharan Africa. A meta-analysis. *Agronomy for Sustainable Development*, 39, 47–64.
- Lal, R. (1989). Agroforestry systems and soil surface management of a tropical alfisol II: Water runoff, soil erosion, and nutrient loss. *Agroforestry Systems*, 8(2), 97–111.
- Lal, R. (1989). Agroforestry systems and soil surface management of a tropical alfisol II: Water runoff, soil erosion, and nutrient loss. *Agroforestry Systems*, 8(2), 97–111.
- Lal, R. (1990). Soil erosion and land degradation: The global risks. In R. Lal, & B. A. Stewart (Eds.), *Soil degradation* (pp. 129–172). New York, USA: Springer-Verlag.
- Li, Y., Xu, X., Zhu, X. M., & Tian, J. Y. (1992). Effectiveness of plant roots on increasing the soil permeability on the Loess Plateau. *Chinese Science Bulletin*, 37, 1735–1738.
- Li, Y., Zhu, X., & Tian, J. (1991). Effectiveness of plant roots to increase the anti-scourability of soil on the Loess Plateau. *Chinese Science Bulletin*, 36, 2077–2082.
- Loshali, D. C., & Singh, R. P. (1992). Partitioning of rainfall by three Central Himalayan forests. *Forest Ecology and Management*, 53, 99–105.
- Luna, R.K. 1989. Plantation Forestry in India. International Book Distributors, Dehradun, Uttarakhand (India). - 509p.
- Makumba, W., Janssen, B., Oenema, O., Akinnifesi, FK, Mweta, D, Kwesiga, F, et al. (2006). The long-term effects of a gliricidia-maize intercropping system in Southern Malawi, on Gliricidia and maize yields, and soil properties. *Agriculture, Ecosystems & Environment*, 116, 85–92.
- Mandal, D., & Tripathi, K. P. (2009). Soil erosion limits for Lakshadweep Archipelago. *Current Science*, 96(2), 276–280.
- Mathur, H. N., et al. (1975). Research in soil conservation forestry. In *Soil & water conservation research*. ICAR Publication.
- Mehra, M. S., Pathak, P. C., & Singh, J. S. (1985). Nutrient movement in litter fall and precipitation components for Central Himalayan Forests. *Annals of Botany*, 55, a086887.

- Nair, P.K.R. 1993. *An Introduction to Agroforestry*. Kluwer Academic Publishers, Dordrecht, The Netherlands. 499p.
- Neal, C., Robson, A. J., Bhardwaj, C. L., Conway, T., Jefery, H. A., Meal, M., et al. (1993). Relationships between precipitation, stemflow and throughfall for a lowland beech plantation, Black wood, Hampshire, southern England: interception at a forest edge and the effects of storm damage. *Journal of Hydrology*, 146, 221–233.
- Negi, G. C. S., Rikhari, H. C., & Garkoti, S. C. (1998). The hydrology of three high–altitude forests in Central Himalaya India: A reconnaissance study. *Hydrological Processes*, 12, 343–350.
- Nyamadzawo, G, Chikowo, R, Nyamugafata, P, & Giller, KE (2007). Improved legume tree fallows and tillage effects on structural stability and infiltration rates of a kaolinitic sandy soil from central Zimbabwe. *Soil and Tillage Research*, 96, 182–194.
- Nyamadzawo, G, Nyamugafata, P, Wuta, M, & Nyamangara, J (2012). Maize yields under coppicing and non-coppicing fallows in a fallow- maize rotation system in central Zimbabwe. *Agroforestry Systems*, 84, 273–286.
- Nyamadzawo, G., Nyamugafata, P., Chikowo, R, & Giller, K.E. (2003). Partitioning of simulated rainfall in a kaolinitic soil under improved fallow- maize rotation in Zimbabwe. *Agroforestry Systems*, 59, 207–214.
- Nyawade, S. N., Karanja, N., Gachene, C., Schulte-Geldermann, E., & Parker, M. (2018b). Susceptibility of soil organic matter fractions to soil erosion under potato–legume intercropping systems in Central Kenya. *Indian Journal of Soil Conservation*, 73, 568–577.
- Nyawade, S. O., Karanja, N. N., Gachene, C. K. K., Schulte–Geldermann, E., & Parker, M. (2018a). Effect of potato hilling on soil temperature, soil moisture distribution and sediment yield on a sloping terrain. *Soil & Tillage Research*, 184, 24–36.
- Park, A., & Cameron, J. L. (2008). The influence of canopy traits on throughfall and stemflow in five tropical trees growing in a Panamanian plantation. *Forest Ecology and Management*, 255, 1915–1925.
- Pathak, P. C., Pandey, A. N., & Singh, J. S. (1985). Apportionment of rain- fall in Central Himalayan forests (India). *Journal of Hydrology*, 76, 319–332.
- Rao, B. K., Kurothe, R. S., Pande, V. C., & Kumar, G. (2012). Throughfall and stemflow measurement in bamboo (*Dendrocalmus strictus*) plantation. *Indian Journal of Soil Conservation*, 40(1), 60–64.

- Rao, B. K., Kurothe, R. S., Pande, V. C., & Kumar, G. (2012). Throughfall and stemflow measurement in bamboo (*Dendrocalmus strictus*) plantation. *Indian Journal of Soil Conservation*, 40(1), 60–64.
- Reubens, B., Poesen, J., Danjon, F., Geudens, G., & Muys, B. (2007). The role of fine and coarse roots in shallow slope stability and soil erosion control with a focus on root system architecture: A review. *Trees*, 21, 385–402.
- Rhoades, C. (1995). Seasonal pattern of nitrogen mineralization and soil moisture beneath *Faidherbia albida* (syn *Acacia albida*) in central Malawi. *Agroforestry Systems*, 29, 133–145.
- Rowe, L. K. (1983). Rainfall interception by an evergreen beech forest, Nelson, New Zealand. *Journal of Hydrology*, 66, 143–258.
- Samraj, P. (1982). Twenty-five years of research on soil and water conservation in southern hilly high rainfall regions. Ootacamund: CSWCRTI.
- Siriri, D., & Raussen, T. (2003). Agronomic and economic potential of improved fallows on scoured terrace benches in the humid highlands of Southwestern Uganda. *Agric Ecosyst Environ*, 95, 359–369.
- Siriri, D., Wilson, J., Coe, R., et al. (2013). Trees improve water storage and reduce soil evaporation in agroforestry systems on bench terraces in SW Uganda. *Agroforestry Systems*, 87, 45–58.
- Tarazona, T., Santa, R. I., & Calvo, R. (1996). Interception, throughfall and stemflow in two forest of the “Sierra de la Demanda” in the province of Burgos. *Pirineos*, 147, 27–40.
- The world agroforestry Centre. <https://www.worldagroforestry.org/>
- Young, A. (1990). In *Agroforestry for soil conservation* (pp. 276). Nairobi, Kenya: ICRAF.
- Young, A. (1997). In *Agroforestry for soil management* (2nd ed., Anand, R., Chaturvedi, S., Kumar, A., Tewari, A., Sah, V. K., Dhyani, V. C., et al. (2020). Rainfall partitioning in important multipurpose tree species of Himalayan foothills. *Tropical Ecology* (Communicated).
- [Major part of this notes adopted from: Kausha et al., 2021. Soil and water conservation benefits of agroforestry. In *Forest Resources Resilience and Conflicts* (Eds. Shit, P.K. H.R. Pourghasemi, P.P. Adhikary, G.S. Bhunia, V.P. Sati). Elsevier, Amsterdam, Netherlands and MBMA Reforestation and afforestation Manual. <https://www.cllmp.com/wp-content/uploads/2019/06/Reforestation-and-Afforestation-Manual.pdf>]

## Improved Agronomic Production Technologies for Sustainable Crop Production and Livelihood Improvement in Black and Red Soils of South India

*S L Patil<sup>1</sup> and M N Ramesha<sup>2</sup> and S. Manivannan<sup>3</sup>*

*<sup>1</sup>ICAR-IIPR, RRS, Dharwad, India, <sup>2</sup>ICAR-IISWC, RC, Ballari, India, <sup>3</sup>ICAR-IARI, Assam, India*

### Introduction

The global food system is expected to provide safe and nutritious food to a population that will likely grow from 7.6 billion people today, to nearly 10 billion by 2050. Agricultural production is under threat due to climate change in food insecure regions, especially in Asian countries. Various climate-driven extremes, i.e., drought, heat waves, erratic and intense rainfall patterns, storms, floods, and emerging insect pests have adversely affected the livelihood of the farmers. Future climatic predictions showed a significant increase in temperature, and erratic rainfall with higher intensity while variability exists in climatic patterns for climate extremes prediction. For mid-century (2040–2069), it is projected that there will be a rise of 2.2°C-2.8°C temperature in Asian countries. To address the impacts of climate change, it's essential to optimize climate-smart agricultural practices and technologies for sustainable productivity (Habib-ur-Rahman et al., 2022). Developing and transferring improved technology to farmers is crucial for increase productivity, income, and reducing poverty (Adams and Jumpah, 2021; Wossen et al., 2017). The adoption of these technologies positively affects household well-being (Ayenew et al., 2020), food security (Justice and Tobias, 2016), and incomes (Kopalo et al., 2021; Teka and Lee, 2020). Amid expanding dryland biomes in the earth (Yao et al., 2022), achieving food security through resource conservation in arid and semi-arid areas is challenging as it is controlled by many factors, such as agronomic, socio-economic, political and environmental (FAOSTAT, 2019). Among the various factors, modification of adoptive agronomic practices for efficient utilization of environmental resources is important (Teshfuhoney et al., 2023). Among the adoptive agronomic practices, modified tillage practices, contour cultivation, scooping, broad-bed and furrow system, conservation furrows, contour and graded border strips, compartmental bunding, ridges and furrows, zing terracing are widely adopted ones (Patil, 1998, Patil et al., 2013 and 2018). Mulching practices such as organic and soil mulch, dust mulch, vertical mulch, sand mulch, plastic mulch are important soil cover practices are being adopted according to the crop demand and various materials combinations are tested for their efficacy in resource conservation (Peng et al., 2019). To improve the soil conditions, adoptable crop residue management, brown manuring, gypsum application and silt application are explored

and discussed (Nalatwadmath et al., 2006). Under changing climatic temperature, rainfall and evaporation regimes, soil and water conservation measures at terrace level coupled with inter-terrace are important ones. Runoff harvesting and recycling strategies like farm ponds for supplemental irrigation, efficient surface irrigation methods like border strip, furrow irrigation, sprinkler and drip irrigation are presented. Finally, possible tools of nano technology, hydrophobic and polymers rainwater conservation measures are discussed here.

### **Tillage practices**

Tillage operations incorporate crop residues, control weeds/pests/diseases, conserve the rainwater *in-situ*, recharge soil profile, and prepare a smooth seedbed for seeds to germinate with a better root system, reduce loss of conserved soil water (secondary tillage) and its efficient utilization for enhanced the crops yield (Patil, 2013). Primary/off-season tillage carried out in Alfisols at ICRISAT and CRIDA, Hyderabad, resulted in better root development in maize and sorghum with greater yields during a drought year (43% increase) compared to a mild drought year (31% increase) and near to the normal rainfall year (24% increase) (Pathak and Laryea, 1995 and Sanghi and Korwar, 1987). In the *Vertisols* of Bijapur, India, deep tillage increased infiltration rate, decreased bulk density conserved higher soil water in the top 0.60 m soil depth, and produced better root development compared to medium and shallow tillage from sowing to harvest in winter sorghum (Table 1). The sorghum yield with deep tillage increased by 27% over medium and 57% over shallow tillage during the drought year compared to an increase in yield by 17% and 34% over medium and shallow tillage during the normal year (Patil and Sheelavantar, 2006). In *Vertisols* of Ballari, conventional tillage conserved greater rainwater and increased winter sorghum yields by 13% and 8% and sunflower yield by 21% and 33% over reduced and low tillage, respectively (Patil, 2007; Patil, 2013; Patil et al. 2013). The WUE in conventional tillage was higher by 8 to 10% in winter sorghum and 16% to 25% in sunflower over low tillage (Patil and Mishra, 2008). The Conventional tillage was more effective in increasing sorghum, sunflower and chickpea during drought year over reduced tillage red and black soils of Hyderabad, Bijapur and Ballari both at Research farm and farmer's fields (Table 2). Deep tillage with integrated management and improved crop cultivars in the *Vertisols* (farmer's fields) of Ballari increases the *rabi* sorghum, sunflower and chickpea yields varying from 23-29% over farmers practice depending on rainfall indicating the importance of improved technologies over farmers practice (Fig. 1) (Nalatwadmath, S.K. and Patil, S.L., 2010).

**Table.1: Effect of tillage practices on infiltration rate, bulk density, root growth, and grain yield of winter sorghum in the Vertisols of Bijapur, Karnataka, India**

| Tillage practices | Infiltration rate (mm h <sup>-1</sup> ) | Bulk density (Mg m <sup>-3</sup> ) | Root length (cm) | Grain yield (kg ha <sup>-1</sup> ) |             |        |
|-------------------|---|------------------------------------|------------------|------------------------------------|-------------|--------|
|                   |   |                                    |                  | Drought year                       | Normal year | Pooled |
| Deep tillage      | 9.7+0.6                                 | 1.23+0.03                          | 67.0             | 1919                               | 1835        | 1877   |
| Medium tillage    | 8.0+0.5                                 | 1.27+0.02                          | 57.6             | 1509                               | 1562        | 1635   |
| Shallow tillage   | 6.1+0.7                                 | 1.31+0.05                          | 41.7             | 1223                               | 1368        | 1296   |
| LSD (P=0.05)      | –                                       | –                                  | –                | 164                                | 186         | 103    |

Source: Patil and Sheelavantar, (2006)

**Table 2: Effect of conventional and reduced tillage on sorghum grain yield (kg ha<sup>-1</sup>) in south India under different rainfall and soils.**

| Tillage System                         | Hyderabad |           | Bijapur     |           | Ballari Black Soils |           |           |                 |           |           |
|--|-----------|-----------|-------------|-----------|---------------------|-----------|-----------|-----------------|-----------|-----------|
|  | Sorghum   |           | Sorghum     |           | Sorghum             |           |           | Sunflower       |           | Chickpea  |
|  | Red Soils |           | Black Soils |           | Research Farm       |           |           | Farmers' fields |           |           |
|  | NY        | DY        | NY          | DY        | NY                  | DY        | DY        | NY              | DY        | DY        |
| No offseason tillage/Reduced tillage   | 1950      | 993       | 1368        | 1223      | 2221                | 819       | 1010      | 1590            | 1000      | 1530      |
| Offseason tillage/Conventional tillage | 2430      | 1651      | 1835        | 1919      | 1936                | 738       | 805       | 1290            | 778       | 1245      |
| <b>Per cent increase</b>               | <b>24</b> | <b>66</b> | <b>34</b>   | <b>57</b> | <b>15</b>           | <b>11</b> | <b>26</b> | <b>23</b>       | <b>29</b> | <b>23</b> |

NY: Normal year; DY: Drought year

**Land Configuration**

After the execution of soil conservation structures in the field, it's essential to take up land smoothing in the inter-bund area to enable the rainwater to spread uniformly in the fields that it recharges the soil profile. These modified land configurations are effective *in-situ* rainwater conservation measures, particularly in low rainfall areas, and are discussed below.

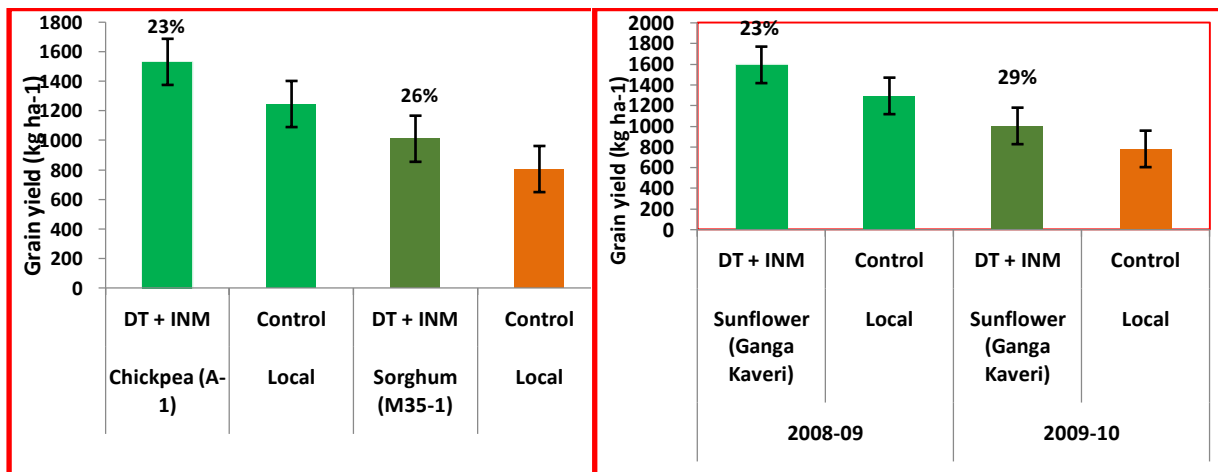

**Chickpea and Rabi Sorghum**

**Sunflower**

**Fig. 1: Deep tillage, integrated nutrient management and improved crop cultivars on crop yields in Vertisols of Ballari in the farmer's fields.**

### Contour cultivation

Contour cultivation in the red soils of the Kabbalanala watershed near Bangalore reduced runoff and soil loss conserving rainwater *in-situ*, and increasing soil moisture in the profile and crop yields of sesamum, finger millet, and groundnut over farmers' practice. The effect of contour cultivation was more felt when crops were supplemented with NPK fertilizers (Krishnappa et al., 1994 and 1999) (Table 3). Contour cultivation produced 35% and 22% higher grain yields in sorghum and setaria, respectively in black soils and 66% more grain yield in sorghum in red soils over up and down cultivation (Rama Mohan Rao et al., 1978). Contour cultivation at Ballari, India was more beneficial (92% increase in yield) than Farmer's practice during a drought year (Rama Mohan Rao et al., 2000b).

**Table 3: Influence of contour cultivation and fertilizer use on yields (t ha<sup>-1</sup>) of crops**

| Crop/cultivation practice            | No NPK               |               | Recommended NPK             |              |                     |               |               |               |
|--------------------------------------|----------------------|---------------|-----------------------------|--------------|---------------------|---------------|---------------|---------------|
| <b>Bangalore (Alfisols)</b>          |                      |               |                             |              |                     |               |               |               |
| <b>Finger millet</b>                 |                      |               |                             |              |                     |               |               |               |
| Cultivation along slope              | 0.55                 |               | 0.79 (44)b                  |              |                     |               |               |               |
| Contour cultivation                  | 0.69<br>(25) a       |               | 1.24 (89)b<br>(58) a (126)c |              |                     |               |               |               |
| <b>Groundnut</b>                     |                      |               |                             |              |                     |               |               |               |
| Cultivation along slope              | 0.57                 |               | 0.87(53)b                   |              |                     |               |               |               |
| Contour cultivation                  | 0.73<br>(28)a        |               | (55) a (137)c<br>1.35(85)b  |              |                     |               |               |               |
| <b>Ballari (Vertisols)</b>           |                      |               |                             |              |                     |               |               |               |
|                                      | <b>Drought years</b> |               |                             |              | <b>Normal years</b> |               |               |               |
|                                      | <b>Slope</b>         |               |                             |              |                     |               |               |               |
| <b>Winter sorghum</b>                | 0.5                  | 1.0           | 1.5                         | Average      | 0.5                 | 1.0           | 1.5           | Average       |
| Up and down cultivation<br>(control) | 662                  | 400<br>(-40%) | 370<br>(-44%)               | 477<br>(-)   | 1191                | 1096<br>(-8%) | 939<br>(-21%) | 1075<br>(-)   |
| Contour cultivation                  | 1213<br>(83)         | 670<br>(68)   | 864<br>(135)                | 916<br>(92%) | 1291<br>(8)         | 897<br>(-22)  | 987<br>(5)    | 1058<br>(-2%) |

Source: Krishnappa et al. (1994) -**Alfisols**: Figures in parentheses denote: a = % change over cultivation along the slope; b = % change over no NPK; and c = % change over cultivation along the slope and no NPK.

Rama Mohan Rao et al. (2000b) -**Vertisols**: Figures in parentheses denote percent increase or with negative sign indicates decrease in yield.

### Scooping

Scooping out soil to form small basins with basin listers during the second fortnight of June across the slope increases the infiltration rate and reduces soil erosion thus helping to retain rainwater on the surface that recharges the soil profile in medium to deep black soils with poor infiltration. A study conducted at ICRISAT (Pathak and Laryea, 1995) revealed that the scoops reduced seasonal runoff by 69% and soil loss by 53% and increased the pearl millet grain yield by 35% when compared to the flat land surface.



### Broad-bed and Furrow System

A raised land configuration “Broad-bed and furrow” (BBF) system with an implement called “Tropicultor” developed by ICRISAT acts both as a disposal system during high-intensity rains and as a conservation measure during low rainfall situations in the same cropping season on black soils for sustaining crop yields under vagaries of monsoon varying from 500 to 1300 mm (Pathak et al., 2009). The BBF system consists of a raised flatbed approximately 95 cm wide and a shallow furrow about 55 cm wide and 15 cm deep across the slope on a grade of 0.2 to 0.6% for optimum performance and once formed can be maintained for 25-30 years. This will save considerable costs as well as improve soil health and suitable for narrow-spaced row crops. Even if a few rows are lost due to the furrow, the yields are made up due to better *in-situ* rainwater conservation. The performance of different bedding systems, i.e., flatbed (FB), BBF, narrow bed and furrow (NBF), and raised-sunken bed (RSB), was studied in black soils at Indore and results indicated that the maximum maize yields ( $2.01 \text{ t ha}^{-1}$  and water use efficiency of  $8.81 \text{ kg ha}^{-1} \text{ mm}^{-1}$ ) were observed in the BBF system followed by the RSB and FB systems. In Vertisols of Ballari, the bedding system proved effective in conserving the rainwater, increasing the soil water in the profile, and producing 24% higher winter sorghum grain yield and safflower yield was 8% higher as compared to flat sowing (Average of 8 years). The BBF with residue incorporation conserved rainwater *in-situ*, increased groundnut yields (rainy season) and rapeseed (postrainy season), and produced greater returns with a higher B:C ratio in the northeast hill (NEH) region of India (Kuotsu et al., 2014). At Bijapur, BBF produced 8.5% runoff as against the normal sowing (15.6% runoff) and yields with 15.2% increase in *rabi* sorghum yields.

### Contour/graded border strips

Border strips of 20-30 cm height bunds are formed at regular intervals of 10 to 40 m depending upon slope with 0.1 to 0.2% grade and are more suited on lands having < 2% slope. Generally, border strips of 60 m in length at 10 m intervals are recommended. In the black soils of P.C. Pyapili watershed in Anantapur district of Andhra Pradesh, graded border strips conserved the rainwater, recharged the soil profile, reduced the runoff and soil loss, and increased the yields of sunflower and winter sorghum by 23 and 25%, respectively with greater yields during drought year compared to the normal year (**Table 4**). When border strips were supplemented with terrace level measures i.e. graded bunds, the yields of sunflower and sorghum increased further up to 38 and 42%, respectively (Patil et al., 2004).

**Table 4: Effect of rainwater conservation practices on crop yields (kg ha<sup>-1</sup>) in the watershed.**

| Treatment                      | 1999–2000             |                        | 2000–2001             |                       | Pooled                |                       |
|--------------------------------|-----------------------|------------------------|-----------------------|-----------------------|-----------------------|-----------------------|
|                                | Sunflower             | Sorghum                | Sunflower             | Sorghum               | Sunflower             | Sorghum               |
| Control                        | 626                   | 910                    | 474                   | 450                   | 550                   | 680                   |
| Graded bund alone              | 702 (12%)*            | 1012 (11%)*            | 529 (12%)*            | 530 (18%)*            | 616 (12%)*            | 771 (13%)*            |
| Border strips +<br>Graded bund | 888 (42%)*<br>(26%)** | 1274 (40%)*<br>(26%)** | 631 (33%)*<br>(19%)** | 655 (45%)*<br>(24%)** | 760 (38%)*<br>(23%)** | 965 (42%)*<br>(25%)** |

Source: Patil *et al.* 2004;\* Figures in parenthesis indicate % increase over control;\*\*Figures in parenthesis indicate % increase over Graded bund alone

### Compartmental bunding

Compartmental bunds of cross section 0.06 m<sup>2</sup> with a bottom width of 0.5 m, top width of 0.1 m, height of 0.2 m, and side slope 1:1 are formed using tractor/bullock drawn bund former during late summer in red soils and in the rainy season (June) in Vertisols in farmers' fields. The size of compartments to be farmed in farmers' fields is 10 m × 10 m for a field slope up to 2-2.5% with a cost Rs. 3000/- per ha (Fig. 2). Compartmental bunds are retained up to first week of September in cereals and oilseeds that are sown during 2<sup>nd</sup> fortnight of September and up to 3<sup>rd</sup> week of September for pulses that are sown during 1<sup>st</sup> week of October. Compartmental bunds provide a greater opportunity time for rainwater to infiltrate into the soil and wet the soil profile completely for early sowing of winter crops thus producing greater crop yields. In Vertisols of Bijapur, compartmental bunding conserved more rainwater and produced 23% higher winter sorghum yield over flat sowing (Patil and Sheelavantar, 2004). In Vertisols at Ballari, compartmental bunding increased sorghum yields by 17% and WUE by 13% over flatbed (Patil, 2003). Adoption of compartmental bunding in Vertisols at Vijayapura, India in *Rabi* sorghum, sunflower, safflower, and chickpea produced higher yields by 40, 35, 38, and 50%, respectively. The effect of compartmental bunding on crop productivity was greater during a drought year compared to normal rainfall situations both at Vijayapura and Ballari. The Compartmental bunding produced greater net returns and B:C ratio over the farmer's practice of flat planting (Table 5). (Umarfarooque Momin *et al.*, 2021). Adoption of compartmental bunding with recommended rate of nutrients through integrated nutrient management improved the plant growth and resulted in higher crop yields varying from 25-34% in chickpea, 30-33% in sunflower and 34% in *rabi* sorghum (Fig. 3) (Anon, 2010).

**Table 5: Impact of compartmental bunding on various crops**

| Technology            | Yield (kg ha <sup>-1</sup> ) | Net returns (Rs. ha <sup>-1</sup> ) | B:C ratio |
|-----------------------|------------------------------|-------------------------------------|-----------|
| <i>Rabi Sorghum</i>   |                              |                                     |           |
| Compartmental bunding | 1305                         | 17490                               | 2.88      |
| Farmers' practice     | 932                          | 9582                                | 2.37      |
| <i>Sunflower</i>      |                              |                                     |           |
| Compartmental bunding | 1013                         | 18315                               | 2.86      |
| Farmers' practice     | 690                          | 8610                                | 2.23      |
| <i>Safflower</i>      |                              |                                     |           |
| Compartmental bunding | 930                          | 22230                               | 3.12      |
| Farmers' practice     | 734                          | 15741                               | 2.80      |
| <i>Chickpea</i>       |                              |                                     |           |
| Compartmental bunding | 413                          | 563                                 | 1.55      |
| Farmers' practice     | 413                          | 563                                 | 1.55      |



**Tractor drawn bund former**



**Compartmental bunding**

**Fig.2: Compartmental bund layout in farmers' fields during June in Vertisols**

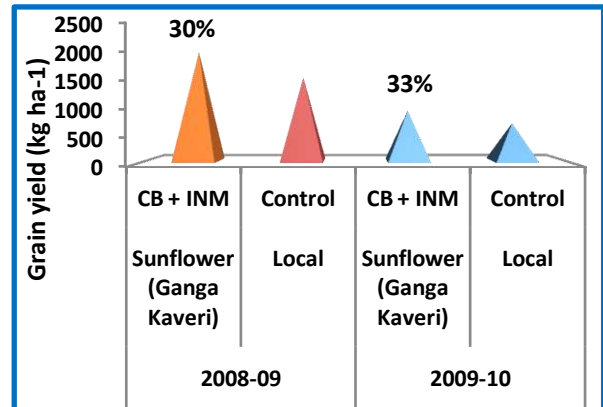
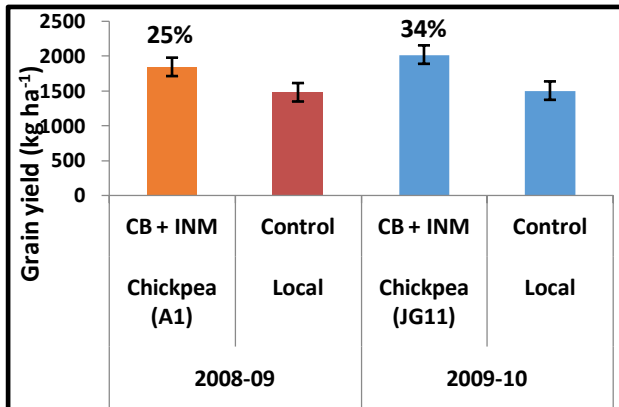

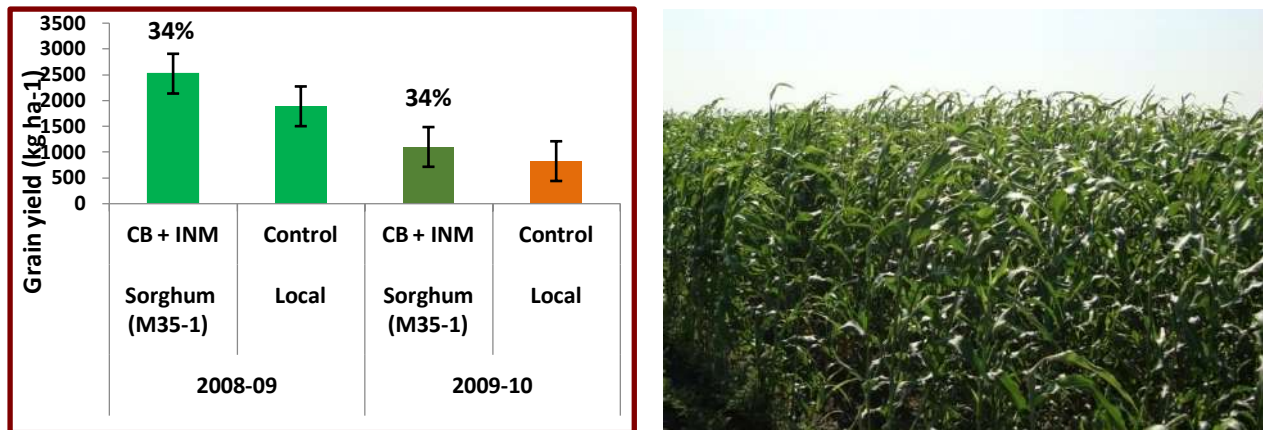

Fig. 3: Compartmental bunding with integrated nutrient management on crop yields of chickpea, sunflower and *rabi* sorghum in Vertisols (Farmer's fields) of Ballari and Kurnool districts.

### Ridges and furrows

Cultivation of crops under ridge and furrow system across the major land slope with a gradient of 0.2 to 0.4% in land having a 1 to 3% slope will conserve more rainwater *in-situ*. This is suitable for widely spaced crops with 60 cm or more row spacing. A field length of 60 to 90 m is optimum for the cultivation of crops with ridges and furrows. In *Vertisols* of Ballari, ridges, and furrows were more effective in the conservation of rainwater and increased winter sorghum grain yield during a drought year (36%) compared to a normal year (16%). Sunflower seed yield also was higher by 21 and 24% and water use efficiency was greater by 11 and 21% at the Research Farm and farmers' fields, respectively (Patil et al., 2013). Even ridges and furrows increased the WUE of winter sorghum by 16% over flat sowing. Similarly, at Bijapur, India, the formation of ridges and furrows in *Vertisols* conserved more rainwater *in-situ* and produced 26% higher winter sorghum grain yields and 25% greater water use efficiency over flat sowing (Patil and Sheelvantar, 2004). Tied ridging in the *Vertisols* of Bijapur was more beneficial in normal rainfall and drought years with 45% higher yields of pigeonpea whereas during the above-normal years yield increase was marginal (8%) due to water stagnation. At Bijapur, *rabi* sorghum yields increased from 15% in BBF to 17.8% (Broad Furrow and ridges), 27.7% (BBF) to 50% in ridges and furrow over farmers practice of cultivation (Average of two years) under different *in-situ* moisture conservation practices.

### Zingg terracing

Zingg terracing is adopted in low to medium-rainfall areas in *Vertisols* with contour/ graded bunds. In Zingg terrace 30% of the area on the upstream side of the bund is leveled and in this leveled area assured crop yields are realized during drought years. This is done by cutting 15

cm of soil and putting it all near the bund to make flat land for 30% of the area on the upstream side of the bunds. A lower one-third portion of the inter-bunded area is leveled to spread the runoff water in a large (receiving) area with cultivation of water-intensive crops while dry crops are cultivated in the unleveled (donor) area. In the leveled one-third portions, the normal crops can be harvested even during severe drought years and it is possible to cultivate two crops during a normal year. This will increase cropping intensity and crop yields. In Vertisols of Bijapur, Zingg terrace increased *rabi* sorghum, sunflower, greengram and pearl millet yields by 39, 82, 113 and 139%, respectively over a period of 5 years (Table 6). The yield advantage was more visible during sub-normal years (Shiratti, et al., 2022).

**Table 6: Effect of Zingg terrace on crop yields ( $\text{kg ha}^{-1}$ ) in Vertisols of Bijapur**

| Crop                          | Average yield ( $\text{kg/ha}$ ) |                   | Yield Advantage (%) | B:C ratio |
|-------------------------------|----------------------------------|-------------------|---------------------|-----------|
|                               | Zingg terrace                    | Farmers' practice |                     |           |
| <i>Rabi</i> sorghum (5 years) | 1075                             | 773               | 39                  | 1.13      |
| Sunflower (5 years)           | 1220                             | 670               | 82                  | 1.45      |
| Greengram (3 years)           | 320                              | 150               | 113                 | 1.04      |
| Pearl millet (3 years)        | 550                              | 230               | 139                 | 1.25      |

### Mulching

Mulching is the covering the cultivated field with unused organic material, sand, pebbles and soil to prevent soil erosion and evaporation losses, facilitate infiltration, improve the water holding capacity of the soil, conserving rainwater *in-situ*. Further through organic mulching/residue incorporation the biomass in the soil feeds the microbes, increases microbial population which help the plants to draw nitrogen and carbon from air and phosphorous and potash from soil besides improving soil micronutrient status. Application of organic surface mulch with vertical mulching at 4 m interval at sowing in Vertisols of Ballari, India, produced 31, 63 and 103% greater sorghum yields in (Rama Mohan Rao et al., 1985). In Vertisols at Sholapur, crop residue incorporation increased sorghum yield from 50 to 70%.

### Dust mulch

Due to the scarcity of organic materials, low-cost method of frequent intercultivation between crop rows creates dust/soil mulch during crop growth. Studies at Ballari have indicated 8% more grain yield over organic mulch and 96% higher yield over control in winter sorghum with intercultivation up to 10 cm soil depth. Both organic and soil mulches produced 63% higher sorghum grain yields over control during below normal/scarcely rainfall situations in black soil region during winter season for the crops cultivated on residual soil water.

### Sand mulching

Sand mulching (2 to 10 cm) conserves top fertile soil and rainwater *in-situ*, reduces wind, water erosion and evaporation in turn increases the water availability in the profile at different stages of crop growth (Hagman, 1984). Sand mulching has been practiced by the farmers in pockets of northern Karnataka and Andhra Pradesh. Experiments conducted with sand mulching at Bijapur and Dharwad indicated 60 to 70% increase sorghum, chickpea, and cotton yields (Anon., 2000 and Sudha, 1999). In Koppal, Gadag and Bagalkot districts of Karnataka with around 600 mm sand mulching increased the cropping intensity to 200% during drought years with cultivation of short duration greengram crop during *kharif*.

### Soil Management

#### Crop residue management

Fertilizer application can be reduced by returning approximately 1.5 Pg (world) of carbon (C) stored in the crop residues produced into the soil which adds OM. A total of nearly 600 Mt of crop residues are generated every year in India from different crops. At Bangalore, incorporation of maize residue at 4 t ha<sup>-1</sup> continuously for three years increased soil moisture content at sowing by 26 and 5% in 0–15 and 15–30 cm depths and in ragi yield increased by 76% compared to the plots without residue. Paddy husk application at 5 t ha<sup>-1</sup> increased soil moisture, infiltration rate and grain yields of sorghum (1<sup>st</sup> year), castor (2<sup>nd</sup> year) sorghum (3<sup>rd</sup> year) by 33, 23 and 14%, respectively. In Vertisols of Ballari, *Dolichos* incorporation at harvest (grain purpose)/45 DAS (mulch purpose) in the Sorghum + *Dolichos* system reduced runoff, soil loss and increased the soil water in the profile. Soil properties i.e. mean weight diameter, organic carbon and nutrient availability (N, P and K) were higher with *Dolichos* incorporation when cultivated with sorghum as compared to sorghum cultivation alone (Table 7). Sorghum grain equivalent was significantly higher (3248) when sorghum cultivated with *Dolichos* for grain purpose compared to the rest of the treatments. Four years experiment results indicated that cultivation of *Dolichos* with sorghum for seed purpose and incorporation of *Dolichos* residual harvest sustained productivity with greater net returns (Nalatwadmath et al. 2006).

**Table 7: Runoff, soil loss, soil properties and sorghum and *Dolichos* yields as influenced by crop residue incorporation**

| Treatments  | Av. of 4 years<br>Runoff (mm) | Soil loss<br>(kg ha <sup>-1</sup> ) | MWD<br>(Microns) | OC<br>(g kg <sup>-1</sup> ) | Available nutrients 0-15 cm (kg ha <sup>-1</sup> )    |     |      | Grain yield (kg ha <sup>-1</sup> ) | Straw yield (kg ha <sup>-1</sup> ) | Sorghum yield (t grain equivalent) |
|---|-------------------------------|-------------------------------------|------------------|-----------------------------|---|-----|------|------------------------------------|------------------------------------|------------------------------------|
|   |                               |                                     |                  |                             | N   | P   | K    |                                    |                                    |                                    |
|   |                               |                                     |                  |                             | T <sub>1</sub> -Sorghum without disturbance (Control) | 142 | 4940 |                                    |                                    |                                    |
| T <sub>2</sub> -Sorghum + Dolichos (Dolichos cultivated for grain and residue incorporation at harvest) | 127                           | 3934                                | 688              | 3.9                         | 199   | 16  | 448  | 167+495                            | 3.01                               | 4248                               |
| T <sub>3</sub> -Sorghum + Dolichos (Dolichos cultivation and residue used as mulch at 45 DAS)           | 129                           | 4339                                | 685              | 3.8                         | 198   | 15  | 442  | 2121                               | 3.27                               | 2535                               |
| T <sub>4</sub> -Sorghum + Dolichos (Dolichos incorporated into the soil at 45 DAS)                      | 122                           | 3751                                | 696              | 4.0                         | 202   | 16  | 483  | 2301                               | 3.61                               | 2756                               |
| T <sub>5</sub> -Sorghum with intercultivation (Twice soil disturbance)                                  | 132                           | 4491                                | 589              | 3.6                         | 183   | 13  | 499  | 1916                               | 3.05                               | 2303                               |
| LSD (P=0.05)  | --                            | --                                  | 35               | 0.03                        | 26  | NS  | NS   | --                                 | --                                 | 397                                |

Source: Nalatwadmathet *al.* (2006); DAS=Days after sowing

### Application of soil amendments for enhancing soil resilience

#### Gypsum application

Soil amendment like Gypsum is added to the soil to improve its physical properties, such as water retention, permeability, water infiltration, drainage, aeration, structure and to provide a better environment for plant roots and crop growth. Studies indicated through gypsum application reduces Exchangeable Sodium Percentage >7.0 to < 7 (Anon., 1981).

#### Tank silt application

Desiltation of tank silt rejuvenates the tanks, improves the tank water holding capacity and recharges the groundwater. Application of tank silt to croplands improves soil properties, reduces the fertilizer application, and meets the water and nutrients of the rainfed crops in a cost-effective manner. Tank silt improves crop yields and brings dynamic changes in the land use pattern in the region (CRIDA, 2006; Dhan, 2004 and Osman et al. 2001 and 2007). Tank silt application to cotton increased the benefit-cost ratio (BCR) from 1.43 to 1.86 and in chillies the BCR was higher by 11% (2.54) over control (2.28). Application of available tank silt or heavy textured soil in the top 50 cm depth decreased bulk density and increased soil water content from 6.5 to 23.5%. The improved soil water and nutrient status with application of tank silt/clay increased the tomato and lady's finger yields by 10.8 and 10.5%, respectively in the Ranga Reddy District of Andhra Pradesh (Singa Rao, 2004).

## Runoff Harvesting and Recycling

In the SAT of south India, nearly 10% to 40% of rainfall goes as runoff from the farmers' fields depending upon the land slope. Of this runoff, nearly 10% can be harvested and recycled as protective irrigation especially during subnormal rainfall/drought years through farm ponds.

### Farm Ponds

Dug out farm ponds size varies with rainfall ranging from 200 to 3000<sup>3</sup>. Considering an annual rainfall of <1000 mm, a farm pond of 250 m<sup>3</sup> capacity with 6 m × 6 m bottom width, 12 m × 12 m top width, 3 m depth and lined either with soil: cement (8:1) is ideal per hectare catchment area. The stored water in the farm pond is used for protective irrigation, fish rearing, Azolla cultivation, nourishing horticultural plants, spraying plant protection chemicals, drinking water to livestock etc. Recycling farm pond water in the SAT region of south India reduces moisture stress especially in winter sorghum at boot leaf stage or appearance of crack and in chickpea at pod development stage stabilizes crop yields especially during drought years.

### Supplemental irrigation

Runoff collected in the farm pond is applied to the crops by adopting any of these methods (check basin, border strips, furrow, sub-surface, sprinkler and drip) as convenient to the farmer and the facilities available with him based on his socio-economic conditions.

### Border strips

In India, the surface method of irrigation covers more than 95% of irrigated area. The excess runoff conserved in farm pond when used as supplemental irrigation at critical stages of crop growth increased the yields of beedi tobacco by 17% at Varanasi, 198% in wheat at Chandigarh. Similarly, in medium deep black soils of Bijapur, the average responses over a period of 4-5 years indicated yield increase varying from 33 to 92% with one life saving irrigation. The increase in winter sorghum yields during drought year was 157% with application of 11.8 cm irrigation at boot leaf stage whereas during severe drought year yield increased by 219% with 6.5 cm irrigation at knee height stage (Radder et al., 1995). The response to irrigation was only 12% (2190 to 2450 kg ha<sup>-1</sup>) with 5 cm irrigation at grain filling stage during normal rainfall situation. The runoff when received in the months of May and June is utilized for a short duration greengram by providing supplemental irrigation from harvested water (Adhikari et al., 2000). The supplemental irrigation during water stress



brought about 49% to 86% increases in yields in groundnut and sorghum in Chinnatekur watershed, whereas, in winter sorghum yield increased by 34% at Joladarasi watershed in black soils (Rama Mohan Rao et al., 2000a) (Table 8).

**Table 8: Impact of drought management techniques on grain yields of crops (kg ha<sup>-1</sup>)**

| Technique               | Crops     | Chinnatekur |      |            | Joladarasi |      |            |
|-------------------------|-----------|-------------|------|------------|------------|------|------------|
|                         |           | Without     | With | % increase | Without    | With | % increase |
| Supplemental irrigation |           |             |      |            |            |      |            |
|                         | Sorghum   | 570         | 1060 | 86         | 1460       | 1950 | 34         |
|                         | Groundnut | 610         | 910  | 49         | —          | —    | —          |

### Sprinkler and drip irrigations

At Bijapur drip irrigation using pond water saved more than 50% of water compared to modified sprinkler and surface methods of application (Table 9). Even at Solapur, sprinkler irrigation increased grain yield of *rabi* sorghum compared to contour furrow irrigation.

**Table 9: Response of fruit crops to different irrigation systems in Vertisols at Bijapur**

| Method of irrigation            | Yield increase over control (%) |     |             |
|---------------------------------|---------------------------------|-----|-------------|
|                                 | Ber                             | Fig | Pomegranate |
| Drip                            | 252                             | 228 | 133         |
| Modified sprinkler (Jet method) | 189                             | 128 | 52          |
| Surface irrigation              | 149                             | 82  | 60          |

### Recommended Moisture Conservation Measures

The research results at both the Research Stations and in the farmer's, fields indicate that the rainwater conservation practices reduced runoff, soil and nutrient losses and recharged the soil profile both during rainy and post-rainy season and increased the yields of different crops especially during drought years. An comparison of the effects of land management systems on reduction of runoff and increase in yield in Alfisols of Hyderabad is furnished in Table 10. The suitable *in-situ* moisture conservation practices for different crops under different soil types at dryland Centre's in India are mentioned in table 11. Recommended soil and moisture conservation measures for different rainfall zones in India are summarized in table 12.

**Table 10: Effect of land management on runoff and crop yields in Alfisols and CRIDA**

| Land management                                   | Runoff reduction | Crops   | Yield increase (%) |
|---|------------------|---------|--------------------|
| Deep tillage                                      | 46               | Sorghum | 31                 |
|   | 34*              | Sorghum | 28                 |
| Scoops (40 mm)                                    | 69               | Sorghum | 28                 |
| Tied ridges                                       | 39               | Sorghum | 35                 |
| FYM at 15 t ha <sup>-1</sup>                      | 51               | Maize   | 56                 |
| Straw mulch <sup>a</sup> (15 t ha <sup>-1</sup> ) | 76               | Maize   | 53                 |
| Contour bunds <sup>b</sup>                        | 37               | Maize   | 36                 |
| Graded bunds <sup>b</sup>                         | 31               | Maize   | NA                 |
| Porous barrier <sup>c</sup>                       | 66               | Maize   | NA                 |
| Sand mulchd (95%)                                 | 80               | -       | -                  |

Source: Rao et al. (1994).

a = Effect after 4 years of continuous application; b = average of 4 years; c = porous barriers are 3 years old; d = average of 2 years after bringing the sand content of the surface to 95%.

\*Data from CRIDA; other data from ICRISAT. Tillage results are presented as % increase over traditional practice. Data on FYM and straw are presented as % increase over an unamended control.

**Table 11: Recommended/demonstrated *in-situ* rainwater conservation measures in the farmers' fields at different Dryland Centres/locations**

| Location   | Crop           | Suitable inter-terrace land treatments           |
|------------|----------------|--|
| Bijapur    | Safflower      | Compartmental bunding                            |
|            | Chickpea       | Compartmental bunding; Ridges and furrows        |
|            | Winter sorghum | Tied ridging                                     |
| Akola      | Pigeonpea      | Opening furrow at 30 DAS after every two rows    |
| Bellary    | Winter sorghum | Compartmental bunding; Ridges and furrows        |
|            | Chickpea       | Compartmental bunding                            |
|            | Safflower      | Bedding system                                   |
| Kovilpatti | Winter sorghum | Compartmental bunding                            |
| Sholapur   | Chickpea       | Compartmental bunding                            |
| Bangalore  | Pigeonpea      | Ridges and furrows; Furrow at 3 m interval       |
| Anantapur  | Groundnut      | Contour cultivation; Dead furrow at 3 m interval |

**Table 12: Recommended soil and moisture conservation measures for different rainfall zones in India**

| Seasonal Rainfall (mm)            |  |                      |                     |
|-----------------------------------|--|----------------------|---------------------|
| <500                              | 500-750                                  | 750-1000             | >1000               |
| Contour cultivation               | Contour cultivation                      | BBF (Vertisols)      | BBF (Vertisols)     |
| Conservation/dead furrows         | Conservation furrows                     | Conservation furrows | Field bunds         |
| Ridges and furrows                | Ridging                                  | Sowing across slope  | Vegetative barriers |
| Sowing across slope               | Sowing across slope                      | Tillage              | Graded bunds        |
| Mulching                          | Vegetative barriers                      | Vegetative barriers  | Vegetative bunds    |
| Scoops                            | Scoops                                   | Small basins         | Chos                |
| Compartmental bunding             | Tied ridges                              | Vegetative bunds     | Level terrace       |
| Graded border strips              | Mulching                                 | Field bunds          |                     |
| Tied ridges                       | Zingg terrace                            | Graded bunds         |                     |
| Off-season tillage                | Off-season tillage                       | Nadi                 |                     |
| Inter-row water harvesting system | BBF                                      | Zingg terrace        |                     |
| <b>Small basins</b>               | <b>Inter-row water harvesting system</b> |                      |                     |
| Contour bunds                     | Small basins                             |                      |                     |
| Field bunds                       | Modified contour bunds                   |                      |                     |
| Khadin                            | Field bunds                              |                      |                     |
| Graded bunds                      | Graded bunds                             |                      |                     |

Source: Vittal *et al.* (2003); Somasundaram *et al.* (2014); Patil (2013); Patil *et al.* (2013)

### Applications of Nanotechnology, Hydrophobic and Polymers in Rainwater Conservation

In the recent past, nanotechnology has garnered significant scientific gusto because of its extensive utility even in agricultural sector. Emerging nano fertilizers and insecticides represent promising technologies for enhancing plant growth and protection. Nano fertilizers (NFs) can substitute 25% chemical fertilizers and reduce the negative consequences of fertilizers.

### **Nanotechnology for increasing soil water retention**

Wong and Karn (2012) reported that different companies are starting to produce new nanomaterials to mitigate global problems such as the scarcity of water for irrigation. A nano-sand water repellent was developed to prevent water drainage in drylands and support the release of nutrients and molecules to support plant growth (Davidson and Gu, 2012). The treated sand can stop water drainage below the depth of the plant roots and maintains a subsurface water table, providing vegetation with a constant water supply. Nano materials are nanomembranes for water purification and desalination that would be several times more energy efficient. Nano clay is made up of clay minerals divided into their smallest components that are 0.7-1.5 nm thick, with a diameter of 20-300 nm and mixes with water. Nano clay works as a binder and keeps moisture in the sand and thus it creates constant growth conditions for plants to survive under dry conditions (Mura et al., 2013). Padidaret *al.* (2015), found that the application of nano clay at a concentration of 2000 ppm reduced soil erosion due to wind.

### **Application of zeolites and synthesized nanomaterials for efficient soil water use**

Zeolites are naturally occurring aluminosilicates that exhibit alkaline hydration and contain a wide range of practical applications, such as their utilization as soil-binding agents and nutritional supplements. The mineral zeolites include analcime, chabazite, clinoptilolite, heulandite, natrolite, phillipsite. Zeolites absorb and slowly release water and used as a soil amendment to improve water retention in sandy and low-clay soils and to improve porosity of impermeable soils. They are used to conserve water in the root zone in conjunction with traditional techniques, such as mulch farming and application of manure (Bhattacharyya et al., 2006; Pal et al., 2006; Oren and Kaya, 2006). The zeolites pretreated with nutrients are used as an agent for the slow release of nitrogen and phosphorus and enhance the availability of micronutrients, such as zinc (Oren and Kaya, 2006). The zeolites are used in soil remediation to absorb metal cations and reduce local concentrations of toxic substances that inhibit plant growth and nitrogen-fixing soil microbes (Pisarovic et al., 2003). Advances in nanotechnology suggest that it is possible to engineer zeolites further to increase the efficiency of fertilizer by developing slow-release delivery molecules that decrease losses to water and air and increase uptake by plants (NRC, 2008). The dry-Vertisols when rapidly exposed to water, they release a large amount of heat at the soil surface, which causes slaking of soil aggregates that reduces the ability of water to percolate downward and results in water runoff. Although no current method addresses this problem, it is conceivable that materials

could be developed to interrupt the process by improving the biophysical stability of soil aggregates and dissipating the heat emitted during wetting. According to Inglezakis et al. (2012), it has been determined that the zeolites application leads to improvements in infiltration rate, saturated hydraulic conductivity, cation exchange capacity, and the reduction of water losses caused by deep percolation.

### Summary

*In-situ* and *ex-situ* rainwater conservation practices have great potential to conserve rainwater and supplement moisture to the crops especially during droughts. Thus, based on definite climatic events and rainfall regime, rainwater management interventions are needs to be prioritized. Certainty of climate change and predicted increase in high intensity rainfall events with reduced number of rainy days demands for large scale adoption *in-situ* rainwater conservation measures at Farm levels. Simultaneously it also calls for continuous efforts from all stakeholders from policy makers to the farmers to work together to design programs/schemes with proper credit allocation and execution through participatory approach. Regional specific, prioritized rainwater harvesting techniques needs to be popularized and adopted at farm level by converging government programs to cope with extreme climatic events for sustainable crop productivity and ensure water for all farm enterprises. The Government schemes like MNREGA may be further strengthened to build awareness and to construct rainwater conservation structures in rural areas to cope with acute drought situation especially in arid and semiarid regions of India. To enhance conserved rainwater use efficiency adoption of improved irrigation techniques such as alternate furrow, sprinkler, drip irrigations is essential in tandem with crop diversification towards low water consuming crops and cultivars. Research in nanotechnology particularly of (i) engineered nano-products (NPs) for soils moisture retention and release, (ii) development of nano-magnets for soil contaminant retrieval, (iii) development of nano-membranes for water treatment/purification, (iv) fertilization and herbicide application through NPs, (v) synthesis of nano fertilizers for soil and plant application, and (vi) development of nano-sensors to monitor soil quality are essential to enhance potential of climate reliance in agriculture.

## References

- Adams A. and Jumpah, E.T. 2021. Agricultural technologies adoption and smallholder farmers' welfare: Evidence from Northern Ghana. *Cogent Economics & Finance* (2021), **9**:2006905 <https://doi.org/10.1080/23322039.2021.2006905>.
- Adhikari, R.N., Rama Mohan Rao, M.S., Husenappa, V., James, E.V. and Reddu, K.K. 2000. Rain water management for erosion control and yield stability in rainfed Vertisols of the semi-arid region of Deccan Plateau. In: *Advances in Land Resource Management for 21<sup>st</sup> Century*, Soil Conservation Society of India, New Delhi, 377-388.
- Anonymous. 2000. Annual Progress Report, 1999–2000. AICRPDLA. Bijapur, Karnataka, India, Annual Report 1999–2000 Central Research Institute for Dryland Agriculture, Hyderabad, India, pp. 46–47.
- Ayenew, W., Laken, T. and Kristos, E. H. (2020). Agricultural technology adoption and its impact on smallholder farmers' welfare in Ethiopia. *African Journal of Agricultural Research*, **15**(3):431–445. <https://doi.org/10.5897/AJAR2019.14302>
- Barnaby, W. 2009. Do Nations goto war over water? *Nature*, **458**: 282-283.
- Bhattacharyya, T., Pal, D.K., Lal, S., Chandran, P. and Ray, S.K. 2006. Formation and persistence of Mollisols on Zeolitic Deccan basalt of humid tropical India. *Geoderma*, **136**:609-620.
- Channappa, T.C. 1994. *In-situ* moisture conservation in Arid and Semi-Arid Tropics. *Indian Journal of Soil Conservation*, **22**(1&2):26–41.
- Davidson, D., Gu, F.X. 2012. Materials for sustained and controlled release of nutrients and molecules to support plant growth. *Journal of Agricultural Food Chemistry*, **60**: 870–876.
- Dhan. 2004. Vision for village tanks of Tamil Nadu, Development of Human Action (DHAN) Foundation, Madurai, Tamil Nadu, p. 34.
- FAOSTAT. 2019. Food and Agricultural Organization of the United Nations (FAO). FAO Statistical Database. 2019. Available online: <http://faostat.fao.org> (accessed on 20 July 2023).
- Inglezakis, V.J., Moreno, J.L. and Doula, M. 2012. Olive oil waste management EU legislation: current situation and policy recommendations. *International Journal of Chemical and Environmental Engineering Systems*. **3**(2):65–77.
- Habib-ur-Rahman M., Ahmad, A., Raza, A., Hasnain, M.U., Alharby, H.F., Alzahrani, Y.M., Bamagoos, A.A., Hakeem, K.R., Ahmad, S., Nasim, W., Ali, S., Mansour, F. and E.L. Sabagh. 2022. Impact of climate change on agricultural production; Issues, challenges, and opportunities in Asia. *Front. Plant Sci.* **13**:925548. doi: 10.3389/fpls.2022.925548.
- Hagman, G. 1984. Prevention better than cure: Report on Human and Natural Disasters in the Third World, Stockholm: Swedish Red Cross.

- Inglezakis, V., Elaiopoulos, K., Aggelatou, V., Zorpas, A.A. 2012. Treatment of underground water in open flow and closed—loop fixed bed systems by utilizing the natural minerals clinoptilolite and vermiculite. *Desalination Water Treat.* 39: 215–227.
- Justice, A.T. and Tobias, W. 2016. Beyond adoption: welfare effects of farmer innovation behaviour in Ghana. ZEF Discussion Paper on Development Policy, No. 216, University of Bonn, Centre for Development Research (ZEF), Bonn.
- Kopalo, A., Kopalo, A. J. and Yildiz, F. 2021. Welfare and productivity impact of the adoption of biofortified cassava by smallholder farmers in Nigeria. *Cogent Food and Agriculture*, 7(1): 1886662. <https://doi.org/10.80/23311932.2021.1886662>.
- Krishnappa, A.M., Arun Kumar, Y.S., Munikappa. and Hegde, B.R. 1999. Improved *in-situ* moisture conservation practices for stabilized crop yields in Drylands. In Fifty Years of Dryland Agriculture Research in India. (Ed. H.P. Singh *et al.*). pp. 291–300.
- Krishnappa, A.M., Arun Kumar, Y.S., Gopal Reddy, T. and Nagarajan, T. 1994. Watershed Approach – A boon for dryland agriculture. The experience of Operational Research Project in Kabbalanala, University of Agriculture Sciences, Bangalore, India.
- Kuotsu, K., Anup Das, Lal, R., Munda, G.C., Ghosh, P.K. and Ngachan, S.V. 2014. Land forming and tillage effects on soil properties and productivity of rainfed groundnut (*Arachis hypogaea* L.)–rapeseed (*Brassica campestris* L.) cropping system in northeastern India. *Soil and Tillage Research*, 142:15–24.
- Mura, S., Seddaiu, G., Bacchini, F., Roggero, P.P. and Greppi, G.F. 2013. Advances of nanotechnology in agro-environmental studies. *Italian Journal of Agronomy*, 8:18.
- Nalatwadmath, S.K., Patil, S.L., Adhikari, R.N. and Mana Mohan, S. 2006. Effect of crop residue management on soil erosion, moisture conservation, soil properties and sorghum yield on Vertisols under Dryland conditions of Semi-Arid Tropics in India. *Indian Journal of Dryland Agricultural Research & Development*, 21(2):99–104.
- NRC. 2008. Emerging Technologies to Benefit Farmers in Sub-Saharan Africa and South Asia. National Academies Press, Washington DC. USA. p. 292. (<http://www.nap.edu/catalog/12455.html>).
- Oren, A.H. and Kaya, A. 2006. Factors affecting absorption characteristics of  $Zn^{2+}$  on two natural zeolites. *Journal of Hazardous Material*, 131:59–65.
- Osman, M., Mishra, P.K., Mishra, A.K., Dixit, S., Kausalya, R., Singh, H.P., Rama Rao, C.A. and Korwar, G.R. 2001. Common Pool Resources in Semi-arid India: A review of dynamic, management and livelihood contributions, Study funded by DFID (UK), NRI Report No. 2649, p. 102.
- Osman, M., Ramakrishna, Y.S. and Haffis, S. 2007. Rejuvenating Tanks for Self-Sustainable Rainfed Agriculture in India. *Agricultural Situation in India*, LXIV(5):67–70.
- Padidar, M., Jalalian, A., Abdouss, M., Najaf, P., Honarjoo, N. and Fallahzade, J. 2015. Effects of Nano-clay on Some Physical Properties of Sandy Soil and Wind Erosion. *Int J. Soil Sci.* 11(1):9–13

- Pal, D.K., Bhattacharyya, T., Ray, S.K., Chandran, P., Srivastava, P., Durge, S.L. and Bhuse, S.R. 2006. Significance of soil modifiers (Ca-zeolites and gypsum) in naturally degraded Vertisols of the peninsular India in redefining the sodic soils. *Geoderma*, 136:210-228.
- Pathak, P. and Laryea, K.B. 1995. Soil and water conservation in the Indian SAT: Principles and improved practices. In Sustainable Development of Dryland Agriculture in India, (Editor, R.P. Singh), Scientific Publishers, Jodhpur. India. pp. 83–94.
- Patil, S.L. 1998. Response of *rabi* sorghum (*Sorghum bicolor* (L.) Moench) to tillage, moisture conservation practices, organics and nitrogen in Vertisols of Semi-Arid Tropics. Ph.D. Thesis submitted to University of Agricultural Sciences, Dharwad, Karnataka, India.
- Patil, S.L. 2003. Effect of moisture conservation practices and nitrogen application on growth and yield of winter sorghum in Vertisols of Semi–Arid Tropics of South India. Special International Symposium on Transactions in Agriculture for Enhancing Water Productivity, 23–25 September, 2003, TNAU, Tamil Nadu, India, pp.70–71.
- Patil, S.L. 2007. Reduced tillage practices and integrated nutrient management of sorghum grown in Vertisols of SAT-India. In: Abstract proceedings of South Asian Conference on “Water in Agriculture: Management Options for Increasing Crop Productivity per Drop of Water” held at Indira Gandhi Krishi Vishwavidyalaya, Raipur (CG) during November 15-17, 2007, p. 78.
- Patil, S.L. 2013. Winter sorghum (*Sorghum bicolor*) productivity as influenced by tillage practices and nitrogen management in Vertisols of SAT, India. *Soil & Tillage Research*, 126: 183–192.
- Patil, S.L. and Sheelavantar, M.N. 2004. Effect of cultural practices on soil properties, moisture conservation and grain yield of winter sorghum (*Sorghum bicolor* L. Moench) in Semi–Arid Tropics of India. *Agricultural Water Management*, 64 (1): 49–67.
- Patil, S.L. and Sheelavantar, M.N. 2006. Soil water conservation and yield of winter sorghum (*Sorghum bicolor* L. Moench) as influenced by tillage, organic materials and nitrogen fertilizer in Semi-Arid tropical India. *Soil & Tillage Research*, 89: 246–257.
- Patil, S.L., Math, S.K.N., Mishra, P.K. and Manikatti, S.M. 2013. Effect of rainwater conservation practices and integrated nutrient management on resource conservation and sunflower productivity in SAT Vertisols. National Conference on Sustainable Water Resources Planning Management and Impact Climate Change Organized by Centre of Excellence in Water Resource Management Department of Civil Engineering, Birla Institute of Technology and Science, Pilani, Hyderabad, India from 5-6<sup>th</sup> April, pp. 70–72.
- Peng, Z., Wang, L., Xie, J., Li L., Coulter, J.A., Zhang, R., Luo, Z., Kholova, J., Choudhary, S. 2019. Conservation Tillage Increases Water Use Efficiency of Spring Wheat by

- Optimizing Water Transfer in a Semi-Arid Environment. *Agronomy*, 2019; **9**(10):583. <https://doi.org/10.3390/agronomy9100583>
- Pisarovic, A., Filipan, T. and Tisma, S. 2003. Application of zeolite based special substrates in agriculture-Ecological and economical justification. *Period. Biology*, 105:287-293.
- Radder, G.D., Itnal, C.J. and Belgami, M.L. 1995. Protective irrigation (life saving): Principles and practices. In *Sustainable Development of Dryland Agriculture in India*. Eds. Singh, Scientific Publishers, Jodhpur, India, pp. 207–215.
- Rama Mohan Rao, M.S., Adhikari, R.N., Math, S.K.N., Padmaiah, M.P., Chandrappa, M. and Reddy, K.K. 2000a. Resource conservation through watershed management for economic and financial sustainability of dryland agriculture in the semi-arid regions of Deccan Plateau. In: *Advances in Land Resource Management for 21<sup>st</sup> Century*, Proc. Int. Conf. on Land Resource Management for Food, *Employment and Environmental Security*, 9-13 November 2000, New Delhi, 285–301.
- Rama Mohan Rao, M.S., Patil, S.L., Math, S.K.N., Shrimali, S.S. and Srivastva, A.K. 2000b. Effect of different agronomic and mechanical measures in reducing soil and water losses in the Vertisols of Semi-Arid Tropics of South India. International Conference on “Managing natural resources for sustainable agricultural production in the 21st century”. Extended summary, vol.3: voluntary papers. *Resource Management*. 14–18 February 2000, New Delhi, India, 1227–1228.
- Rama Mohan Rao, M.S., Ranga Rao, V., Ramachandram, M. and Agnihotri, R.C. 1978. Effect of Vertical mulch on moisture conservation and yield of sorghum in Vertisols. *Agricultural Water Management*, **1**:333–342.
- Ranga Rao, V., Ramachandram, M. and Rama Mohan Rao, M.S. 1978. Some simple crop production practices for efficient exploitation of seasonal aberrations in rainfall in rainfed rabi belt of Bellary. II. Mid seasonal corrections in plant population as a life saving practice. *Mysore Journal of Agricultural Sciences*, **12**:425–433.
- Rao, K.P.C., Cogle A.L., Srinivasan, S.T., Yule D.F. and Smith, G.D. 1994. Effect of Soil Management Practices on Runoff and Infiltration Processes of Hardsetting Alfisol in Semi-Arid Tropics. *8<sup>th</sup> ISCO Conference, New Delhi, India*, pp. 1287–1294.
- Sanghi, N.K. and Korwar, G.R. 1987. Integrated pest management. In: *Technological Advances in Dryland Agriculture*, (Ed.) S.P. Singh *et al.*, Central Research Institute for Dryland Agriculture, Hyderabad, India, pp. 101–119.
- Shirahatti M.S., Surakod V.S., Nandagavi R.A., Momin, U.M., Kumara B.H, Patil S.B., Ravindra Chary G., Gaddankeri, M.A., Savita G. Kanthi and Patil H.S. 2022. Five Decades of Dryland Agriculture Research for Vertisols of Northern Karnataka. Regional Agricultural Research Station, Vijayapura.
- Somasundram J., Lakaria, B.L., Saha, R., Sinha, N.K., Jha, P., Chaudhary, R.S., Singh, R.K., Mandal, D., Hati, K.M., Ramesh, K., Vassanda Coumar, M., Biswas, A.K., Dey, P., Sammi Reddy K. and Subba Rao. A. 2014. Management of stressed soils of dryland



- agriculture in semi-arid tropics– A Review. *Indian Journal of Soil Conservation*, 42(2):178–187.
- Sudha, K.N. 1999. Resource of rainfed groundnut (*Arachis hypogaea* L.) to sand mulching and organics in VerticInceptisols. *M.Sc. (Agri.) Thesis* submitted to University of Agricultural Sciences Dharwad, Karnataka, India.
- Teka, A. and Lee, S. 2020. Do agricultural package programs improve the welfare of rural people? Evidence from smallholder farmers in Ethiopia. *Agriculture*, **10**(190):1–20. <https://doi.org/10.3390/agriculture10050190>.
- Tesfuhuney, W., Ravuluma, M., Dzvene, A.R., Bello, Z., Andries, F., Walker, S., Cammarano, D. 2023. In-Field Rainwater Harvesting Tillage in Semi-Arid Ecosystems: I Maize–Bean Intercrop Performance and Productivity. *Plants*, **12**, 3027. <https://doi.org/10.3390/plants12173027>
- Momin,U.M., Ramesh Beerge, Basavaraj Jamakhandi and Maheshwar S. Shirahatti, 2021.Effect of compartment bunding system to enhance the productivity and profitability using partial mechanization for chickpea under Semi-Arid region of Northern Karnataka. *Int. J. Curr. Microbial. App. Sci.***10**(02):2329-2346doi: <https://doi.org/10.20546/ijcmas.2021.1002.277>.
- Wossen, T., Abdoulaye, T., Alene, A., Heile, M. G., Feleke, S., Olanrewaju, A. andManyong, V. 2017. Impacts of extension access and co-operative membership on technology adoption and house-hold welfare. *Journal of Rural Studies*, **54**: 223–233. <https://doi.org/10.1016/j.jrurstud.2017.06.022>.
- Wong, S. and Karn, B. 2012. Ensuring sustainability with green nanotechnology. *Nanotechnology*, **27**: 23–29.
- Yao, J., Liu, H., Huang, J. *et al.*2020. Accelerated dryland expansion regulates future variability in dryland gross primary production. *Nat.Commun.*,**11**:1665 (2020). <https://doi.org/10.1038/s41467-020-15515-2>

## Participatory Watershed Management: Cases from TSP and SCSP programs

*A K Singh<sup>1</sup> and Gaurav Singh<sup>2</sup>*

*Pr. Sci. (SWCE)<sup>1</sup> & Sr. Sci. (SWCE)<sup>2</sup>, ICAR-Indian Institute of Soil & Water Conservation, Research Centre, Vasad-388306, Anand, Gujarat*

### Introduction

Small land holders Scheduled Castes and Schedule Tribe (SC/ST) farmers are one of the worst suffering groups, who are at the bottom of the social ladder in India. With SC/ST families having the lowest land ownership in India, these constraints often make them more dependent on wage labour. It is reported that about 71 per cent of SC /ST farm wage worker reported a loss of an average of 43 work days due to discrimination in hiring. Hence, to improve the livelihood of these smallholders on a sustainable basis and enabling them to participate in the development process in an equitable manner, the Ministry of Social Justice and empowerment and Ministry of Tribal affairs has implemented Schedules Caste Sub-Plan (SCSP) and Tribal Sub-Plan to ensure flow of both targeted financial and physical benefits to Scheduled Castes and Schedule Tribe caste. The plans were manifested under different heads viz. Tribal Sub -Plan (TSP) and Schedule Castes Sub- Plan (SCSP). The detail of activities under taken at the Institute Head Quarters Dehradun and Research Centres are listed as under.

### Achievements under Schedule Castes Sub-Plan (SCSP) Programs

The TSP/STC & SCSP program was aimed for the integrated development of Schedule Tribe and Scheduled Caste dominated areas with priority for providing basic minimum services like creating productive assets and human resource development by providing adequate education and health services, professional training, irrigation and drinking water, nutrition, forest produces (fuel, fodder, fibre), agriculture implements, agriculture produces, rural housing, livelihood security and income generating activities, etc. The program has come handy to upscale the doable farm technologies of IISWC and others in the farmer's field. Considering the prevailing farming situations and problems, many interventions for conservation of natural resources to improve agricultural production have been implemented by IISWC, Dehradun and its 8 Research Centres to benefit Scheduled Caste Communities who largely depend on traditional farming and animal husbandry, etc. and Natural Resource Management. It was started in 21 selected Scheduled Caste villages/hamlets spread over 15 Gram Panchayats, covering 13 block / Taluka, 10 Districts of 9 States in the Country. Total number of families covered under SCSP programme is 2132. Technological demonstrations and

capacity building for holistic improvement of crop production, income generation towards resource conservation, and upliftment of Scheduled Caste farmers were major focus.

### **Implementation Strategies for SCSP and TSP programs**

The Scheduled Caste and Schedule Tribe dominated villages were selected based on SCSP and TSP guidelines and standard extension methods (PRA exercise). The Detailed Project Report (DPR) was prepared after assessing the existing resources of villages through watershed approach and transect walk. The various interventions/activities identified accounted the available resources, prevailing farming situations and problems, natural resources conservation needs so as to improve agricultural production and upliftment of rural and socially deprived communities.

#### **The major activities implemented were:**

1. Doubling farmer income through agriculture and horticultural interventions
2. Development of sustainable agroforestry systems
3. Livelihood support through income generating activities
4. Soil and water conservation measures for production and protection purpose
5. Water harvesting & recycling including ground water recharge
6. Improvement in water & nutrient use efficiency
7. Capacity building and community resource development
8. Livestock improvement

#### **Financial achievements under SCSP program**

Total budget of Rs. 152.13 lakhs (Rs. 117.13 lakhs in operational + Rs. 35 lakhs in capital) was allocated and utilized for implementation of approved activities in selected Scheduled Caste dominated villages adopted during the year 2023-24. The major expenditure of Rs. 57.314 lakhs (37.7%) incurred on demonstration and implementation of Soil and Water Conservation technologies developed by ICAR-IISWC at Dehradun and its regional research centres followed by Rs. 21.534 lakhs (14.20 %) in income generating activities, 19.431 lakhs (12.8 % ) in horticultural and forestry activities, Rs. 15.262 lakhs ( 10.0% ) in agricultural implements, Rs. 12.759 lakhs ( 8.4 %) in crop production, Rs. 11.632 lakhs ( 7.6 %) in demonstrations, Rs. 10.088 lakhs ( 6.6 %) in capacity building and Rs. 4.110 lakhs ( 2.7 %) in other activities (Table 1). About 6301 numbers of resource poor farmers were benefitted with these activities The maximum numbers of beneficiaries (2664) were under capacity building/awareness camp/exhibition followed by 885 (crop production), 624 (horticultural and forestry activities), 576 (demonstrations), 571 (income generation

activities, 556 (soil and water conservation activities), 390 (agriculture implements), and 35 numbers other activities carried out in the SCSP village. The total area covered by various activities was 709.70 ha. The maximum total area covered by Research Centre at Vasad 24.09%, followed by Ooty 13.78 % , Dehradun 12.79 % , Bellari 10.57 % , Datia 10.43 % , Kota 9.16 % , Koraput 7.75 % , Chandigarh 6.35 % and minimum in Agra 5.07 % . However, the maximum number of beneficiaries were from HQ, Dehradun Centre 21.58% followed by Agra 17.79 % , Vasad 14.44%, Ooty 8.57 % , Bellari 8.13 % , Koraput 7.95 % , Chandigarh 7.24 % , Kota 7.16 % and Datia 7.14 % , respectively.

### Physical achievements under SCSP programs

**Table 1:** Activities wise physical and financial achievements under SCSP Programme for the financial year 2023-24

| S. No. | Activities under SCSP Program   | Unit | Qty.      | Area covered (ha) | Budget utilised ( lakhs) | Beneficiaries (Nos.) |
|--------|---|------|-----------|-------------------|--------------------------|----------------------|
| 1.     | Capacity building / Awareness camp / Exhibition / Exposure visits, etc. | No.  | 44        | 0                 | 10.088                   | 2664                 |
| 2.     | Demonstrations  | No.  | 305       | 141.2             | 11.632                   | 576                  |
| 3.     | Agriculture Implements  | No.  | 141       | 10                | 15.262                   | 390                  |
| 4.     | Soil and Water Conservation Activities                                  | No.  | 79        | 247.5             | 57.314                   | 556                  |
| 5.     | Income Generating Activities  | No.  | 27        | 0.0               | 21.534                   | 571                  |
| 6.     | Crop Production   | Kg.  | 8800      | 220.3             | 12.759                   | 885                  |
| 7.     | Horticulture and Forestry Activities                                    | No.  | 1620<br>1 | 85.9              | 19.431                   | 624                  |
| 8.     | Others  | No.  | 407       | 5                 | 4.110                    | 35                   |
|        | <b>Total</b>  |      |           | <b>709.70</b>     | <b>152.130</b>           | <b>6301</b>          |

### Capacity Building Programs under SCSP

KisanGosthi organized on the occasion of World Soil Day under SCSP village Padra, Taluka-Tarapur, Anand, Gujarat. Total 75 farmers got benefitted from the program. The program was attended by officials from Anand Agricultural University and NGO's. The farmers were distributed tarpaulin sheet for sheets for protection of crops in field and other field operations. The farmers were demonstrated about the soil sample collection method for the soil testing. The soil testing and related literature were demonstrated by the officials from GSFC, Vadodara, Gujarat.

### Water Resource Development under SCSP

The open wells were renovated and cleaned in village-NavagamVanta, Taluka-Khambhat, Anand, Gujarat under SCSP program. The open wells are used for drinking and irrigation purpose by the farmers. Total 65 farmers got benefitted from the program. The irrigated area also increased by 15 ha in the village after the renovation and restoration of these open wells in the farmer's field.



De-siltation of water harvesting structure in the village-Gudel, Taluka-Khambhat, District-Anand, Gujarat. The activity has benefitted about 75 farmers family by increasing the availability of good quality water for domestic and irrigation needs. The cleaning and removal of aquatic weeds was also carried out for improving the quality of water used for drinking, domestic and irrigation needs of the SC farmer's family. Installation of lift irrigation system with underground pipeline network in the village-Gudel, Taluka-Khambhat, District-Anand, Gujarat. The 1250 meters of underground pipeline network with outlets given in farmer's field along with 8 HP Diesel pump set for lifting water from canal will save water losses in conveyance system. This activity has benefitted about 75 farmers family by increasing irrigated area by 40 ha and crop yield by 30%. The farmer's income has increased by 20-30% per farmers in the village.



### **Climate Resilient Crop Production System under SCSP**

Demonstration and distribution of Gram seeds (GG-3) from AAU, Anand in the salt affected lands of the Village-Gudel, Taluka-Khambhat, District-Anand, Gujarat. The 45 farmers got benefitted from the program and increased the crop yield from the salt affected lands. The organic fertilizers from AMUL were given to the farmers having salt affected lands for improvement in the soil health and crop yield. The farmer's income has increased from the salt affected lands.



### **Animal Health Camp for Livestock Health & Improvement under SCSP**

The animal health camp was organized in the village-NavagamVanta, Taluka-Khambhat, Gujarat. Total 75 SC farmers family got benefitted by the program. The mineral mixture and medicines were given by centre based on the advice of the veterinary officers from the state government. The animal health and milk yield of animal has increased due after the continuous effort of the centre in the village. It has also enhanced the farmer's income in the village.

### **Achievements under Tribal Sub-Plan program**

A total of nineteen selected tribal villages/hamlets spread over in sixteen Gram Panchayats covering twelve districts of ten states in the country have been chosen for demonstrations on various natural resource conservation technologies besides societal development-oriented activities and capacity building for the welfare of weaker farming communities. Improving crop production, income generation and resource conservation benefitting upliftment of tribal communities who are largely depending on traditional farming and animal husbandry, etc. was major focus at Institute Headquarter, Dehradun (Uttarakhand), and its five Regional Centres at Ballari (Karnataka), Kota (Rajasthan), Koraput (Odisha), Udhagamandalam (Tamil Nadu), and Vasad (Gujarat).

Considering the prevailing farming situations and problems, many interventions for conservation of natural resources to improve agricultural production have been implemented by IISWC, Dehradun and its 5 Research Centres to benefit Scheduled tribe Communities who largely depend on traditional farming and animal husbandry, etc. and Natural Resource Management. It was started in 16 selected Scheduledtribe villages/hamlets spread over 11 Gram Panchayats, covering 6 blocks / Talukas, in 6 Districts of 6 States in the Country. Total number of families covered under TSP programme is 1018. Technological demonstrations and capacity building for holistic improvement of crop production, income generation towards resource conservation, and upliftment of Scheduled tribe farmers were major focus.

### **Financial achievements under TSP**

Total budget of Rs. 67 lakhs (Rs. 54 lakhs in operational + Rs. 13 lakhs in capital) was allocated and utilized for implementation of planned activities in selected tribal villages adopted during the year 2023-24 .The major expenditure of Rs. 21.6344 lakhs (32.29%) incurred on soil and water conservation practices / technologies developed by ICAR-IISWC at Dehradun and its regional research centres followed by Rs. 9.9402 lakhs (14.84%) on various demonstrations of technologies Rs.8.49 lakhs (12.68%) on agriculture implements, Rs. 7.18 lakhs (10.72 %) horticulture and forestry activities, Rs. 6.77 lakhs (10.11%) on other activities, Rs.5.85 lakhs (10.11 %) on crop production, Rs. 5.39 lakhs (8.05 %) in Capacity building/Awareness camp/Exhibition/Exposure visits, etc., and Rs. 1.75 lakhs (2.61 %) on income generation activities (Table 2). About 3741 number of resource-poor farmers benefitted from these activities with the maximum under the capacity building/awareness camp/exhibition (1339) followed by other activities (457), soil and water conservation measures, horticulture and forestry activities (380), demonstrations of various technologies (377), crop production (365), agricultural implements (326) and income generation activities (65) beneficiaries. The total area covered under various activities was 595.2 ha and the maximum area covered under the soil and water conservation measures was 33.5% followed by 27.6% for crop production based activities (Table 2).

### Physical Achievements

**Table2: Activities wise physical and financial achievements under TSP Programme during financial the year 2023-24**

| S. No. | Activities under SCSPProgramme  | Unit | Qty.   | Area covered (ha) | Budget utilised ( lakhs) | Beneficiaries / Farmers (Nos.) |
|--------|---|------|--------|-------------------|--------------------------|--------------------------------|
| 1.     | Capacity building / Awareness camp / Exhibition / Exposure visits, etc. | No.  | 20     | 00.0              | 5.3903                   | 1339                           |
| 2.     | Demonstrations  | No.  | 1306   | 106.0             | 9.9402                   | 377                            |
| 3.     | Agriculture Implements  | No.  | 366    | 16.0              | 8.4928                   | 326                            |
| 4.     | Soil and Water Conservation Activities                                  | No.  | 231    | 199.5             | 21.6344                  | 432                            |
| 5.     | Income Generating Activities  | No.  | 5      | 00.0              | 1.7500                   | 65                             |
| 6.     | Crop Production   | Kg.  | 6454   | 164.0             | 5.8464                   | 365                            |
| 7.     | Horticulture and Forestry Activities                                    | No.  | 114460 | 92.7              | 7.1790                   | 380                            |
| 8.     | Others  | No.  | 21223  | 17.0              | 6.7660                   | 457                            |
|        | <b>Total</b>  |      |        | <b>595.2</b>      | <b>66.9992</b>           | <b>3741</b>                    |

### Capacity Building Programs under TSP

The Kisangosthi was organized in Bhadrolikhurd-Karada watershed, Taluka-Kalol, District Panchmahal, Gujarat to create awareness about the water management and efficient utilization of harvested water in the watershed. Total 75 tribal farmers got benefitted from this activity under TSP program. The tribal farmers were also distributed 1000 litres water tank for kitchen gardening and domestic use. The kitchen gardening will enhance the farmers income by producing vegetables and fruits for their own consumption and sale of surplus vegetables in the local market.

### Soil and Water Conservation Works under TSP

The drop structure was constructed in drainage channel for water harvesting, groundwater recharge and supplemental irrigation through lift irrigation in Bhadrolikhurd-Karada watershed, Taluka-Kalol, District-Panchmahal, Gujarat. Total 65 tribal farmers got benefitted from this activity under TSP program. The drop structure is expected to harvest 750 cu. m. and 1200 cu. m. per year in one filling. The water harvested will bring an additional 35 ha area under assured irrigation during the Rabi season. The water harvested will also recharge the groundwater in the watershed.





### Water Resource Development Works under TSP

The lift irrigation system with underground pipeline system was installed in Bhadrolikhurd-Karada watershed, Taluka-Kalol, District-Panchmahal, Gujarat. Total 55 tribal farmers got benefitted from this activity under TSP program. The underground pipeline network of 950 meters was laid in the farmer's field with outlets for saving the water losses in field channels. The lift irrigation system with underground pipeline network will bring an additional 20 ha area under assured irrigation during the Rabi season. The group of farmers were given 8 HP Diesel pump set for the lift irrigation system, which will be managed by the user group. Water harvesting structures renovated through repair of major earthen bund in large check dam in the drainage channel. The water harvesting of about 5200 cu. m. is expected in one filling behind the check dam which will provide additional storage of runoff for supplemental irrigation and groundwater recharge in the watershed. The earthen bund was also planted with *Thur* and bamboo plantation for protection from grazing animals. This activity will benefit about 85 ST farmers family residing nearby the drainage channel.



Dug wells used for drinking and domestic needs were renovated and cleaned for providing safe drinking water to the ST Farmer's families residing in the watershed. Total 05 Dug wells were renovated and about 03 Dug wells constructed in the watershed for drinking and domestic needs of the ST families in the watershed. The renovation has increased the availability of safe drinking water in watershed benefiting about 40 ST farmers family. One

Dug wells renovated was used by the primary school of the village for drinking purpose of school children's of the villages in the watershed.



The 40 ST farmers were distributed 500 meters 75 mm sprinkler irrigation pipes for providing irrigation to crops, vegetable and fruit crops in their kitchen garden along with diesel pump set for lift irrigation from water harvesting structures created in the watershed. This activity ensured lifesaving irrigation during the critical stages of crop and increased the crop yield by 30-40%. The farmer's income got increased by 10-20% due to increased crop yield, vegetable and fruit yields from kitchen garden besides bringing an additional 15 ha area under assured irrigation during Rabi crop.

#### **Climate Resilient Crop Production System under TSP**

The 45 ST farmers were distributed Hybrid HY varieties of maize seeds developed by Anand Agricultural University, Anand. The bumper growth was recorded in the yield of Maize in the farmer's field. The yield was increased by 50% as compared to the conventional seeds used by the farmers previously. The farmer's income got increased by 25% due to increased crop yield and balanced fertilizer inputs recommended by the centre. This activity benefitted about 45 ST farmers and the less disease and pest infestation was observed by the farmers.



#### **Farm Mechanization & Post harvest Interventions under TSP**

The 60 ST farmers were distributed 1000 litres water tank for domestic needs and providing the supplemental irrigation to the vegetable and fruit crops in their kitchen garden. The 100 kg capacity grain storage bins were given to 55 ST farmers family for safe storage of grains

and pulses for their own consumptions and reduce post-harvest losses. The farmer's income got increased by 10% due to increased vegetable and fruit yields from kitchen garden and reduction in post-harvest losses in the grain and pulses.

### **Entrepreneurship and Skill Development for Livelihood Security under TSP**

One model nursery was created in Bhadrolikhurd-Karada watershed, Taluka-Kalol, District-Panchmahal, Gujarat to provide good quality planting material to the ST farmers and also increase the farmer's income. About 10 farmers were given skill development training on the operation and maintenance of the nursery and different method of vegetative propagation at ICAR-CIAH, CHES, Vejalpur, Panchmahal. The 40 tribal farmers were also distributed planting material and organic manures for initiating the work of model nursery. The activity is expected to increase the farmer's income by 10-20%.



### **Animal Health Camp for Livestock Health & Improvement under TSP**

The animal health camp was organized in the Bhadrolikhurd-Karada watershed, Taluka-Kalol, District-Panchmahal, Gujarat. Total 65 ST farmers family got benefitted by the program. The mineral mixture and medicines were given by centre based on the advice of the veterinary officers from the state government. The animal health and milk yield of animal has increased due after the continuous effort of the centre in the village. It has also enhanced the farmer's income in the village.



### **Demonstrations Organized under SCSP and TSP**

Total 58 demonstrations were conducted under SCSP / TSP programme in SCSP / TSP villages, details of some significant demonstrations are given as below:

#### **▶ Demonstration of Gypsum Amendment on Mustard Crop**

Oilseed crops, particularly, mustard and soybean have high sulphur requirement. Among many agronomic factors responsible for low yield is imbalanced and injudicious use of fertilizers also limits the crop production. Soil nutrient analysis of the study area showed higher sulphur deficiency in all the arable lands. The gypsum based technology was demonstrated to overcome sulphur deficiency and improve oilseed productivity. Under SCSP programme, five field demonstrations for mustard crop were planned in Kareriya village of Bundi district of Bhadakeda watershed. Application of gypsum amendment is recommended as it will not only supply sulphur nutrient, but as soil ameliorant would promote soil aggregation and enhance soil physical structure. Results of the gypsum based technology after two years indicated improvement in mustard grain yield by 12-13% and provided higher net returns over farmer's practices. Post-harvest soil analysis showed significant improvement in available sulphur content. The field demonstration of gypsum can benefit farmers in both short and long-term benefits, by improved crop production and soil physical-chemical properties.

#### **▶ Contour Furrow Technology Demonstrations**

A conservation measure in medium-deep black soils of South-eastern Rajasthan. A best bet technology for rain water conservation and higher production in South-eastern Rajasthan. The contour furrows create an additional surface storage capacity of 11.25 mm/ha and reduce runoff by 22% and soil loss by 1.4 t/ha/year the net returns under contour furrow treatment are 129% higher than the farmer's practices. Furrows were created across the field slope.

#### **▶ Demonstration of Nutri-gardens Fruit and Vegetable based Nutri-gardening**

To provide the nutritional food security, fruit based nutri-gardening is the best option to solve the malnutrition problems of the rural areas. Under these activities one fruit plant of each species viz. guava, lime, pomegranate, karonda and lehsua were planted at farmer's field/backyard garden of SCSP beneficiaries. These fruit species have untapped source of minerals and vitamins which are capable to fulfil the nutritional requirement of the human body. These are suitable species for semi-arid region of South-eastern Rajasthan. Malnutrition is a serious problem amongst rural tribal. To provide the nutritional food security, vegetable based nutri-gardening is the best option to solve the malnutrition problems of the rural areas. Nutri-

garden is not only for providing nutritional food security but also generating the additional income for the villagers. Under these activities five vegetable demonstrations with different vegetables (namely; Spinach, carrot, radish, tomato, brinjal, onion, sugar beet, chilly, fenugreek and vegetable pea) organised at the farmer's field of TSP beneficiaries. These vegetables have untapped source of minerals and vitamins which are capable to fulfil the nutritional requirement of the human body and boost up the immunity to protect serious diseases.

#### ▶ **Conservation Agriculture Technology Demonstrations**

Conservation agriculture technology demonstration was conducted under the programme TSP. Conservation agriculture technology is from recently concluded project which is suitable for reducing production cost vis-à-vis other advantages of sustainable production. In this technology, mustard is sown with the help of zero till seed cum fertilizer drill after controlling the standing weeds with suitable herbicides.

#### ▶ **Training on Cultivation of Millets for Resource Conservation and Nutritional Security**

ICAR-IISWC, Research Centre, Udthagamandalam organized one day training cum exhibition programme on "Importance of Millets in Resource Conservation, Value addition and its Nutritional Benefits" under TSP to commemorate the International Year of Millets (IYM)-2023. The technical sessions and the exhibition of different soil and water conservation technologies suitable for millets cultivation in the tribal dominated area were explained. Exhibition of various millet-based products such as millet biscuits, health drink, noodles, vermicelli, cake/sweet mix and cookies was made. Flour making machine along with improved millet seeds like *ragi*, *bajra* and little millet were distributed in groups under the TSP programme to promote millet production and consumption.

#### ▶ **Demonstration on Improved Vegetable Crop Production**

Demonstration of improved vegetable production like French beans was taken up for improving the nutritional and farm income of Kotagiri tribes under TSP. This resulted in crop diversification reducing the income risk to the small and marginal farmers.

### **Conclusion**

The SCSP and TSP programs has addressed several problems of natural resource management such as soil erosion, water scarcity, waterlogging, improper drainage mechanism leading to the rise of groundwater table and movement of salt to the surface, sea water intrusion, decline of ground water quality are major degradation processes threatening

sustainability of production potential different ecosystem of India. Due to lack of awareness among the socially backward and resource poor farmers and scanty resources in these areas, the rural SC and ST communities are poorly equipped to face the challenge of unfriendly environmental conditions. The poor crop yield and water scarcity reported from several regions during last decade resulting to poor crop yield and even failure are indicative of grievous situations which needs immediate attention for taking right steps to solve the issues through natural resource management programs.

The water resource development and conservation measures applied these villages through SCSP and TSP programs were highly ameliorative cum remunerative in nature. The construction and renovation of water harvesting structures has enhanced the farmer's capabilities for irrigation to crops. The crop diversification with improved cropping practices these ameliorative effect can be enhanced to quickly recover the investment made towards soil and water conservation measures in degraded lands. However, strengthening existing water harvesting structures and developing additional village ponds with judicious utilization of water resources has effectively reduced effect on the rural livelihoods. It is clear from the rural developmental works through SCSP and TSP that irrespective of male or female farmers, improved level of socio-economic status, knowledge, risk taking ability and positive attitude were positively and significantly correlated with the farmer's participation in planning phase. Thus, right from beginning (rapport building phase), care should be taken, to involve those who are low on various independent variable, to get the variety of ideas and experiences from every strata of the village society, a prime requisite for perfect participatory planning, development and finally management of natural resources for benefit of the society.

---

## Participatory Rural Appraisal (PRA) techniques for watershed planning

*K N Ravi*

*Scientist (Agricultural Extension), ICAR-Indian Institute of Soil and Water Conservation,  
Research Centre, Ballari-583104*

---

### Introduction

Participatory Rural Appraisal (PRA) is a research technique developed in early 1980s as an alternative and complement to conventional sample survey. PRA is a way of learning from and with farmers to investigate, analyse and evaluate constraints and opportunities and to formulate research plan to address the problems. PRA is a systematic, semi-structured activity conducted on site, by a multidisciplinary team. In this connection Participatory Rural Appraisal (PRA) is considered one of the popular and effective approaches to gather information in rural areas and an important tool to find location specific problems and researchable issues to come up with possible solutions for short and long-term benefits. PRA is a good exposure for the budding scientists to understand the problems of the farmers, learning together with villagers about the village and allows them to think individually in his/her area of interest for necessary intervention. The aim of PRA is to help strengthen the capacity of villagers to plan, make decisions, and to take action towards improving their own situation. PRA is based on village experiences where communities effectively manage their natural resources.

PRA is a methodology of learning rural life and their environment from the rural people. It requires researchers / field workers to act as facilitators to help local people conduct their own analysis, plan and take action accordingly. It is based on the principle that local people are creative and capable and can do their own investigations, analysis, and planning. The basic concept of PRA is to learn from rural people.

### Participatory Rural Appraisal (PRA)

Chambers and Conway (1992) developed participatory rural appraisal (PRA) to improve the understanding of ethics between scientists and farmers. The technique evolves local information to manage the existing natural resources in agricultural systems, health, and socioeconomic issues in societies needing prompt attention (Chambers and Conway, 1992; Loader and Amartya, 1999; Mohammed et al., 2023) PRA techniques origin from many sources, the most direct is Rapid Rural Appraisal (RRA) from which it has evolved. RRA itself began as a response in the late 1970s and early 1980s to the biased perceptions

derived from rural development tourism (the brief rural visit by the urban-based professional) and the many defects and high many forms of diagramming, derived from agro-ecosystem analysis (Gypmantasiri et al., 1980; Conway, 1985; Chambers, 1994b). PRA has much in common with RRA but differs basically in the ownership of information, and the nature of the process: in RRA information is more elicited and extracted by outsiders as part of a process of data gathering; in PRA it is more generated, analyzed, owned and shared by local people as part of a process of their empowerment.

### **Principles of PRA**

The principles of PRA have evolved over time. As already discussed PRA techniques origin from many sources, the most direct is Rapid Rural Appraisal (RRA) from which it has evolved. Hence both have shared principles but varied in approach of rapid appraisal (RRA) to more of participatory in mode. The Chambers (1997) has listed the following principles.

1. **Listening and Learning:** PRA is based on the principle of listening and learning through participatory interactions and learning progressively. The local people knowledge, their experience, their history and culture, their views and ideas were given due importance.

2. **Offsetting Biases:** PRA aims at offsetting biases, which means the appraisal must not be rushed and process should not be unduly hurried or rushed. In order to offset such biases, PRA, encourages relaxed listening and learning, seeking participation from rural people. This process should try to have involvement-of the poorest people, women, and disadvantaged groups in remote areas in the planning process.

3. **Seeking Diversity:** PRA involves learning from diverse conditions and different actors. It consults with more of difference rather than looking for representativeness of results or data collected. It is looking for diverse events, different processes and forces, which help in understanding of issues from different perspectives. For any analysis, greater the diversity, better is the understanding of “reality”.

4. **Triangulation /Cross checking is essential:** The process of Triangulation/cross-checking is an important principle of PRA for minimizing errors and doing mid-way corrections.

5. **Optimal Ignorance:** it means capturing information about things that are relevant to the study’s specific aims and objectives rather than collecting information that is not relevant to the subject matter of the study.

6. **Multi-disciplinary Team:** The scientific team conducting PRA must have fairly broad base, meaning thereby inclusion of scientists of all important disciplines relevant to the area



of study. It is also important to have female team member, so that, rural women could be effectively involved in the appraisal exercise.

The above principles are shared by RRA and PRA (Chambers, 1994b). However, what distinguish RRA from PRA is that PRA puts special stress on offsetting biases, and the associated changes in outsiders' behavior. In addition, PRA in practice manifests four further principles including

**7. They do it:** it means facilitating investigation, presentation analysis, and learning by local people themselves, so that they generate and own the outcomes, and also learn.

**8. Self critical awareness:** PRA emphasis that facilitators must continuously and critically examine their own behavior and avoid dominant behavior.

**9. Sharing:** PRA emphasis on sharing of information and ideas between local people, between them and outsider facilitators, and between different practitioners and experiences between different organizations, regions and countries.

### **PRA for Natural Resource Management**

PRA approaches and methods have evolved and spread so fast that any inventory is likely to be incomplete. In early 1994, most of the known applications of PRA can be separated into four types of process, and into four major sectors (Chambers, 1994a). The four major types of process are, i) Participatory appraisal and planning, ii) Participatory implementation, iii) Monitoring and evaluation of programs, iv) Topic investigations, v) Training and orientation for outsiders and villagers. The four major sectors of PRA applications are i) Natural Resources Management ii) Agriculture iii) Poverty and social programs and iv) Health and food security.

As PRA is applicable to almost all domain areas of agriculture and its allied sectors to investigate, analyse and evaluate constraints and opportunities and to formulate research plan to address the problems. However, their application in watershed planning and development is well documented and a successful in enhancement of participation of people in watershed programmes.

### **Application of PRA in participatory watershed planning and management**

PRA basically a bottom to top approach of learning rural life with the people, for the people and by rural people. Due to active participation of community members as well as scientists, PRA has become a useful method to focus attention on rural people, their livelihood and relationship with social and economic factors. It is a good technique to help the community

members make an appraisal of their own livelihoods and issues related to it within the watershed. Diverse information is collected during PRA using a number of techniques. This information is verified by triangulation among various key informants (KI's) in addition to on-site observation by the team members. The complexities of problem involved in agriculture can be understood through PRA and hence, it is a system approach for systematic and rapid collection of information. The principle and methods of PRA was adhered for gathering information on various topics in appraisal of Natural Resources. Before starting of PRA activities, the report building and collection of basic information of watershed is essential.

### **Rapport Building**

Rapport building is an effective communication tool carried out at the beginning stage of any developmental activity. Rapport building with leaders and villages of watershed is at most important to sensitize them the purpose for which the team is visited must be clearly explained and asked for their cooperation before starting of any interventions or developmental planning.

### **Basic information about the watershed**

Documentation of the Basic information about the watershed should be carried out by visiting Panchayath, School, FPO and other key social organizations in the village and through Focus group discussion with the People in the watershed to get first hand information about the watershed. Generally the following details will be a) General description of watershed, b) Climate, c) Soil, d) Crop and Cropping system of watersheds, d) Drainage, e) Vegetation and f) Socio-economic condition of the watersheds. However, the information may be crosschecked with the data gained or obtained from the other PRA tools and techniques at the end of the PRA process and inclusion of missing data and modifications may be done. Once the rapport building and basic information about the watershed is collected, we have to start PRA in the watersheds.

### **PRA methods can be broadly classified into three categories**

Space related/ Spatial PRA tools, Time related PRA tools and Relation related PRA tools based on their approaches and focus of analysis. We are enlisted some major PRA tools and techniques used for participatory appraisal and planning of Natural Resource Management for watershed development below.

## A. Space related PRA tools

### 1. Social Map

**Purpose:** Most important PRA technique to be conducted in watershed was social mapping of the villages in the watershed. The purpose of generating social map in watershed is for depiction of habitation patterns and the nature of housing and social infrastructure: roads, drainage systems, schools, drinking water facilities, etc.

#### Applications:

1. Social map majorly reflects local people perceptions of the social dimensions with their reality with the high degree of validity.

2. Social Maps helps to acquire spatial distribution of habitats, type of communities exists in the watershed, village infrastructure like road, houses, drainage and institutions located in watershed,

3. it help the team to understand the leadership patterns, value systems, social interactions,

cooperation, competition, conflict, assimilation and accommodation and other social aspects like social norms, folkways, mores, social evils like dowry, alcoholism, child labour etc. in the watershed village.



### 2. Resource Map

The resource map will be drawn with the help of information collected through key informants on various aspects of resources of the village.

**Purpose:** A resource map of a watershed is an illustration of both the natural resources and man-made resources needed for its natural resource conservation and agricultural development in the watersheds.

### Applications:

i) The map entails information about the natural as well as man-made resources of the watersheds including land area available for agriculture, vegetation, drainage system, soil and waters conservation structures (check dams, percolation tanks, Nala bund etc), water resources like open wells, borewells, irrigation system, livestock, transportation facilities, communication facilities, manpower, etc.

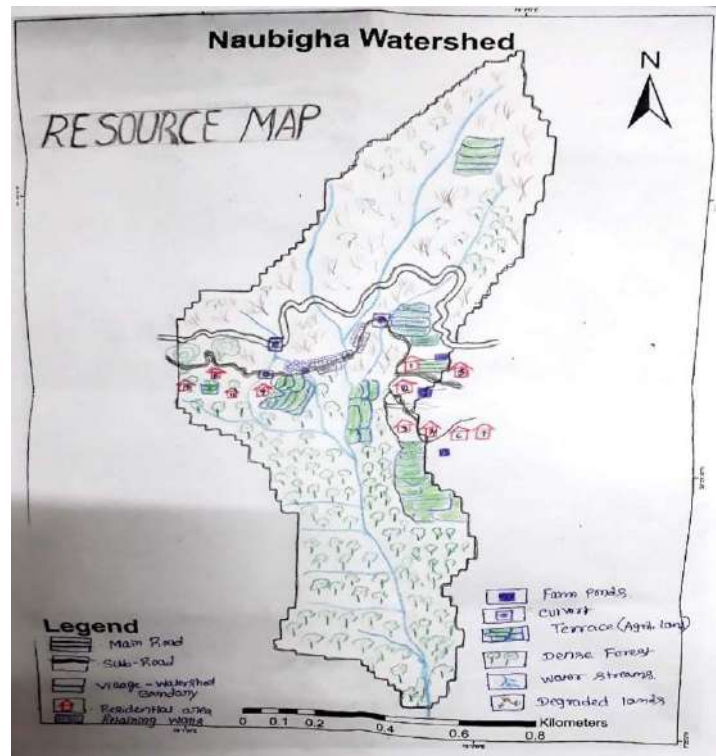

ii) Developing a resource map is not only helpful in knowing and understanding the watershed resources but also in analysing the problems faced by the farmers. This will eventually help in bringing mitigation plans and measures for their problems and finally bridge the gap of resource potential and productivity.

Note: While the social map focuses on spatial distribution of habitation, community facilities, roads, temples, etc., the resource map focuses on the natural resources in the locality and depicts land, hills, rivers, fields, vegetation, etc. In the other hand, resource map will depict the distribution of natural and man-made resources in the watershed.

### 3. Transect walk

Watershed transect is another PRA method used to explore the spatial dimensions of people's realities. It has been popularly used for natural resource management.

**Purpose:** The watershed transect helps the team to provide a cross-sectional representation of the different agro-ecological zones and their comparison against certain parameters including topography, land type, land usage, ownership, access, soil-type, soil fertility, vegetation, crops, problems, opportunities and solutions (Sontaki et al., 2019).

**Application:**

- i) Appraisal of natural resources in terms of status problems and potential in the watershed
- ii) Verification of problems or issues raised during other PRA exercise particularly during social mapping, natural resources mapping, etc.
- iii) Transact walk used to cross check the information or data collected from other PRA techniques and also helps in planning interventions in the watersheds.
- iv) Transact walk also useful tool for monitoring and evaluation of watershed interventions and projects.

**Table 1: Transact map of Naubhiga watershed, Dehradun, Uttarakhand**

| Parameters             | High hills                      | Mid hills  | Down hills                          |
|------------------------|---------------------------------|--|-------------------------------------|
| <b>Vegetation</b>      | Lantana, Redi                   | Lantana, Timal, Sain, Khadki,  | Sal, sain , rohini,                 |
| <b>Grasses</b>         | Lantana, Dub                    | Lantana, Dub, Goat weed  | Lantana, Goat weed                  |
| <b>Soil</b>            | Gravely                         | Well terraced , Gravely, Low WHC,                                    | Poorly terraced and un irrigated    |
| <b>Crops</b>           | Paddy, maize                    | Paddy, maize, wheat, Mustard, Tur, Lentil                            | Paddy, maize, wheat,                |
| <b>Horticulture</b>    | Mango, Guava                    | Mango , banana, onion, Guava, Peach, Papaya ginger, Turmeric, Citrus | Mango, papaya, citrus, Guava, Anola |
| <b>Livestock</b>       | Goat , Sheep                    | Buffalo, Cow, goat, bullock  | goat, bullock Cow, Sheep            |
| <b>Water Resources</b> | seasonal water springs          | seasonal water springs   | Perennial water springs             |
| <b>Land use</b>        | Forest, abandoned agri land     | Habitation , agriculture, Horticulture, Agro forestry                | Agriculture , habitation, Forestry  |
| <b>Problems</b>        | Scarcity of vegetation, erosion | Scarcity of water  | Erosion problems                    |

Note: The resource map provides a bird's eye view of the watershed with focus of natural resources. A transect, however depicts a cross sectional view of the different agro-ecological zones within the watershed (example: upper reach, middle reach and lower reach) and provides a comparative assessment of the each zones with different parameters.

## 4. Mobility Map

**Purpose:** Mobility map purpose is to reveal the ease of availability of various inputs/purposes and their accessibility to the villagers.

### Application:

i) The mobility map shows the direction, frequency, mode, the cost incurred and the purposes for which the villagers have to travel outside the village/watershed for various agricultural, social, educational, health and entertainment purposes.

ii) Mobility map will help us know the purpose, distance, mode of transport and frequency of visit by village people located in watershed different places.

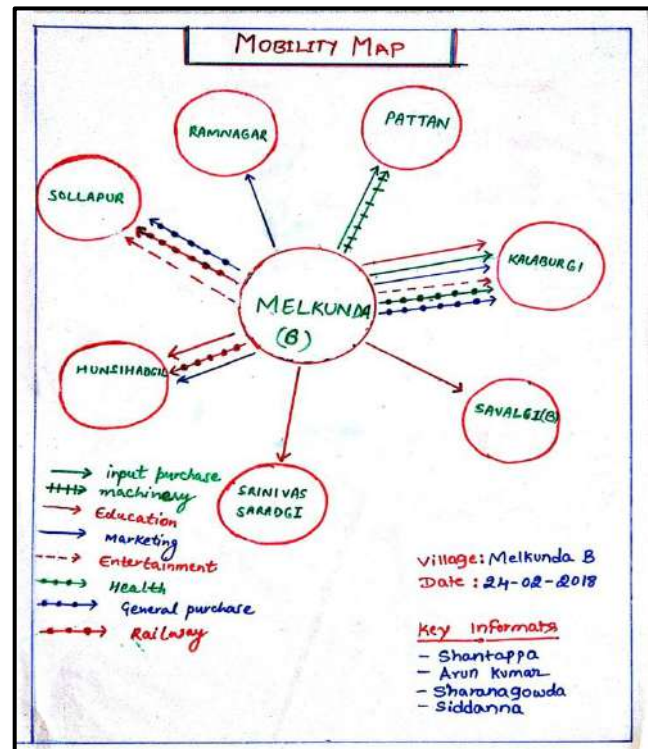

## B. Time related PRA tools and Techniques

### 5. Historical Timeline

Historical timeline PRA technique is used to explore the temporal dimensions of watershed from historical perspective.

**Purpose:** Historical timeline capture the chronology of events as recalled by local people. It will provide a glance of sequential aggregate of past events happened in the watershed over time.

### Application:

i) It provides the historical landmarks of a community infrastructure, major climatic events, developmental works, innovations and establishment of various social institutions in the watershed.

ii) it will help the multidisciplinary team to understand the progressive development of villages in the watershed. Also provide the how well the villagers accept or reach of the innovations and agriculture technologies in the villages of watershed.

Note: We have to collect the events of the past as perceived and recalled by the people themselves and the while selecting the key informants for this exercise one should select aged people having knowledge of past development in the village.

**Table 2: Historical timeline of watershed area**

| Year     | Description of Events   |
|----------|---|
|          | <b>Infrastructure Development</b>   |
| 1970     | Village Established   |
| 1989     | Road was constructed  |
| 1990     | Water resources were developed for drinking water/irrigation water.                               |
| 1992     | Village was Electrified   |
| 1992     | Middle School   |
| 2002     | Panchayat bhawan/Temple/Mosque was constructed.   |
|          | <b>Use of Information Sources</b>   |
| 1982     | 1 <sup>st</sup> Radio.  |
| 1992     | First T.V. was purchased in village. Use of Improved breed of livestock                           |
| 2007     | 1 <sup>st</sup> Mobile Phone was purchased in village.  |
|          | <b>Natural calamities</b>   |
| Frequent | Occurrence of landslides.   |
| 2007     | Occurrence of <i>insect/ pest/ diseases in crops/ livestock</i> .                                 |
|          | <b>Agricultural Development</b>   |
| 2009     | Started use of improved breeds of animals.  |
| 2010     | Water harvesting structures were Developed.   |
| 2010     | Started use of chemical fertilizers/ agri chemicals.  |
| 2012     | Started use of improved varieties.  |
| 2012     | Started use of improved farm implements/ machinery.   |
| 2012     | Other income generating activities (Mushroom, bee – keeping, Poultry, Piggery etc.) were started. |
| 2013     | Check dams/ retaining walls were constructed.   |

Source: PRA exercise conducted at Naubhiga Watershed, Dehradun

## 6. Trend Analysis

Trend Analysis/Time trend is a simple PRA technique, usually depicted in the form of a graph (bar/line) to show the trend of crop/animal production, commodity prices, human/cattle population etc.

**Purpose:** The specific purpose of this tool is to identify the changes/fluctuations that have occurred over a period of time in the variables influencing village life.

### Application:

i) Trend Analysis can be applied to showcase shift in area under different crops, productivity, price, change in vegetation, erosion, availability of irrigation water etc in the watershed.

ii) The local people have a good understanding of the present situation and the changes that have taken place over the years.

iii) Trend analysis can also provide a good idea of the quantitative changes over time in different aspects of village life, such as yields, population, livestock population, the number of trees, area under cultivation, rainfall, etc (Sontaki et al., 2019).

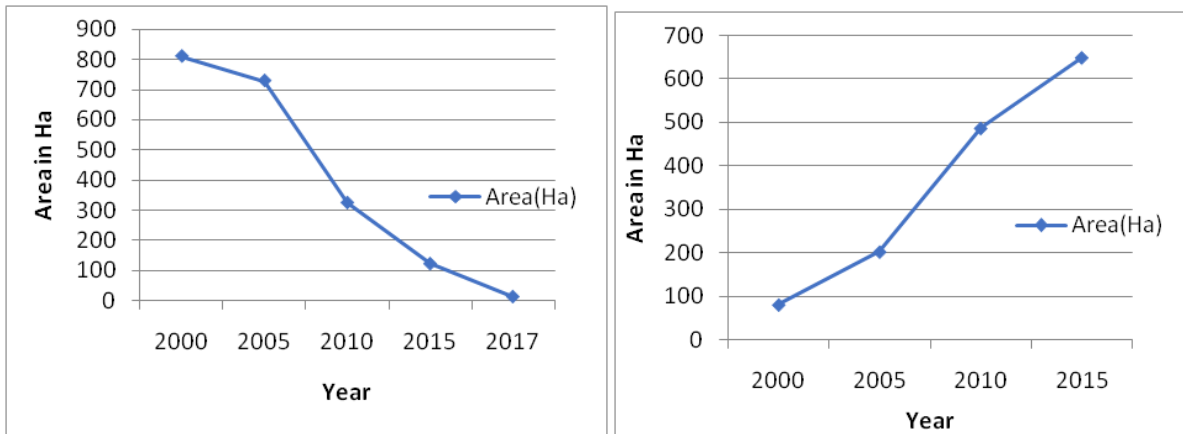

Change in the productivity of major crops (Fig 1. Groundnut and Fig.2 Pigeon pea) in Melkunda village, Kalaburgi district, Karnataka (Area Trend)

**Relation related PRA tools and Techniques**

**7. Venn diagram/Chapathi Diagram**

The Venn diagram also called as chapatti diagram. It can be drawn along with people to understand inter-linkages, interactions and relative importance between the various organizations and individuals to community/villages in watershed.

**Purpose:** Venn diagram shows existing institutions, organizations, groups and important individuals found in the village as well as the

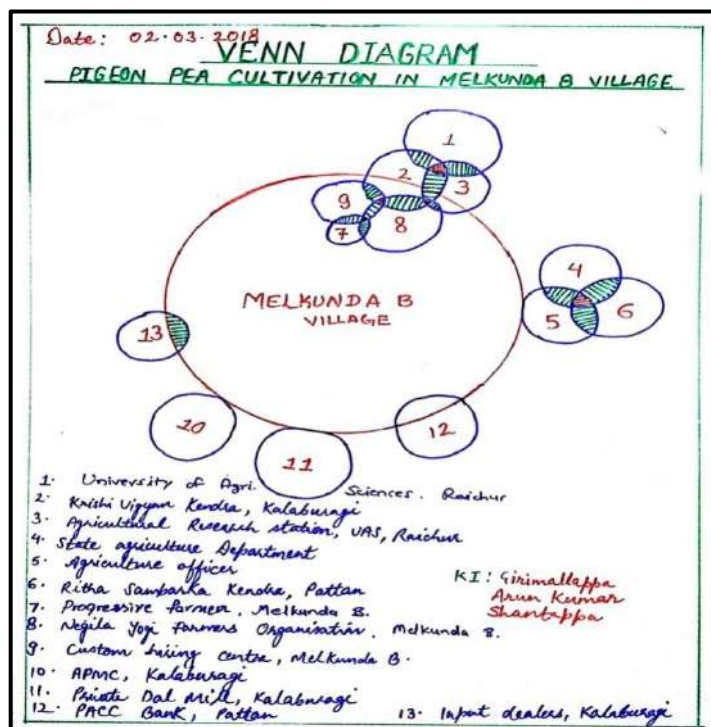



villagers' view of their importance in the community.

### Applications:

i) Venn diagram indicates the level of contact and cooperation between organizations and groups located within and outside the watershed.

ii) The importance of a institution to stakeholders is judged in terms of the size of the circle. Further, the interactions among various stakeholders are indicated by the overlapping of corresponding circles, more interaction means more overlapping of circle.

iii) It also shows various organizations, groups and important individuals found in the village as well as the villager's view on their importance in the community.

iv) It highlights potential conflicts between different watershed stakeholder groups.

## 8. Problem Identification and Prioritization

The problem identification technique was used to identify and prioritize the problems prevailing in agricultural sector in the watershed. There are different techniques used to prioritize problems in the watershed including Frequency, garret ranking and Rank based quotient method. The following examples of simple frequency method of prioritization of problems were given in the table. The team must enlist the problems after discussion with the local people and identify the sample population to indicate the problems faced by them in agriculture and allied livelihoods. The frequency against each problem is summed and based on highest people response the problem was prioritized (Ravi et al., 2020).

### Simple Rank frequencies for prioritization of different problems

| S. No. | Problem Identified              | Farmers Perception |    |     |    |   |    |     | Total | Rank |
|--------|---------------------------------|--------------------|----|-----|----|---|----|-----|-------|------|
|        |                                 | I                  | II | III | IV | V | VI | VII |       |      |
| 1      | Lack of drinking water          | 2                  | 1  | 3   | 1  | 2 | 1  | 1   | 11    | X    |
| 2      | Unemployment                    | 3                  | 4  | 6   | 3  | 5 | 3  | 3   | 27    | VIII |
| 3      | Land slides                     | 4                  | 3  | 4   | 3  | 2 | 2  | 4   | 22    | IX   |
| 4      | Scarcity of Irrigation Water    | 8                  | 8  | 7   | 6  | 9 | 8  | 8   | 54    | I    |
| 5      | Low milk yield                  | 4                  | 5  | 3   | 4  | 6 | 3  | 4   | 29    | VII  |
| 6      | Low productivity of field crops | 6                  | 7  | 9   | 8  | 6 | 7  | 9   | 52    | II   |
| 7      | Lack of modern inputs           | 6                  | 5  | 3   | 4  | 8 | 5  | 4   | 35    | VI   |
| 8      | Wildlife attack on crops        | 9                  | 6  | 5   | 7  | 3 | 6  | 5   | 41    | IV   |
| 9      | Scarcity of fuel & fodder       | 1                  | 2  | 1   | 2  | 1 | 2  | 2   | 11    | X    |
| 10     | Transportation                  | 5                  | 7  | 8   | 8  | 7 | 7  | 6   | 48    | III  |
| 11     | Market                          | 7                  | 3  | 4   | 8  | 4 | 7  | 7   | 40    | V    |

## 9. Problem-Solution Tree (Cause effect diagram)

Problem-Solution Tree (Cause effect diagram) also popularly known as fishbone or Ishikawa diagram. it focuses on the causal factors of a phenomenon, activity, or problem, and the effects thereof.

**Purpose:** The cause effect diagram present visually the causes, effects and their inter-linkage with the problem, which helps in arriving at an in-depth understanding of a particular topic, and provide scope for analysis and subsequent action by the local people (Sontaki et al., 2019).

### Application:

- i) Helps to understand the causes of a particular problem identified in the watershed and also possible solutions to overcome the problem using participatory interaction.
- ii) The local people themselves discuss and find a most appropriate solution with the guidance of the facilitator.
- ii) This exercise helps local people and facilitators to understand root cause of a particular phenomena and possible solutions or intervention to be taken up through watershed activity to reduce its severe effects.

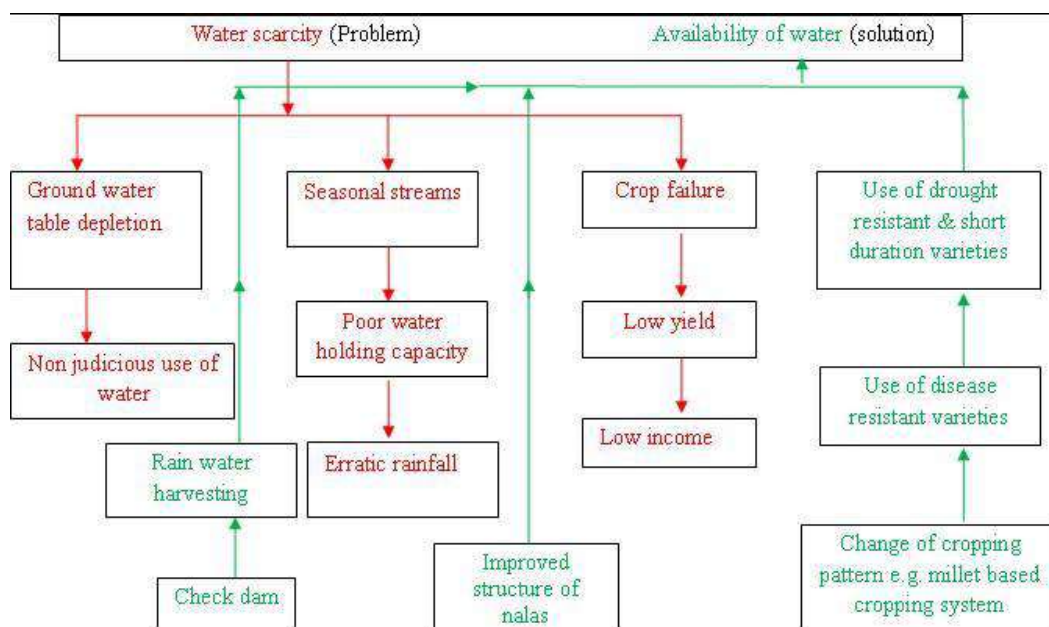

## Action Plan

A suitable action plan will be prepared based on the objective of the project under which PRA was conducted. Action plan was prepared to meet the problems faced by farmers and recorded in the watershed for example severe water scarcity, low productivity, poor drainage, high soil erosion and other problems in the watersheds/community (Ravi et al. 2020). Based on that watershed intervention will be planned including various execution plans- who, what, how and where and budgetary plans for better outcome

## Conclusion

Evidence shows high validity and reliability of information shared by local people through PRA compared with data from more traditional survey methods (Chambers, 1994b) which require more time and resources. The strategy for watershed development is based on recognition of the need for location specific conservation and livelihood plans which are sustainable and valuable for local people. Hence, PRA techniques will provide action oriented planning and management of watersheds and ensure greater involvement and participation of the stakeholders in to the program to ensure long sustainability of watersheds and its interventions.

## References

- Conway, G., 1985. "Agroecosystem analysis," Agricultural Administration, Vol. 20, pp. 3 1-55.
- Chambers, R., Conway, G., & Brighton Institute of Development Studies. (1992). Sustainable rural livelihoods: practical concepts for the 21st century (Vol. 296). Brighton: Institute of development studies.
- Chambers, R. (1994a). The origins and practice of participatory rural appraisal. World development, 22(7), 953-969.
- Chambers, R. (1994b). Participatory rural appraisal (PRA): Analysis of experience. World development, 22(9), 1253-1268.
- Gypmantasiri et al.,(1980) and Gordon Centre de International, Conway, Interdisciplinary An Perspective of Cropping Systems in the Chiang Moi Valley: Key Questions for Research (Thailand: Multiple-Cropping Project, Faculty of Agri- culture, University of Chiang Mai, June 1980).
- Loader, R., & Amartya, L. (1999). Participatory rural appraisal: extending the research methods base. Agricultural systems, 62(2), 73-85.
- Map, S. (1993). Participatory Rural Appraisal (PRA). [http://www.nirdpr.org.in/nird\\_docs/gpdp/prapra.pdf](http://www.nirdpr.org.in/nird_docs/gpdp/prapra.pdf) accessed on 24.04.2024.

- Mohammed, M.S., Shimelis, H.A., Laing, M.D. and Usman, A., (2023). Progress and opportunities on Bambara groundnut (*Vigna subterranea* [L.] Verdc.): genetic improvement and product development. In *Neglected and Underutilized Crops* (pp. 617-645). Academic Press.
- Paul, R. (2013). *Participatory Rural Appraisal (PRA) Manual*. FAO: Castries, Saint Lucia.
- Ravi K.N., Sontakki Bharat, S., Shimray Philanim Wungmarong., Mansuri Shekh Mukhtar., Verma Shilpi., Kiran Kumar, T. M., Gurjar Bholuram, Naik Vasudev. & Tegelli Raju. (2020). Field Experience Training: Pragmatic Multidisciplinary Approach for Developing Comprehensive Village Development Action Plan. *Indian Research Journal of Extension Education*. 20(1): 21-26.
- Sontakki, B., Venkatesan, P., & Rao, V. K. J. (2019). *Participatory Rural Appraisal (PRA): Tools & Techniques. A Training Manual for the IFS probationers* published by ICAR and ICAR-NAARM, Hyderabad.

## Livelihood Interventions for Landless and Skill Development for Youth in Watersheds

*Ravi Dupdal*

*Senior Scientist, ICAR-Indian Institute of Soil & Water Conservation,  
Research Centre, Ballari, Karnataka-583104*

### Introduction

The concept of Watershed as the planning unit for development of natural resources is effective and the watershed approach has gained significance since 1974 with various initiatives by the Government through DPAP, DDP, IWDP and NWDPPRA programmes. These programmes were basically adopted a 'Top-Down' approach which lacked participatory planning and in which importance to sectoral issues like agriculture, wasteland development, soil conservation was accorded priority thus they did not prove effective and successful. As a result, a need was felt to design a new Watershed Guidelines in 1995 with more thought on people's participation, a bottom-up approach at various levels of the project cycle, and also their integration with other employment generation and poverty alleviation programmes for generating more livelihood options for the focus groups. The recommendations of the Hanumantha Rao Committee, at least 75 per cent of the project amount was mandated to be spent on NRM-related activities. Following changes in the international and national policy atmosphere and governance agendas, non-NRM activities have again started gaining prominence. This has happened not through the trope of rural development but through tropes such as 'livelihoods', 'process focus' and 'participation,' and the emergences of 'the social' as an important site of governmental intervention. The MoRD revised the Common Guidelines in 2001 and then again in April 2003, which were then called the Hariyali Guidelines. Since the implementation of these changes, watershed development has become central to the process of governmental interventions in rural development with its focus on livelihoods and poverty alleviation. The watershed framework recognizes five capital assets where people can draw upon human, natural, financial, social and physical resources.

### Objectives of Watershed Development Programme

- ◆ The objectives of watershed development projects are to improve productive potential of rainfed/degraded land through integrated watershed management; to strengthen community based local institutions for promotion of livelihoods & watershed

sustainability, and to improve the efficiency of watershed projects through cross learning and incentive mechanism.

- ◆ Most watershed projects in India are implemented with the twin objectives of soil and water conservation and enhancing the livelihoods of the rural poor.
- ◆ Watershed development has been conceived basically as a strategy for protecting the livelihoods of the people inhabiting the fragile ecosystems experiencing soil erosion and moisture stress.
- ◆ One of the key features of the watershed development includes focused priority on livelihood activities for landless/asset less persons.
- ◆ At macro-level, the vision of WDC-PMKSY2.0 projects is to accelerate the economic growth rate of agriculture in the less endowed rainfed areas of the country. Moreover, this should be achieved by adopting harmony with ecological principles of development for ensuring sustained transformation of economy and ecology. The guiding principles shall be a better Economy, Ecology and Equity in the rainfed regions of the country.
- ◆ At watershed level, the development plan shall be guided by the need to achieve higher incomes for farmers, expanded livelihood options for landless, equity in distribution of benefits, community ownership and management, and ecologically sustainable action plan.

### Historical Changes in Approach to Watershed Development in India

| Pre-1994  | Post-1994   |
|---|---|
| <p>1. Sectoral approach: Each ministry/department had its own guidelines, programmes and per unit area fund allocations.</p> <ul style="list-style-type: none"> <li>❖ No coordination among ministries. Catchment treatment was undertaken in piecemeal manner.</li> </ul> <p>2. Centralized, top-down, command-and-control, regulatory approach: Management / control of natural resources entirely by government</p> <ul style="list-style-type: none"> <li>❖ Local Community's participation was limited to only providing cheap labour.</li> </ul> <p>3. No attention was paid to local community's needs and was Simply Technical Programmes: The interventions were highly mechanistic,</p> | <p>1. Holistic Ridge-To-Valley Integrated Approach (Watershed as a Unit for NRM):</p> <ul style="list-style-type: none"> <li>❖ Entire watershed i.e. all kinds of land - government, forest, community and private lands-that fall within a particular watershed are chosen for improvement and development.</li> <li>❖ Watershed development is more effective when done in an integrated and planned manner.</li> </ul> <p>2. People's Participation in Planning (Bottom-up Approach): People-centred approach, which recognizes that watershed development is impossible to undertake and sustain successfully</p> |

|   |  |
|---|--|
| <p>focusing primarily on technical engineering and plantation works.</p> <ul style="list-style-type: none"> <li>❖ No financial contribution from local communities.</li> <li>❖ Total lack of ownership of these programmes among local people.</li> </ul> | <p>without considering demands of local communities.</p> <p>3. People's Participation in Execution and Maintenance of a Watershed Development Programme (through collective action and contributions by benefiting communities): More sustainable natural resource management in the long run.</p> |
|---|--|

### Livelihood system in the watersheds

- A paradigm shift in the focus of mainstream watershed programme towards the marginalized and poor landless people
- It is an attempt to reverse the vicious cycle of poverty, assetlessness, vulnerability, debt and exclusion
- Primary objective of livelihood is to improve quality of life, food security, sanitation and health, literacy awareness, skill and income generating activities, Land based pisciculture, livestock, micro enterprise & micro finance etc.
- One of the key features of the watershed development includes focused priority on livelihood activities for landless/asset less persons.
- One of the aim of watershed is to creation of sustainable livelihood and enhancing income of household within watershed area.

### What is Livelihood?

Livelihood means support; subsistence, occupation or employment; means of living especially of earning enough money to feed the family and meets basic survival needs. Meaningfully occupied –Cope with risk and shocks –Sustainable –With dignity. It is mean of securing necessities of life. A livelihood is a means of making a living. It encompasses people's capabilities, assets, income and activities required to secure the necessities of life. A livelihood is sustainable when it enables people to cope with and recover from shocks and stresses (such as natural disasters and economic or social upheavals) and enhance their well-being and that of future generations without undermining the natural environment or resource base. Livelihood designates a set of activities involving securing water, food, fodder, medicine, shelter, clothing and the capacity to acquire above necessities working either individually or as a group by using endowments (both human and material) for meeting the requirements of the self and his/her household on a sustainable basis with dignity. According

to Chambers and Conway (1992) "a livelihood comprises the capabilities, assets and activities required for a means of living. A livelihood is sustainable when it can cope with and recover from stresses and shocks and maintain or enhance its capabilities and assets both now and in the future, while not undermining the natural resource base."

### Why Livelihood is Important?

- Nearly 60 percent of arable land in India is rainfed and depend on rainfall
- Rainfed area is characterized by low productivity, low income, low employment opportunities and incidence of poverty
- Management of natural resources at the watershed scale produce multiple benefits in terms of increasing food production, improving livelihood, protecting environment, addressing gender and equity issues along with biodiversity concerns.

### Principals of Livelihood

- **People-centred**: beginning by understanding peoples' priorities and livelihood strategies.
- **Responsive and participatory**: responding to the expressed priorities of poor people.
- **Multi-level**: ensuring micro-level realities inform macro-level institutions and processes.
- **Conducted in partnership**: working with public, private and civil society actors.
- **Sustainable**: environmentally, economically, institutionally, and socially. Dynamic: ensuring support is flexible and process-oriented, responding to changing livelihoods.
- **Holistic**: reflecting the integrated nature of people's lives and diverse strategies.
- **Building on strengths**: while addressing vulnerabilities

### Components of Livelihood

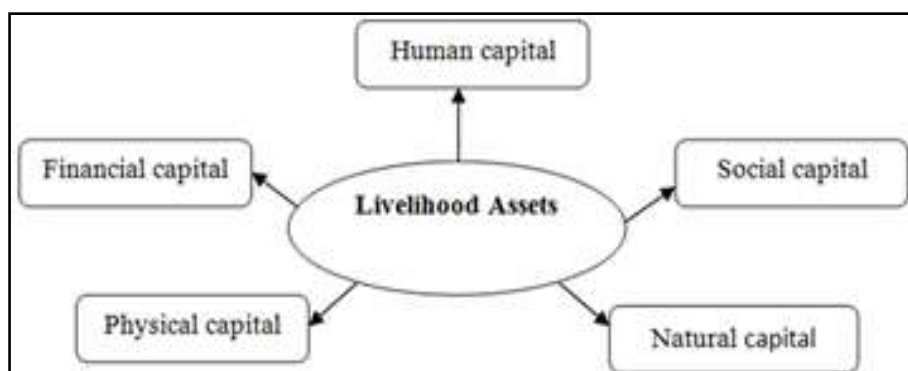

### Livelihood Approaches in the Watershed programme

- Enterprise at individual level
- Skill up gradation approaches



- Micro watershed approaches
- Cluster approaches/ Federation Convergence with other schemes and agencies

### **Guiding Principles of Livelihood Improvement in the Watershed**

The Integrated Watershed Management Project (IWMP) is being implemented in accordance with the Common Guidelines for Watershed Development Projects during 2008. One of the key features of the Common Guidelines includes focused priority on livelihood activities for landless/assetless persons. Nine percent of the total project cost has been assigned to support the livelihood activities for landless/assetless households and later it was increased to 15% under PMKSY-WDC. This component aims to maximize the utilization of potential generated by watershed activities and creation of sustainable livelihoods and enhanced incomes for households within the watershed area. This will facilitate inclusiveness through enhanced livelihood opportunities for the poor through investment into assets, improvements in productivity and income, and access of the poor to common resources and benefits and augment the livelihood strategy at household level.

Livelihood improvement initiatives should emphasize on natural resource based activities and must conform to principles of equity, gender sensitivity and transparency. It should strive to:

- Enhance livelihood opportunities for the poor through investment into asset creation and improvement in productivity and income.
- Improve access of the marginalized communities, including SC/ST, landless/assetless people, women, etc., to the benefits.
- Select the beneficiaries in a transparent manner.

Livelihood guidelines for landless/ assetless households should aim at improved household income, participation and division of labour, access to information, knowledge, appropriate technologies and resources.

### **Role of Self Help Groups (SHGs)**

The SHGs have proved successful across the country, particularly as centres of microcredit. Further, they have also taken up variety of livelihood activities in diverse fields. Promoting alternate livelihood activities being an important objective of a watershed project, conscious efforts should be made to make the existing SHGs as active partners in development strategy within the project area. While strengthening the existing ones, need based/resource based new ones may also be formulated. Effort may be made to federate all SHGs to improve business

opportunities. The WDT and WC should take this responsibility and create homogenous groups based on the common identity and interests of local people. The landless and weaker section members in particular will need to be mobilized. This initiative can be linked with the program of NABARD, MGNREGS, NRLM etc. The members of existing and new SHGs will need to be trained in different aspects of operations, credit management and livelihood activities.

### **Planning and Implementation**

The most important aspect in implementation of the guidelines would be the inclusion of 'micro level livelihood planning' as an empowerment tool for the marginalized communities. This planning will help in understanding the existing livelihood assets/capitals in a highly participatory manner to augment the existing livelihood platform.

### **Livelihood Planning in the watershed**

- The agency selected for implementing the watershed programmes will also be responsible to implement the livelihood component of IWMP.
- An awareness drive should be undertaken at Gram Sabha level for communication & sensitization of the target beneficiaries.
- A "Livelihood Action Plan" (LAP) will be a prerequisite for availing the funds under the livelihood component.
- The LAP should be prepared during the preparatory phase by the Project Implementing Agency (PIA) in consultation with WDT, WC and the members of SHGs, SC/ ST, women, landless/ assetless households. This plan should be an integral part of DPR. PIA may also take assistance of livelihood expert of the team/ agency specializing in livelihood sector who can be engaged on a time bound contract basis, expenditure on which may be incurred from Administrative component of the project. PIA should prepare livelihood action plan for the project area before the release of 2nd installment.
- To promote convergence, the PIA should work in close association with other employment generating programmes such as MGNREGS, NRLM, etc.
- The livelihood action plan should analyze socio-economic conditions and existing livelihood capitals of the watershed village during the situation analysis by means of PRA and focus group discussion in order to facilitate collection of information to feed into the livelihood action planning process. Livelihood action plan should contain schedule of activities, interventions, no. of SHGs to be assisted and expected outcome.

- A copy of the livelihood action plan should also be made available to concerned SHGs and Gram Panchayats. viii. The plan may be reviewed by the PIA, if need be, and revised in consultation with the stakeholders.

### **Mode of Operation of Livelihood Activities in the Watersheds**

- The livelihood action plan will be implemented through Self Help Groups and/or their federation. However financial support to enterprising individuals could also be considered subject to a maximum of 10% of the funds under the livelihood component.
- The Livelihood activities can be carried out either through the existing SHGs having good performance or new SHGs formed with a group of 5-20 persons.
- SHGs selected for implementing livelihood action plan should be homogeneous in terms of their existing livelihood capitals, common interest and need.
- SHGs can undertake any permissible activity jointly as a group or the group may decide to support individual(s) for the activities under the umbrella of the main SHG. In case of individual support under the SHGs, the individuals will be accountable to the main SHG for finances and performance.
- The financial support to enterprising individuals who prepare and submit a viable livelihood proposal, may be considered by Watershed Cell cum Data Centre (WCDC) on the recommendation of the Watershed Committee (WC). The plan has to be approved by the WCDC before extending financial support. However, support to individuals should not exceed a maximum of 10% of funds under the livelihood component.

### **Eligibility for Availing the Funds for Livelihood Components**

The beneficiaries should be marginalized communities, including SC/ST, landless/assetless people, women, etc., among which preference will be given to women, specially female headed households, ST & SCs, as identified under the wealth ranking conducted as a part of the PRA exercise. It may be ensured that the selected SHG does not have more than one member from a household and priority may be given to women SHGs.

### **Capacity Building and Skill Development for Beneficiaries in the Watersheds**

- The capacity building needs of the marginalized communities, including SC/ST, landless/assetless people, women, etc should be included in the livelihood action plan

prepared after the livelihood analysis. The capacity building should aim at skill enhancement and not just knowledge and information. The capacity building component should be planned by the livelihood expert of WDT/Livelihood agency in consultation with WC for making necessary budgetary provision on annual basis.

- The expenditure for the training for livelihood component may be met from 5% of the budget component of the project cost earmarked for institution and capacity building.
- It shall be mandatory to provide skill based training on the following components apart from the other training needs expressed by SHGs: a. Book Keeping (cash book and ledger registers, preparing budget, maintenance of accounts etc). b. Minutes of meeting (proceedings) and follow up. c. Exposure visits and discussions in the specialized areas of livestock, agriculture/horticulture, agro-forestry, fisheries and other watershed related income generating activities, micro-enterprises, micro-credit, etc. d. Knowledge of market and pricing, value addition, alternate institutions including Farmers Production Companies etc. e. Other related aspects.

### Budget provisions in the Watershed

The major head-wise distribution of budget for a specific watershed project will be as in the Table below:

| Major Head                       | Sub Heads  | Percentage of Budget |
|----------------------------------|--|----------------------|
| Administrative                   | Management Cost Monitoring & Evaluation  | 10                   |
|                                  | Management Cost Monitoring & Evaluation  | 2                    |
| Preparatory Phase                | Entry Point Activity   | 2                    |
|                                  | DPR Preparation  | 1                    |
|                                  | Institution & Capacity Building  | 3                    |
| Works Phase                      | Natural Resource Management  | 47                   |
|                                  | Production System  | 15                   |
|                                  | Natural Resource Management & Governance   | 2                    |
|                                  | Livelihood Activities for the asset less persons, Micro Enterprises & Business Development | 15                   |
| Consolidation & Withdrawal Phase |  | 3                    |
| <b>Total</b>                     |  | <b>100</b>           |

(Source: New generation Watershed Guidelines, DoLR and NRAA, 2021)

### Different Livelihood Activities enlisted in the Watershed

- Small entrepreneur system – Tailoring, carpet making, Kirana shops, bakery unit and soap making etc.

- Household production system – Pickle and sauce making units
- Biomass based rural industry – Honey and mushroom production
- Dairy activities – cow rearing
- Livestock management – Goat and backyard rearing
- Organic farming - Vermicomposting
- Agri-horti collection centre – floriculture
- Processing units – fruits and vegetables

### Some success stories and case studies from model watersheds

1. **Netranahalli Watershed:** Watershed was located at Molkaluru taluka of Chitradurga district with Latitude: 14° 37' 50" to 14° 38' 47" N Longitude: 76° 42' 46" to 76° 44' 51" E and situated AER at Eastern Ghats and Tamil Nadu Uplands and Deccan with area of about 480 ha implemented by ICAR-IISWC, RC Ballari during 2008-09-2014-15 with financial support of MoRD, Government of India.

**Box 1 :Livelihood interventions and activities taken under the watershed:**

- ❖ **Income generating activities for landless and marginal farmers:** Establishment of vermi-compost units (25) with 3 m x 2 m dimension pits constructed using locally available materials .
- ❖ **Beekeeping:** 35 live colonies of honey bee were distributed to the landless farmers for enhancing crop productivity and also as secondary source of income to the farmers
- ❖ **Animal Health Camp**
- ❖ **Pisciculture:** Fish fingerlings of Rohu, Catla, and Common Carp etc) were obtained from the state fisheries department and introduced in 11 ponds of willing farmers.
- ❖ **Training, extension and capacity building programmes**

2. **Ramasagara Watershed:** Watershed was located at Molkaluru taluka of Chitradurga district with Latitude: 14°49'31" to 14°50'42" N Longitude: 76°47'32" to 76°47'32" E and situated AER at 3-Hot Arid Eco-region with Red and Black soils with area of about 480.37ha implemented by ICAR-IISWC, RC Ballari during 2008-09-2013-14 with financial support of Ministry of Agriculture under the scheme National Watershed Development Project for Rainfed Areas (NWDPA).

**Box 2:Livelihood interventions and activities taken under the watershed:**

- ❖ **Distribution of vegetable seeds for kitchen garden** for landless and marginal farmers
- ❖ **Construction of vermicompost units** for improving soil fertility and enriching the nutrient status of the soil
- ❖ **Distribution of livestock and small ruminants-** Cow, sheep, goat and backyard poultries for livelihood enhancement
- ❖ **Micro-enterprises interventions:** Tailoring machines, specialized barber kits, artisan tools (blacksmithy and carpentry were distributed etc
- ❖ **Animal Health Camps**
- ❖ **Training and capacity building programmes**

## Conclusion

The main objective of watershed management is to implant the sustainable management of natural resources to improve the quality of living for the population and twin objectives of watershed development in India are soil and water conservation and enhancing the livelihood of rural poor. Holistic development of watershed encompasses sustainable livelihood opportunities and efficient utilization of existing resources and it is conceived basically as a strategy for protecting the livelihoods of the people inhabiting the fragile ecosystems experiencing soil erosion and moisture stress.

## References

- Adhikari, R.N.; Patil, A.; Raizada, D.; Ramajayam, M.; Prabhavathi, N.; Mondal, B.; Mishra, P.K. *Participatory Resource Conservation and Management in Semi-arid India—A Case Study from Netranahalli Watershed (Karnataka)*; Technical Bulletin; Central Soil & Water Conservation Research & Training Institute, Research Centre: Bellary, Karnataka, India, 2013; p. 65
- Chambers, R. and Conway, G, 1992. Sustainable Rural Livelihoods: Practical Concepts for the 21st Century, Institute of Development Studies Discussion Papers, 296. Cambridge. 11p.
- MoRD, Government of India 2011. Operational Guidelines for ‘Livelihood for landless/ assetless’ and ‘Production system & Microenterprises’ components of IWMP.11p.
- MoRD, Government of India 2021. Guidelines for New Generation Watershed Development Projects (Wdc-Pmksy 2.0). 91p.
- Patil, S.L., R.N. Adhikari, A. Raizada, D. Ramajayam, M.N. Ramesha, K.K. Reddy, M. Prabhavathi, N. Loganandhan, S.K.N. Math and K. Channabasappa. 2020. Conservation and Management of Natural Resources in Ramasagara Watershed, Molakalmuru Taluk, Chitradurga District, Karnataka, India., ICAR-Indian Institute of Soil & Water Conservation, Research Centre, Ballari, Karnataka, India, 100p.
- Routray, S. and Shantha Mohan N., 2012. Securing Livelihoods: The Watershed Plus Approach and Emergence of ‘The Social’ in a Watershed Project in Odisha. *Indian Journal of Human Development*, 6(2): 267-281.



# Watershed-Based Natural Resource Management for Drought Proofing



**ICAR-Indian Institute of Soil and Water Conservation (IISWC), Research Centre,  
Ballari -583 104 (Karnataka)**

**&**

**National Institute for Agricultural Extension Management (MANAGE), Hyderabad,  
Telangana**